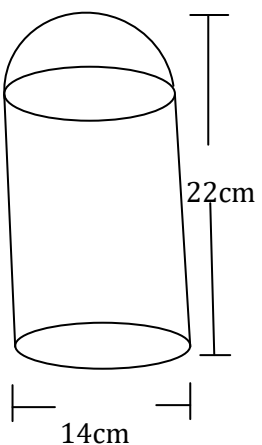

NAME \_\_\_\_\_ INDEX NUMBER \_\_\_\_\_

SCHOOL \_\_\_\_\_ DATE \_\_\_\_\_

## MEASUREMENT

<i>KCSE 1989 – 2012 Form 1 Mathematics</i>		Working Space
1.	<p><b>1989 Q9 P1</b></p> <p>The base of an open rectangular tank is 3.2m by 2.8m. Its height is 2.4m. It contains water to a depth of 1.8m. Calculate the surface area of inside the tank that is not in contact with water. (2 marks)</p>	
2	<p><b>1989 Q16 P2</b></p> <p>The solid shown in the figure below consists of a cylinder and a hemisphere of equal diameters of 14cm. If the height of the solid is 22cm, find its volume.</p>  <p>(4 marks)</p>	

3

**1990 Q9 P1**

The figure below shows a sector of a circle. If the area of the sector is  $30.8\text{cm}^2$ , calculate the length of the arc AB.  
(Take  $\pi$  to be  $\frac{22}{7}$ ) (3 marks)

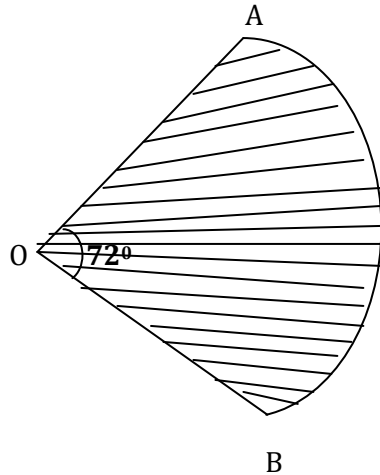

4

**1990 Q11 P1**

The figure below shows a vertical section of a hemispherical pot centre O. The radius OA of the pot is 20cm. If the pot contains water to a depth of 8cm, calculate the diameter of the water surface. (3 marks)

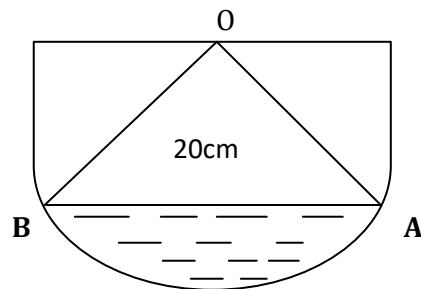

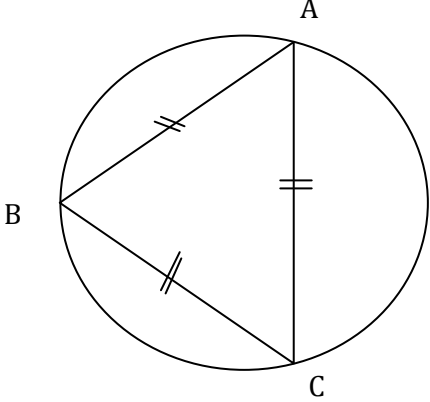
		Working Space
5	<p><b>1990 Q14 P1</b></p> <p>The figure below shows an equilateral triangle ABC inscribed in a circle of radius 6cm. Calculate the length of the side of the triangle. (2 marks)</p> 	
6	<p><b>1990 Q13 P2</b></p> <p>A metal bar 14cm long and 5cm in diameter is melted down and cast into circular washers. Each washer has an external diameter of 4cm and an internal diameter of <math>1\frac{1}{2}</math>cm and is 0.3cm thick. Calculate the number of complete washers obtained. (Take <math>\pi \approx \frac{22}{7}</math>) (4 marks)</p>	
7	<p><b>1991 Q12 P1</b></p> <p>A cone of radius 20cm has a slant height of 52cm. A frustum is cut off from this cone such that its top is 10cm and its slant height is 26cm (see diagram below). Calculate the area of the curved surface of the frustum. (3 marks)</p>	

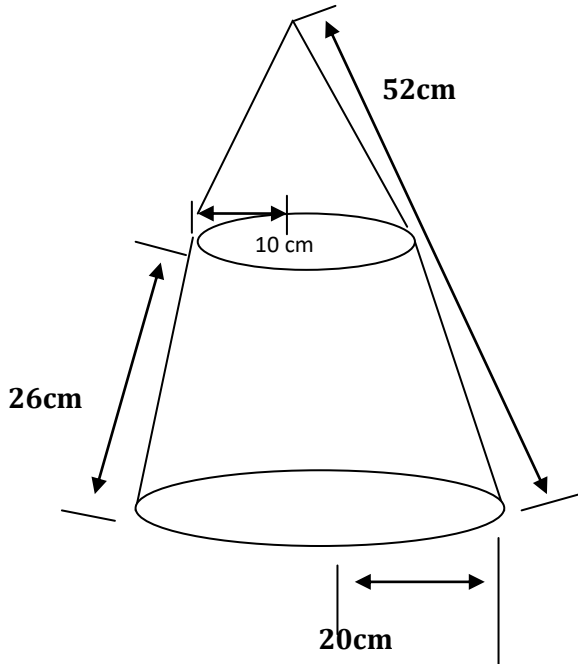

8

**1991 Q17 P2**

The metal solid shown in the figure below is made up by joining a hemisphere of radius 7cm to a cylinder of the same radius. The mass and density of the solid are 40kg and 17.5gm per cm<sup>3</sup>, respectively. Calculate the height of the cylindrical part of the solid. (8marks)

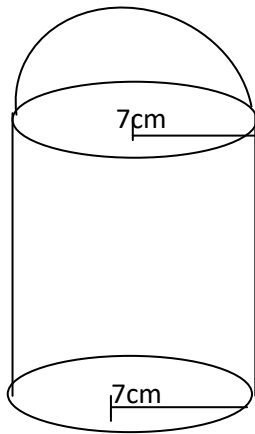

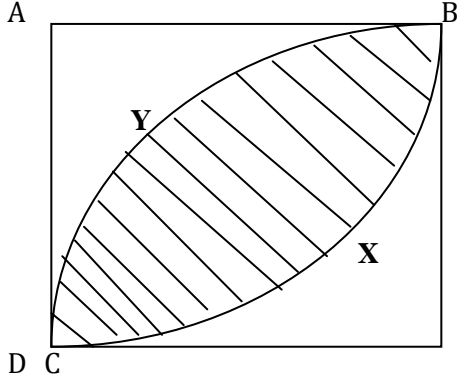
		Working Space
9	<p><b>1992 Q4 P1</b>            The two diagonals of a parallelogram are 20cm and 28.8cm. The acute angle between them is <math>62^\circ</math>. Calculate the area of the parallelogram. (3 marks)</p>	
10	<p><b>1992 Q15 P1</b>            In the figure below, ABCD is a square of side 4cm. BYD are arcs of circles centres A and C respectively. Calculate the area of the shaded region. (Take <math>\pi</math> 3.14)</p>  <p style="text-align: right;">(4marks)</p>	
11	<p><b>1992 Q17 P1</b>            A room is to be constructed such that its external length and breadth are 7.5m and 5.3m respectively. The thickness of the wall is 15cm, and its height is 3.3cm. A total space of <math>5\text{m}^3</math> is to be left out in the walls for a door and windows.</p> <p>(a) Calculate the volume of the material needed to construct the walls without the door and the windows. (4marks)</p> <p>(b) The block used in constructing the walls are 45 cm x 20cm x 15 cm. 0.225<math>\text{m}^3</math> of cement mixture is used to join the blocks. Calculate the number of blocks needed to construct the room. (4marks)</p>	

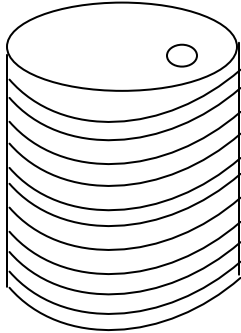
		Working Space
12	<p><b>1992 Q22 P1</b></p> <p>The diagram below shows a model of a cylindrical water tank. The total surface area of the model is <math>0.4\text{m}^2</math> and the surface area of the actual tank is <math>14.4\text{m}^2</math>.</p> <p>(i) If the height of the tank is 2.1m, find the height of the model. (4marks)</p> <p>ii) If the capacity of the model is 23.15litres, find the capacity of the tank to the nearest litre. (4marks)</p> 	
13	<p><b>1992 Q20 P2</b></p> <p>A swimming pool 30m long is 1m deep at its shallow end 4m deep at its deep end. The pool is 14m wide.</p> <p>(a) Find the volume of water, in cubic metres, when the pool is full. (4marks)</p> <p>(b) A circular pipe of diameter 14cm is used to empty the swimming pool. Water flows through pipe at a rate of 5m per sec.</p> <p>Calculate the time it would take, to the nearest minute, to empty the pool. (4marks)</p>	

14 **1993 Q7 P1**

The figure alongside shows the cross-section of a metal bar of length 40mm. The ends are equal semi-circles.

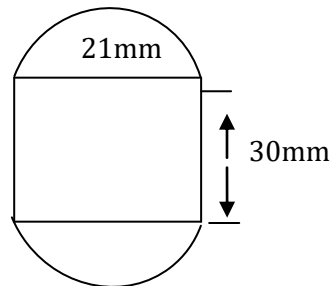

Determine its mass if the density of the metal is  $8.8 \text{ g/cm}^3$  (Take  $\pi = \frac{22}{7}$ )

15 **1993 Q15 P1**

A rostrum is made by cutting off the upper part of a cone along a plane parallel to the base at  $\frac{2}{3}$  up the height. What fraction the volume of the cone does the rostrum represent?

16 **1993 Q9 P2**

A plug is made up of a hemi-spherical cap of radius 4.2cm, and a cylinder of diameter 3.5cm and height 5.0cm as shown in the diagram alongside. Calculate the volume of the plug. (3marks)

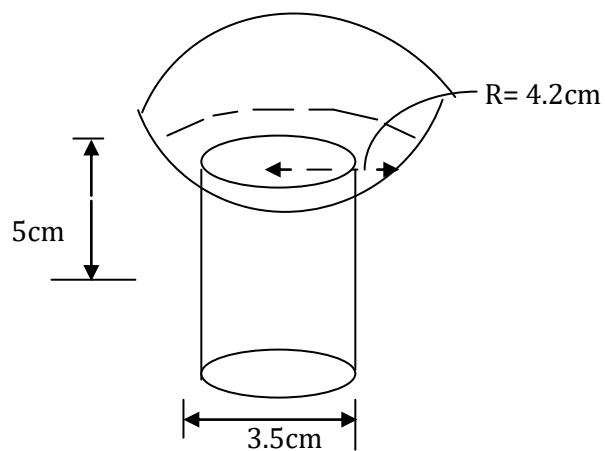

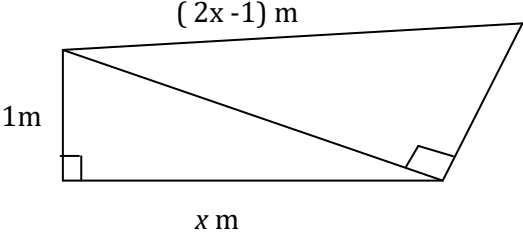
		Working Space
17	<p><b>1995 Q 4 P2</b></p> <p>Calculate volume of a prism whose length is 25cm and whose cross- section is an equilateral triangles of 3 cm</p>	
18	<p><b>1995 Q 9 P2</b></p> <p>A boat moves 27 km/h in still water. It is to move from point A to a point B which is directly east of A. If the river flows from south to North at 9 km/ h, calculate the track of the boat</p>	
19	<p><b>1995 Q 14 P2</b></p> <p>Two containers, one cylindrical and one spherical, have the same volume. The height of the cylindrical container is 50 cm and its radius is 11 cm. Find the radius of the spherical container. (2 marks)</p>	
20	<p><b>1996 Q 7 P2</b></p> <p>In the figure below BAD and CBD are right angled triangles.</p>  <p>Find the length of AB (4 marks)</p>	



		Working Space
21	<p><b>1997 Q 6 P1</b></p> <p>A cylinder of radius 14 cm contains water. A metal solid cone of base radius 7 cm and height 18cm is submerged into the water. Find the change in height of the water level in the cylinder.</p>	
22	<p><b>1997 Q 16 P2</b></p> <p>A metal bar is a hexagonal prism whose length is 30 cm. The cross – section is a regular hexagon with each side of the length 6 cm.</p> <p>Find</p> <p>(i) the area of the hexagonal face</p> <p>(ii) the volume of the metal bar</p>	
23	<p><b>1998 Q 11 P1</b></p> <p>A cylindrical container of radius 15cm has some water in it. When a solid is submerged into the water, the water level rises by 1.2 cm.</p> <p>(a) Find, the volume of the water displaced by the solid leaving your answer in terms of <math>\pi</math></p> <p>(b) If the solid is a circular cone of height 9 cm, calculate the radius of the cone to 2 decimal places.</p>	

		Working Space
24	<p><b>1998 Q 21 P1</b></p> <p>A cylindrical can has a hemisphere cap. The cylinder and the hemisphere are of radius 3.5 cm. The cylindrical part is 20 cm tall. Take <math>\pi</math> to be <math>\frac{22}{7}</math></p> <p>Calculate</p> <ul style="list-style-type: none"> <li>(a) the area of the circular base</li> <li>(b) the area of the curved cylindrical surface</li> <li>(c) the area of the curved hemisphere surface</li> <li>(d) The total surface area.</li> </ul>	
25	<p><b>1998 Q 11 P2</b></p> <p>A balloon, in the form of a sphere of radius 2 cm, is blown up so that the volume increase by 237.5%.</p> <p>Determine the new volume of balloon in terms of <math>\pi</math></p>	
26	<p><b>1999 Q4 P1</b></p> <p>An open right circular cone has a base radius of 5 cm and a perpendicular height of 12 cm. Calculate the surface area of the cone.(Take <math>\pi = 3.14</math>)</p>	

27 **1999 Q 8 P1**

A girl wanted to make a rectangular octagon of side 14cm. She made it from a square piece of a card of size  $y$  cm by cutting off four isosceles triangles whose equal sides were  $x$  cm each, as shown below.

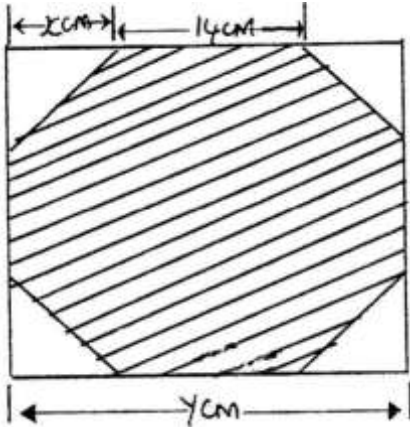

- Write down an expression for the octagon in terms of  $x$  and  $y$
- Find the value of  $x$
- Find the area of the octagon

28 **1999 Q 13 P1**

An artisan has 63 kg of metal of density  $7,000\text{kg/m}^3$ . He intends to use to make a rectangular pipe with external dimensions 12 cm by 15 cm and internal dimensions 10 cm by 12 cm. Calculate the length of the pipe in metres

29 **1999 Q 23 P1**

The diagram below shows a cross-section of a bottle. The lower part ABC is a hemisphere of radius 5.2 cm and the upper part is a frustrum of a cone. The top radius of the frustrum is one third of the radius of the hemisphere. The hemisphere part is completely filled with water as shown in the diagram.

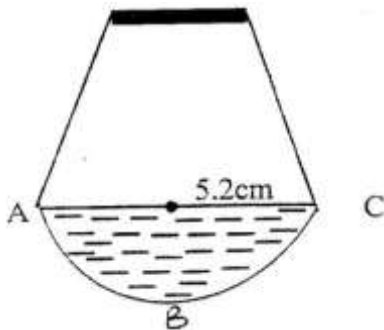

When the container is inverted, the water now completely fills only the frustrum part.

- Determine the height of the frustrum part
- Find the surface area of the frustrum part of the bottle.

30 **2000 Q 9 P1**

The figure below shows an octagon obtained by cutting off four congruent triangles from rectangle measuring 19.5 by 16.5 cm

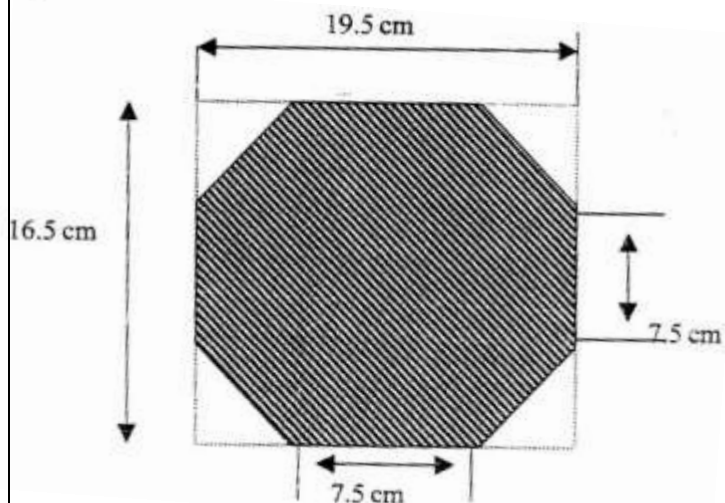

Calculate the area of the octagon

31 **2000 Q 20 P1**

A solid made up of a conical frustrum and a hemisphere top as shown in the figure below. The dimensions are as indicated in the figure.

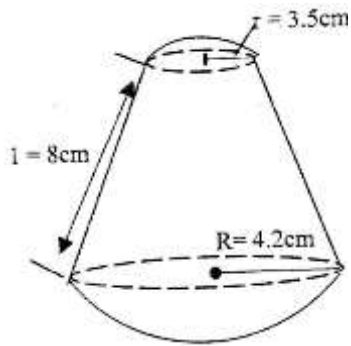

- (a) Find the area of
- The circular base
  - The curved surface of the frustrum
  - The hemisphere surface
- (b) A similar solid has a total area of  $81.51 \text{ cm}^2$ . Determine the radius of its base.

32 **2000 Q 3 P2**

Two sides of a triangle are 5 cm each and the angle between them is  $120^\circ$ . Calculate the area of the triangle.

33 **2000 Q 4 P2**

A piece of wire  $P$  cm long is bent to form the shape shown in the figure below

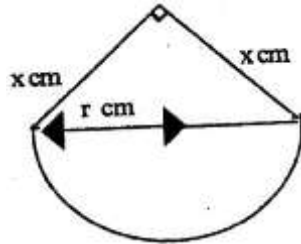

The figure consists of a semicircular arc of radius  $r$  cm and two perpendicular sides of length  $x$  cm each.

Express  $x$  in terms of  $P$  and  $r$ ,

Hence show that the area  $A$  cm<sup>2</sup>, of the figure is given by  $A = \frac{1}{2} \pi r^2 + \frac{1}{8} (p - \pi r)^2$

34 **2001 Q 2 P1**

The figure below represents a kite  $ABCD$ ,  $AB = AD = 15$  cm. The diagonals  $BD$  and  $AC$  intersect at  $O$ .  $AC = 30$  cm and  $AO = 12$  cm.

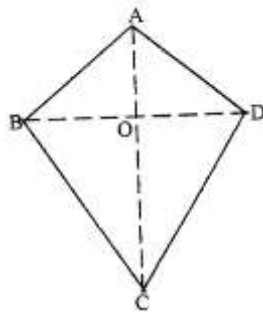

Find the area of the kite

35 **2001 Q 4 P1**

The diagram below represents a solid made up of a hemisphere mounted on a cone. The radius of the cone and the radius of the hemisphere are each 6 cm and the height of the cone is 9 cm.

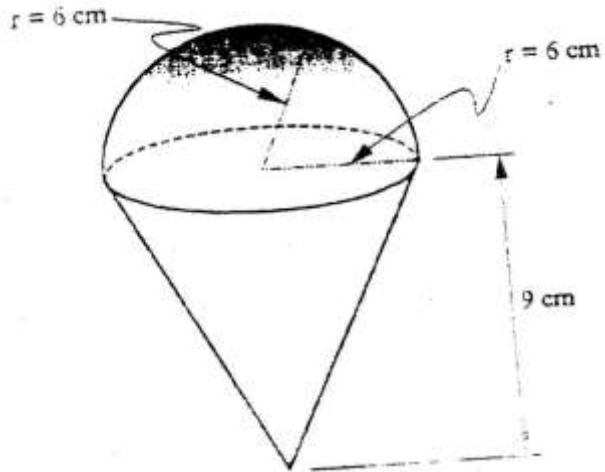

Calculate the volume of the solid. Take  $\pi$  as  $\frac{22}{7}$   
(3 marks)

36 **2001 Q 12 P2**

The figure represents a pentagon prism of length 12 cm. The cross-section is a regular pentagon, centre O, whose dimensions are shown.

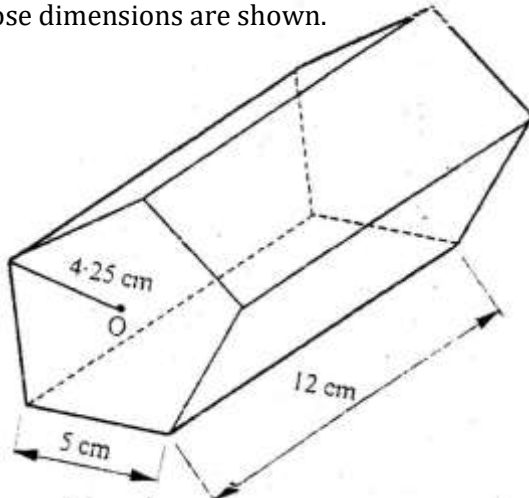

Find the total surface area of the prism.

37 **2001 Q 23 P2**

The diagram below represents a pillar made of Cylindrical and regular hexagonal parts. The diameter and height of the cylindrical part are 1.4m and 1m respectively. The side of the regular hexagonal face is 0.4m and height of hexagonal part is 4m.

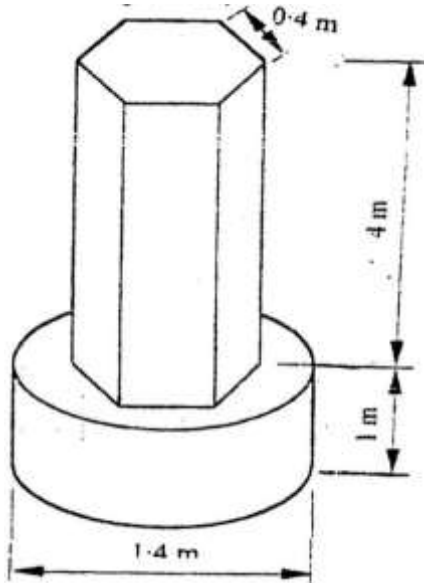

- a) Calculate the volume of the :
- Cylindrical part
  - Hexagonal part
- b) An identical pillar is to be built but with a hollow centre cross - section area of  $0.25\text{m}^2$ . The density of the material to be used to make the pillar is  $2.4\text{g}/\text{cm}^3$ . Calculate the mass of the new pillar.



38 **2002 Q 6 P1**

The figure below is a polygon in which  $AB = CD = FA = 12\text{cm}$   $BC = EF = 4\text{cm}$  and  $\angle BAF = \angle CDE = 120^\circ$ .  $AD$  is a line of symmetry.

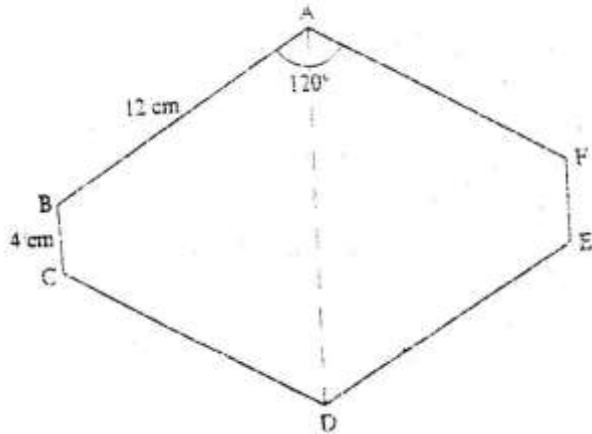

Find the area of the polygon.

39 **2002 Q 11 P1**

The internal and external diameters of a circular ring are  $6\text{cm}$  and  $8\text{cm}$  respectively. Find the volume of the ring if its thickness is  $2\text{ millimeters}$ . (3marks)

40 **2002 Q 3 P2**

A triangular flower garden has an area of  $28\text{m}^2$ . Two of its edges are  $14\text{ metres}$  and  $8\text{ metres}$ . Find the angle between the two edges.

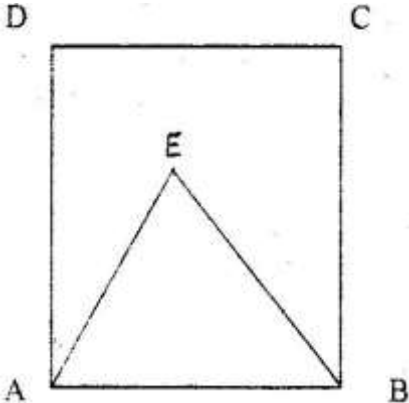
		Working Space
41	<p><b>2003 Q 10 P1</b></p> <p>The length of a solid prism is 10cm. Its cross section is an equilateral triangle of side 6cm. Find the total surface area of the prism.</p>	
42	<p><b>2003 Q 11 P1</b></p> <p>A wire of length 21cm is bent to form the shape down in the figure below, ABCD is a rectangle and AEB is an equilateral triangle. (2marks)</p>  <p>If the length of AD of the rectangle is <math>1\frac{1}{2}</math> times its width, calculate the width of the rectangle.</p>	
43	<p><b>2003 Q 13 P1</b></p> <p>The length of a hollow cylindrical pipe is 6metres. Its external diameter is 11cm and has a thickness of 1cm. Calculate the volume in <math>\text{cm}^3</math> of the material used to make the pipe. Take <math>\pi</math> as 3.142.</p>	

		Working Space
44	<p><b>2003 Q 17 P1</b></p> <p>A rectangular tank whose internal dimensions are 1.7m by 1.4m by 2.2m is three – quarters full of milk.</p> <p>a) Calculate the volume of milk in the tank in cubic metres.</p> <p>b) The milk is to be packed in small packets. Each packet is in the shape of a right pyramid on an equilateral triangular base of side 16cm. The height of each packet is 13.6cm. Full packets obtained are sold at sh.25 per packet. Calculate</p> <p>i) The volume of milk in cubic centimeters, contained in each packet to 2 significant figures (4 marks)</p> <p>ii) The exact amount that will be realized from the sale of all the packets of milk. (2 marks)</p>	
45	<p><b>2003 Q 9 P2</b></p> <p>The surface area of a solid hemisphere is radius <math>r</math> cm is <math>75\pi</math> cm<sup>2</sup>. Find the volume of the solid, leaving your Answer in terms of <math>\pi</math> (4 marks)</p>	

46 **2004 Q 13 P1**

The figure below represents a hexagon of side 5cm.

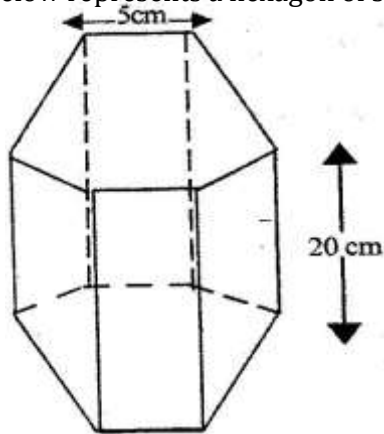

Find the volume of the prism.

47 **2004 Q 19 P1**

The figure below represents a model of a solid structure in the shape of a frustum of a cone with hemispherical top.

The diameter of the hemispherical part is 70cm and is equal to the diameter of the top of the frustum. The frustum has a base diameter of 28cm and slant height of 60cm.

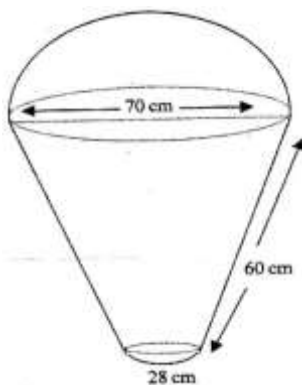

Calculate

- The area of hemispherical surface.
- The total surface area of the model.

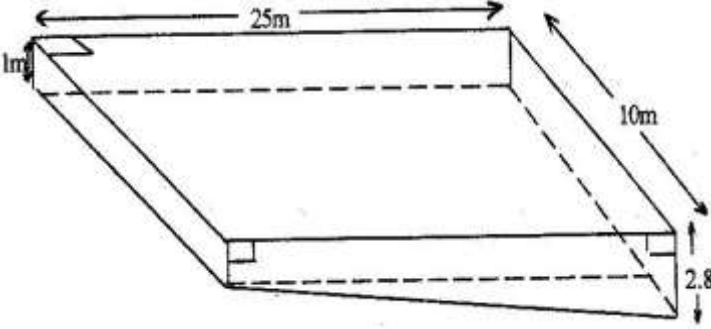
		Working Space
48	<p><b>2005 Q 3 P1</b>            The area of a rhombus is <math>60\text{cm}^2</math>. Given that one of its diagonals is <math>15\text{ cm}</math> long, Calculate the perimeter of the rhombus            (3 marks)</p>	
49	<p><b>2005 Q 12 P1</b>            A cylindrical piece of wood of radius <math>4.2\text{ cm}</math> and length <math>150\text{ cm}</math> is cut length into two equal pieces. Calculate the surface area of one piece            (Take <math>\pi</math> as <math>\frac{22}{7}</math>)            (4marks)</p>	
50	<p><b>2005 Q 19 P1</b>            The diagram below represents a rectangular swimming pool <math>25\text{m}</math> long and <math>10\text{m}</math> wide. The sides of the pool are vertical.</p>  <p>The floor of the pool slants uniformly such that the depth at the shallow end is <math>1\text{m}</math> at the deep end is <math>2.8\text{ m}</math>.</p> <p>(a) Calculate the volume of water required to completely fill the pool.</p>	

b) Water is allowed into the empty pool at a constant rate through an inlet pipe. It takes 9 hours for the water to just cover the entire floor of the pool.

Calculate:

- (i) The volume of the water that just covers the floor of the pool (2 marks)
- (ii) The time needed to completely fill the remaining of the pool. (3 marks)

51 **2006 Q 19 P1**

The diagram below ( not drawn to scale) represents the cross- section of a solid prism of height 8.0 cm

(3 marks)

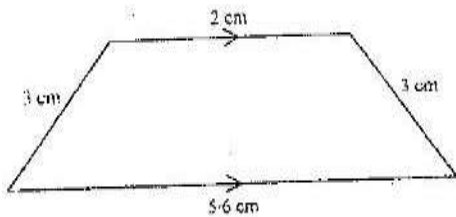

(a) Calculate the volume of the prism (3 marks)

(b) Given that the density of the prism is  $5.75\text{g/cm}^3$ , calculate its mass in grams (2 marks)

(c) A second prism is similar to first one but is made of a different materials. The volume of the second is  $246.24\text{cm}^3$

(i) calculate the area of the cross section of the second prism (3 marks)

(ii) Given that the ratio of the mass of the first to that of the second is 2: 5 and the density of the second prism (2 marks)

52 **2006 Q 23 P1**

The figure below is a model representing a storage container. The model whose total height is 15cm is made up of a conical top, a hemispherical bottom and the middle part is cylindrical. The radius of the base of the cone and that of the hemisphere are each 3cm. The height of the cylindrical part is 8cm.

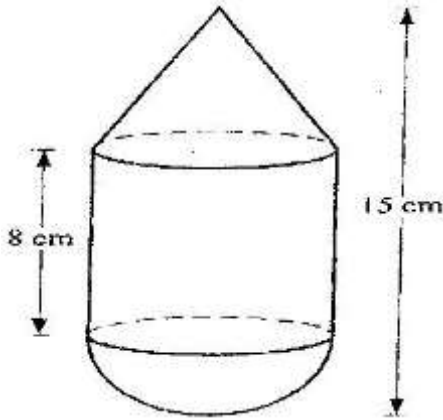

- (a) Calculate the external surface area of the model  
(4 marks)
- (b) The actual storage container has a total height of 6 metres. The outside of the actual storage container is to be painted. Calculate the amount of paint required if an area of  $20\text{m}^2$  requires 0.75 litres of the paint  
(6 marks)

53 **2007 Q 7 P1**

A square brass plate is 2 mm thick and has a mass of 1.05 kg. The density of the brass is  $8.4\text{ g/cm}^3$ . Calculate the length of the plate in centimeters  
(3 marks)

54 **2007 Q 9 P1**

A cylindrical solid of radius 5 cm and length 12 cm floats lengthwise in water to a depth of 2.5 cm as shown in the figure below.

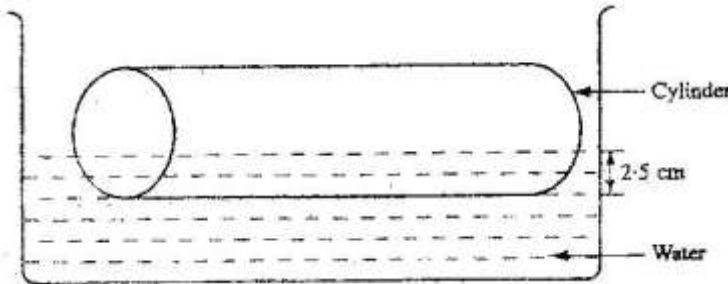

Calculate the area of the curved surface of the solid in contact with water, correct to 4 significant figures  
(4 marks)

55 **2007 Q 22 P1**

Two cylindrical containers are similar. The larger one has internal cross-section area of  $45\text{cm}^2$  and can hold 0.945 litres of liquid when full. The smaller container has internal cross-section area of  $20\text{cm}^2$

(a) Calculate the capacity of the smaller container

(b) The larger container is filled with juice to a height of 13 cm. Juice is then drawn from it and emptied into the smaller container until the depths of the juice in both containers are equal. Calculate the depths of juice in each container (2marks)

(c) On fifth of the juice in the larger container in part (d) above is further drawn and emptied into the smaller container. Find the difference in the depths of the juice in the two containers. (4 marks)



		Working Space
56	<p><b>2008 Q 4 P1</b></p> <p>Mapesa traveled by train from Butere to Nairobi. The train left Butere on a Sunday at 23 50 hours and traveled for 7 hours 15 minutes to reach Nakuru. After a 45 minutes stop in Nakuru, the train took 5 hours 40 minutes to reach Nairobi.</p> <p>Find the time, in the 12 hours clock system and the day Mapesa arrived in Nairobi.</p> <p style="text-align: right;">(2 marks)</p>	
57	<p><b>2008 Q 7 P1</b></p> <p>A liquid spray of mass 384g is packed in a cylindrical container of internal radius 3.2cm. Given that the density of the liquid is <math>0.6\text{g/cm}^3</math>, calculate to 2 decimal places the height of the liquid in the container.</p> <p style="text-align: right;">(3 marks)</p>	
58	<p><b>2008 Q 9 P1</b></p> <p>A solid metal sphere of radius 4.2 cm was melted and the molten material used to make a cube. Find to 3 significant figures the length of the side of the cube.</p>	

59 **2008 Q 13 P1**  
 A rectangular and two circular cut-outs of metal sheet of negligible thickness are used to make a closed cylinder. The rectangular cut-out has a height of 18cm. Each circular cut-out has a radius of 5.2cm. Calculate in terms of  $\pi$ , the surface area of the cylinder  
 (3 marks)

60 **2008 Q 22 P1**  
 The diagram below represents a conical vessel which stands vertically. The vessel contains water to a depth of 30cm. The radius of the surface in the vessel is 21cm. (Take  $\pi = \frac{22}{7}$ ).

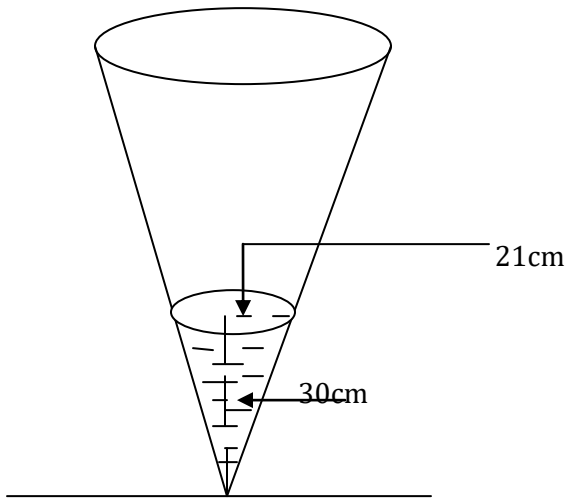

a) Calculate the volume of the water in the vessels in  $\text{cm}^3$

b) When a metal sphere is completely submerged in the water, the level of the water in the vessels rises by 6cm. Calculate:

- (i) The radius of the new water surface in the vessel; (2 marks)
- (ii) The volume of the metal sphere in  $\text{cm}^3$  (3 marks)
- (iii) The radius of the sphere. (3 marks)

61 **2009 Q 6 P1**

The figure below represents a plot of land ABCD such that  $AB = 85\text{ m}$ ,  $BC = 75\text{ m}$ ,  $CD = 60\text{ m}$ ,  $DA = 50\text{ m}$  and  $\text{Angle } ACB = 90^\circ$

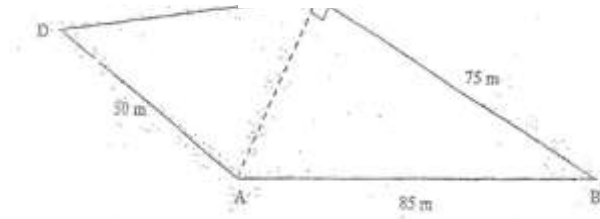

Determine the area of the plot in hectares correct to two decimal places (4 marks)

62 **2009 Q 7 P1**

A watch which loses a half minutes every hour was set to reach the correct time at 05 45h on Monday. Determine the time in the 12 hour system, the watch will show on the following Friday at 1945h. (3 marks)

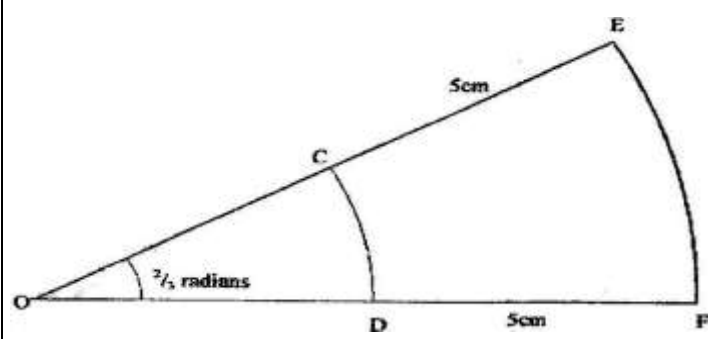
		Working Space
63	<p><b>2010 Q 14 P1</b>            A cylindrical solid whose radius and height are equal has a surface area of <math>154 \text{ cm}^2</math>.            Calculate its diameter, correct to 2 decimal places.            (Take <math>\pi = 3.142</math>). (3 marks)</p>	
64	<p><b>2010 Q 15 P1</b>            The figure below shows two sectors in which CD and EF are arcs of concentric circles, centre O. Angle COD = 2 radians and CE = DF = 5 cm.</p>  <p>If the perimeter of the shape CDFE is 24 cm, calculate the length of OC.</p>	

		Working Space
65	<p><b>2010 Q 18 P1</b>  A carpenter constructed a closed wooden box with internal measurements 1.5 metres long, 0.8 metres wide and 0.4 metres high. The wood used in constructing the box was 10 cm thick and had a density of 0.6 g/cm<sup>3</sup>.</p> <p>a). Determine the:</p> <p>(i) Volume in cm<sup>3</sup>, of the wood used in constructing the box (4 marks)</p> <p>(ii) Mass of the box in kilograms, correct to 1 decimal place. (2 marks)</p> <p>b). Identical cylindrical tins of diameter 10 cm, height 20 cm with a mass of 120 g each were packed in the box.  Calculate the:</p> <p>(i) Maximum number of tins that were packed. (2 marks)</p> <p>(ii) Total mass of the box with the tins. (2 marks)</p>	
66	<p><b>2011 Q 2 P1</b>  The diagonal of a rectangular garden measures <math>11\frac{1}{4}</math> m while its width measures <math>6\frac{3}{4}</math> m. Calculate the perimeter of the garden. (2 marks)</p>	

		Working Space
67	<p><b>2011 Q 7 P1</b></p> <p>The external length, width and height of an open rectangular container are 41 cm, 21 cm and 15.5cm respectively. The thickness of the material making the container is 5mm. If the container has 8 litres of water, calculate the internal height above the water level.</p> <p style="text-align: right;">(4 marks)</p>	
68	<p><b>2011 Q 17 P1</b></p> <p>A solid consists of a cone and a hemisphere. The common diameter of the cone and the hemisphere is 12cm and the slanting height of the cone is 10cm.</p> <p>a) Calculate correct to two decimal places;</p> <p style="padding-left: 40px;">i) The surface area of the solid; (3 marks)</p> <p style="padding-left: 40px;">ii) The volume of the solid. (4 marks)</p> <p>b) If the density of the material used to make the solid is <math>1.3\text{g/cm}^3</math>, calculate its mass in kilograms.(3 marks)</p>	

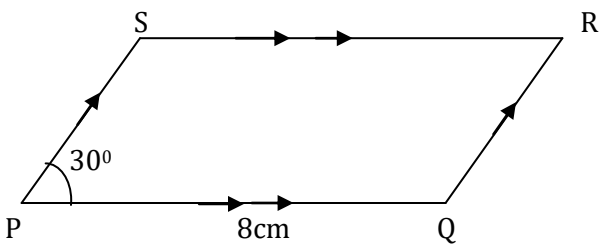
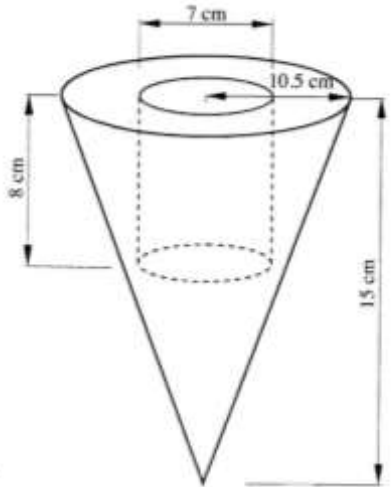
		Working Space
69	<p><b>2012 Q4 P1</b>            In the parallelogram PQRS shown below, <math>PQ=8\text{cm}</math> and angle <math>SPQ = 30^\circ</math></p>  <p>If the area of the parallelogram is <math>24\text{cm}^2</math>, find its perimeter.</p> <p style="text-align: right;">(3marks)</p>	
70	<p><b>2012 Q15 P1</b>            The figure below represents a solid cone with a cylindrical hole drilled into it. The radius of the cone is <math>10.5\text{cm}</math> and its vertical height is <math>15\text{cm}</math>. The hole has a diameter of <math>7\text{cm}</math> and depth of <math>8\text{cm}</math>.</p>  <p>Calculate the volume of the solid.</p> <p style="text-align: right;">(3marks)</p>	

71 **2012 Q18 P1**

The figure below represents a solid cuboid ABCDEFGH with a rectangular base.  $AC = 13\text{cm}$ ,  $BC = 5\text{cm}$  and  $CH = 15\text{cm}$ .

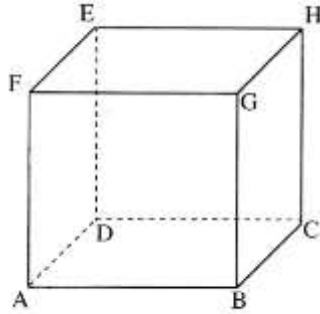

- (a) Determine the length of AB. (1 mark)
- (b) Calculate the surface area of the cuboid (3 marks)
- (c) Given that the density of the material used to make the cuboid is  $7.6\text{g/cm}^3$ , calculate its mass in kilograms. (4 marks)
- (d) Determine the number of such cuboids that can fit exactly in a container measuring 1.5m by 1.2m by 1m. (2 marks)