

# **F4 ENDTERM 2 EXAMS**

## **ALL SUBJECTS**

**SERIES 1**

### **SUJECTS COMPILED:**

*Maths, English, Kiswahili, Biology, Chemistry, Physics, History,  
CRE, Geography, Agriculture, Business Studies.*

***A Collection of well-organized standard updated  
End of Term Two Test Examinations for our Current  
KCSE Candidates in all Schools in Kenya.***

**SERIES 1**

***For marking schemes***

**CALL/TEXT/WHATSAPP 0746 222 000**

**MWALIMU AGENCY**

# FORM 4 ENDTERM 2 EXAMS

# BIOLOGY

## PAPER 1

TIME:2 HOURS

NAME..... ADM NO:.....

SIGN..... DATE;.....

231/1

# BIOLOGY

## PAPER 1

### THEORY

TIME: 2HOURS

### INSTRUCTION TO CANDIDATES

- (a) Write your name and index number in the spaces provided above.
- (b) Answer all the questions.
- (c) Answers must be written in the spaces provided in the question paper.
- (d) Additional pages must not be inserted candidates should check question paper to ascertain that all the pages are printed as indicated and that no questions are missing.
- (e) Candidates should answer the questions in English.

### For Examiner's use only

Question	Maximum score	Candidate's Score
1	17	
2	14	
3	09	
TOTAL	80	

1. State the name given to the study of:

(a) Cell..... (1 mk)

(b) Microorganism..... (1 mk)

2. Name two kidney diaseses (2 mks)

.....  
.....

3. (a) Write the dental formula of an adult man. (1 mk)

.....  
.....

(b) Name two dental diseases (2 mks)

.....  
.....

4. The diagram below represents a certain organism

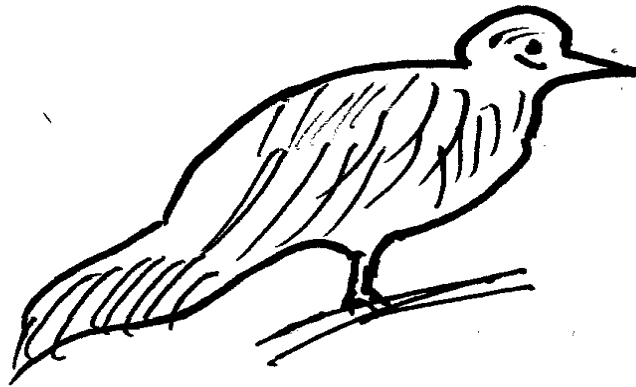

State the phylum and class to which it belongs (2 mks)

Phylum.....

Class .....

5. When are two organism considered to belong to the same species. (2 mks)

.....  
.....

6. State three reasons for classifying organisms (3 mks)

.....  
.....  
.....

7. State four reasons why water is significant in seed germination (4 mks)

.....  
.....  
.....  
.....

8. Satte one function of each ,of the following cell organelles (3 mks)

(a) Lysosomes

.....  
.....

(b) Ribosomes

.....  
.....

(c) Chloroplast

.....  
.....

9. Give the functions of the following parts of microscope (2 mks)

(a) Eye piece lens

.....

(b) Mirror

.....

10. Name the type of skeleton that makes up each of the following animals (2 mks)

(a) Locust

.....

(b) Bird

.....

11. Distinguish between divergent and convergent evolution. (2 mks)

.....  
.....

12. Why are some bacteria able to resist the effect of antibodies. (2 mks)

.....  
.....

13. The table below shows transportation of substances in the human body.

Substance	Transported by blood	
	From	To
Oxygen	M	Whole body
N	Liver	Kidneys
P	intestine	Whole body

Name the substances represented by ;

M..... (1 mk)

N..... (1 mk)

P..... (1 mk)

14. The table below shows the concentration of sodium and iodine in sea water and cell sap of a plant

	Sodium Io concentration	Iodide ion concentration
Sea water	300	35
Cell sap	100	550

(a) (i) Name the process through which the plant cells take up sodium ions. (1 mk)

.....  
 .....

(ii) Give a reason for your answers in (a) (i) above (1 mk)

.....  
 .....

15. The diagram below shows a transverse section of plant organ

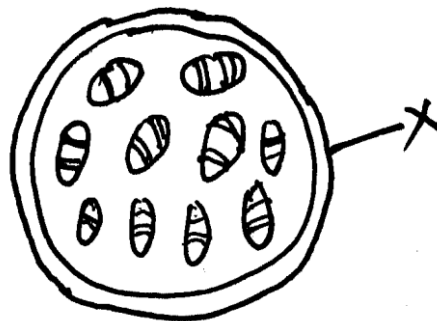

(a) Name the plant organ from which this section was obtained (1 mk)

.....  
 .....

(b) (i) Name the class to which the plant organ was obtained. (1 mk)

.....  
 .....

(ii) Give a reason for your answer in (b)(i) above (1 mk)

.....  
 .....

(c) Name the part labeled X. (1 mk)

.....  
 .....

16. The diagram below shows a red blood cell that was subject to a certain treatment

(a) Account for shape of cell at the end of the experiment (2 mks)

.....  
 .....

(b) State 3 roles of osmosis in plants (3 mks)

.....  
 .....

.....  
.....

17. Name the sites where light and dark reactions of photosynthesis take place. (3 mks)

(a) Light reaction.....

(b) Dark reaction .....

18. State three characteristics of living organism that are specific to plants. (3 mks)

.....  
.....  
.....

19. (a) What is meant by the term sex-linked genes. (1 mk)

.....

(b) State three sex linked traits in human beings (2 mks)

.....  
.....  
.....

20. Name the flower part that produces gametes. (2 mks)

.....  
.....  
.....

21. (a) State three structural differences between arteries and vein in mammals (3 mks)

.....  
.....  
.....

(b) Name a diseases that causes thickening and hardening of arteries. (1 mk)

.....

22. What is the function of the following structures in the human reproductive organs. (3 mks)

(a) Fallopian tubes.....

(b) Epididymis.....

(c) Scrotal sac.....

23. The diagram below illustrates a response by a certain plant

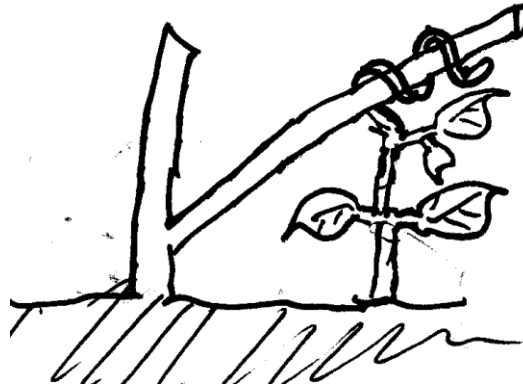

(a) Name the type of response (1mk)

.....

(b) Explain how the response illustrated above occurs (3 mks)

.....

.....

.....

24. The diagram below represents recycling of nutrients in a certain ecosystem,

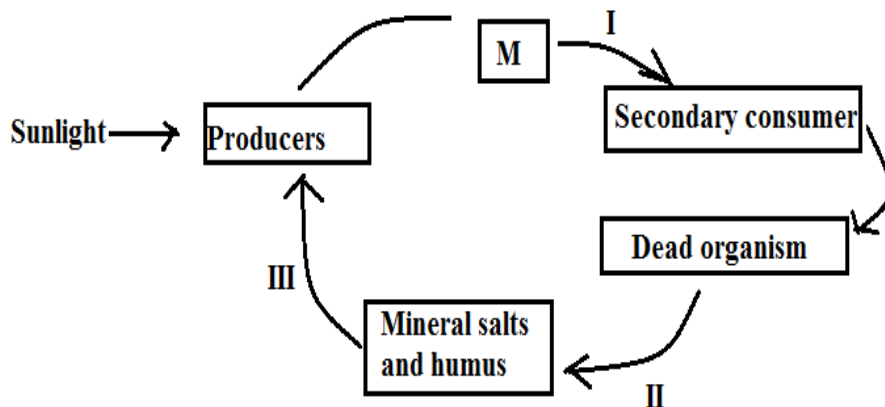

(a) Name the trophic level represented by M.

(b) Name the process represented by I, II, III (3 mks)

.....

.....

25. Explain why it is not advisable to be in a poorly ventilated room with a burning charcoal stove.

(3 mks)

.....

.....

.....

26. State two support tissues in plants.

(2 mks)

.....  
.....

27. The diagram below illustrates a nerve cell.

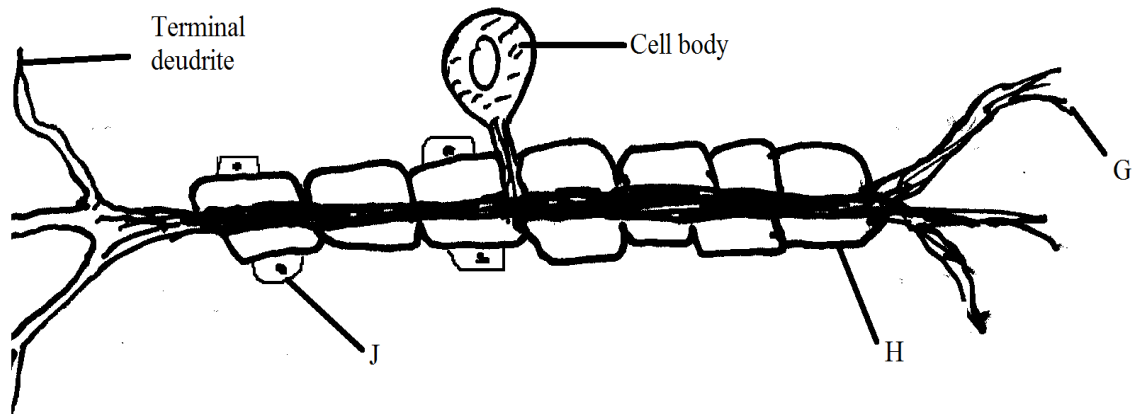

(a) Name the type of nerve cell illustrated. (1 mk)

.....

(b) Give a reason for your answer in (a) above (1 mk)

.....

(c) Identify the part labeled J. (1 mk)

.....

(d) State one function of each of the parts labeled G and H. (2 mks)

.....

.....

(e) Using an arrow indicate the direction of impulse on the diagram. (1 mk)



# FORM 4 ENDTERM 2 EXAMS

# BIOLOGY

PAPER 2

TIME:2 HOURS

NAME..... ADM NO:.....

SIGN..... DATE;.....

231/2

## BIOLOGY

Paper 2

**THEORY**

**Time: 2 Hours**

### INSTRUCTION TO THE CANDIDATES

- (a) Write your name and index number in the spaces provided above
- (b) This paper consists of two sections; A and B. answer all questions in section A and in section B answer question 6 (compulsory) and either question 7 or 8 in the space provided after question 8

### FOR EXAMINERS USE ONLY

section	question	Maximum score	Candidates score
A	1	8	
	2	8	
	3	8	
	4	8	
	5	8	
B	6	20	
	7 or 8	20	
TOTAL		80	

1. The diagram below shows a section through the mammalian nephron.

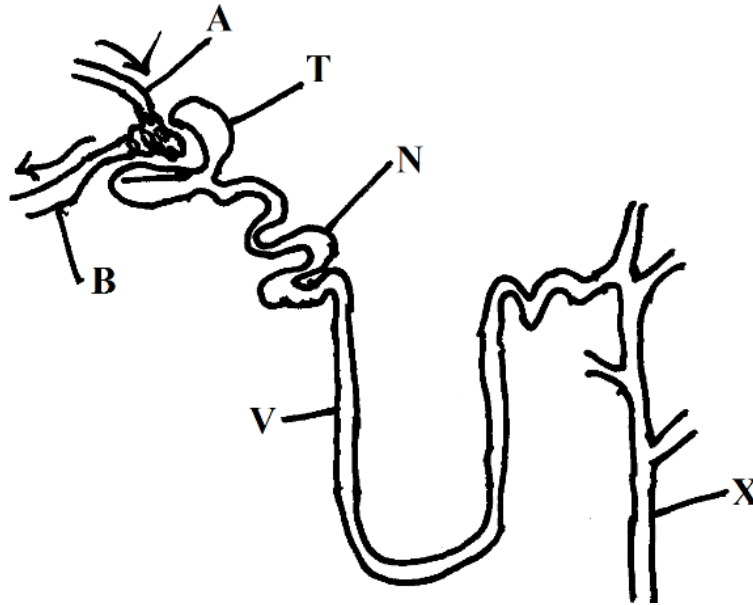

(a) Name the structures labeled : A, B and N. (3mks)

A \_\_\_\_\_

B \_\_\_\_\_

N \_\_\_\_\_

(b) Name all the structures in a nephron which are normally present in the cortex region of kidney. (1mk)

.....

(c) Which region in the nephron deals with conservation of body water. (1mk)

.....

(d) Name the hormone that has an effect on part labeled X. (1mk)

.....

(e) How is part labelled N adapted to its function. (2mks)

.....

.....

.....

2. In a fish pond the number of fish were estimated by use of the following data.

First captured = 50

Second capture = 90

Marked recaptured = 25

(a) Identify the method suggested above. (1mk)

.....  
(b) Name other two sampling methods used in estimating populations. (2mks)

.....  
(c) Calculate the number of fish in the pond. (2mks)

.....  
(d) Give three assumptions of the above method. (3mks)

.....  
3. The figure below shows a light microscope. Use it to answer questions below.

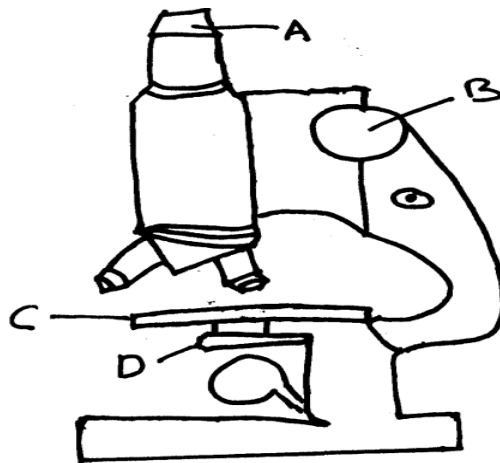

(a) Name the parts labeled B, C and D. (3mks)

B \_\_\_\_\_

C \_\_\_\_\_

D \_\_\_\_\_

(b) State three differences between an electron microscope and a light microscope. (3mks)

- (c) Calculate the magnification which is obtained when an object is viewed with a x15 eye piece and x20 objective lens.

.....  
.....  
.....  
.....

4. The presence or absence of horns in cattle is an inherited trait.

Horns X no horns



All with no horns



Some with horns and some without horns

- (a) Using letter H and h, give the genotypes for horns and no horns. **(2mks)**

.....  
.....  
.....

- (b) Show the result of crossing the F<sub>1</sub> generation; all of whom lack horns. **(4mks)**

.....  
.....  
.....  
.....

- (c) A farm produced a total of 72 calves without horns from cross in (b) above. Calculate the percentage of calves with horns. **(2mks)**

.....  
.....  
.....  
.....

5. (a) Give any four evidences for organic evolution. **(4mks)**

.....

.....  
.....  
.....  
.....

(b) State significant ways in which human beings differ from other animals. (3mks)

.....  
.....  
.....  
.....

(c) In view of modern genetics why is Lamerkian theory unacceptable. (1mk)

.....  
.....  
.....

**SECTION B (40 MARKS)**

**Answer question 6 (compulsory) and either question 7 or 8 in the spaces provided after**

6. During germination of a maize plant, the dry weight of endosperm and the dry weight of embryo were determined at two days interval. The result are shown below.

Time after planting (Days)	Dry weight of endosperm (mg)	Dry weight of embryo (mg)
0	50	4
2	45	4
4	36	9
6	25	21
8	13	28
10	8	36
12	5	42

(a) Using the same axis, draw graphs of dry weight of endosperm and embryo against time. (8mks)

(b) What was the dry weight of endosperm no day 5? (1mk)

.....

(c) Account for increase of dry weight of embryo between 2<sup>nd</sup> and 12<sup>th</sup> day. (2mks)

.....  
.....

.....

(d) State two causes of seed dormancy in a seed. (2mks)

.....  
.....  
.....  
.....

(e) Explain the importance of following factors in germination.

(i) water (4mks)

.....  
.....  
.....  
.....  
.....

(ii) oxygen (2mks)

.....  
.....  
.....  
.....

(iii) optimum temperature (1mk)

.....  
.....  
.....

7. (a) State four characteristics of gaseous exchange surfaces. (4mks)

(b) Describe the mechanism of gaseous exchange in a mammal. (16mks)

8. Using a relevant example in each case; describe simple and conditional reflex actions. (20mks)

.....  
.....  
.....  
.....

.....  
.....  
.....  
.....  
.....  
.....  
.....  
.....  
.....  
.....  
.....  
.....  
.....  
.....  
.....  
.....  
.....  
.....  
.....  
.....  
.....  
.....  
.....  
.....  
.....  
.....  
.....  
.....  
.....  
.....  
.....  
.....  
.....  
.....  
.....  
.....  
.....  
.....  
.....  
.....  
.....  
.....  
.....  
.....  
.....  
.....  
.....  
.....  
.....  
.....  
.....  
.....  
.....  
.....  
.....





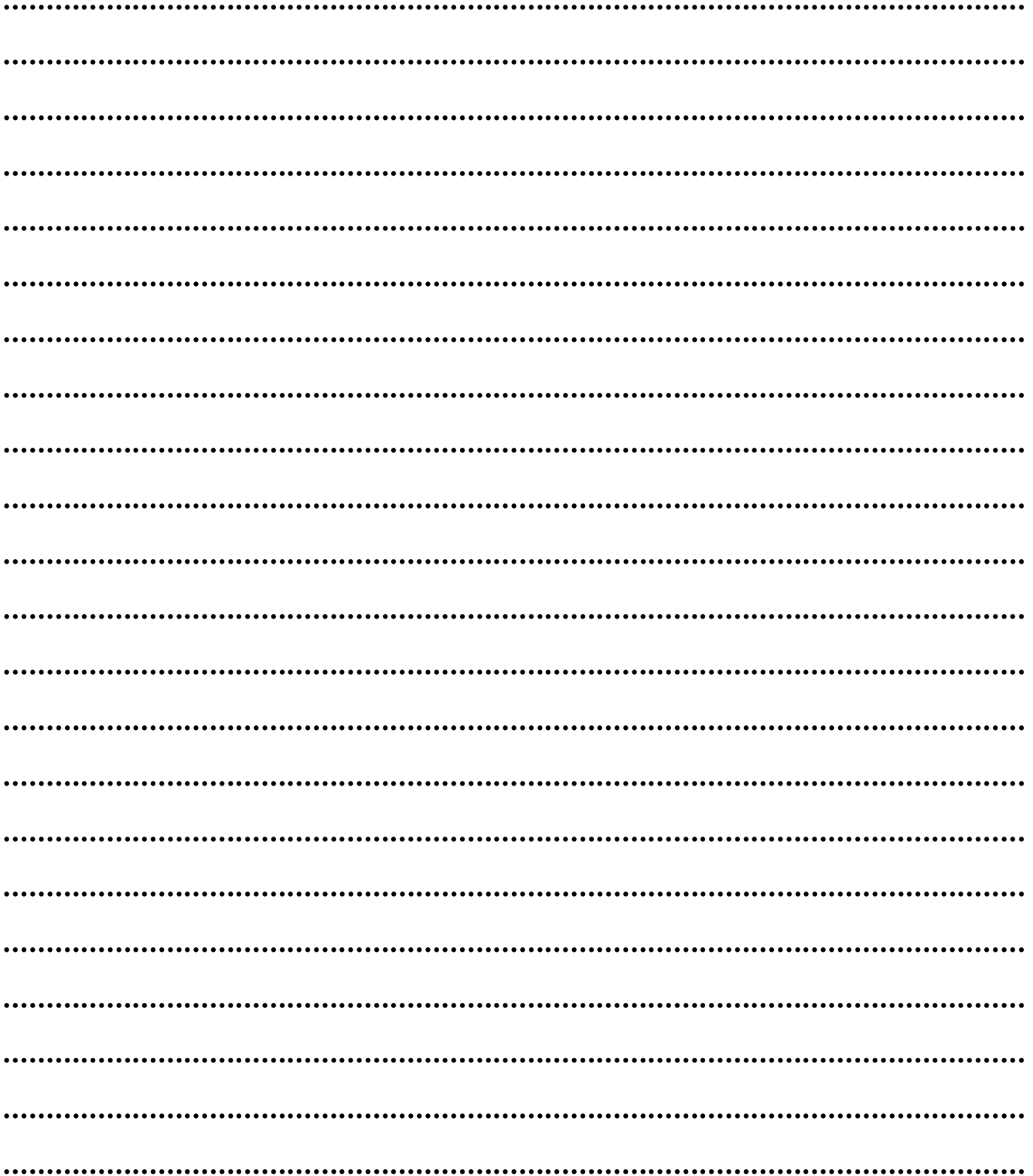

***FOR MARKING SCHEMES CALL/WHATSAPP 0746 222 000***

# FORM 4 ENDTERM 2 EXAMS

## CHEMISTRY

### PAPER 1

TIME:2 HOURS

NAME..... ADM NO:.....

SIGN..... DATE;.....

### INSTRUCTION TO CANDIDATES

1. Write your name and Index number in the spaces provided above
2. Sign and write the date of the examination in the spaces provided
3. Answer all the questions in the spaces provided
4. All working must be clearly shown where necessary.
5. Candidates should check to ascertain that each page s printed as indicated and that no question is/are missing.

### FOR EXAMINER'S USE ONLY

Question	Maximum score	Candidate's score
TOTAL	80	

1. A mixture containing equal volumes of hydrogen and carbon (iv) oxide was introduced on one end of a tube as shown .

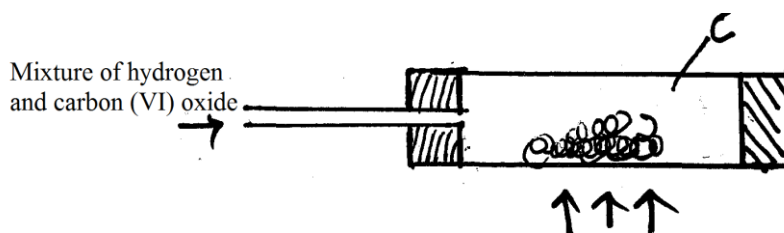

Which gas would be detected at point C first Explain. (2 mks)

.....

.....

.....

2. The electron arrangement of ions  $X^{3+}$  and  $Y^{2-}$  are 2.8 and 2.8.8 respectively.

(a) Write the electron arrangement of elements X and Y. (2 mks)

.....

.....

(b) Write the formula of the compound that would be formed between X and Y. (1 mk)

.....

3. The curve below represents the variation of temperature with time when pure and impure samples of solid were heated separately.

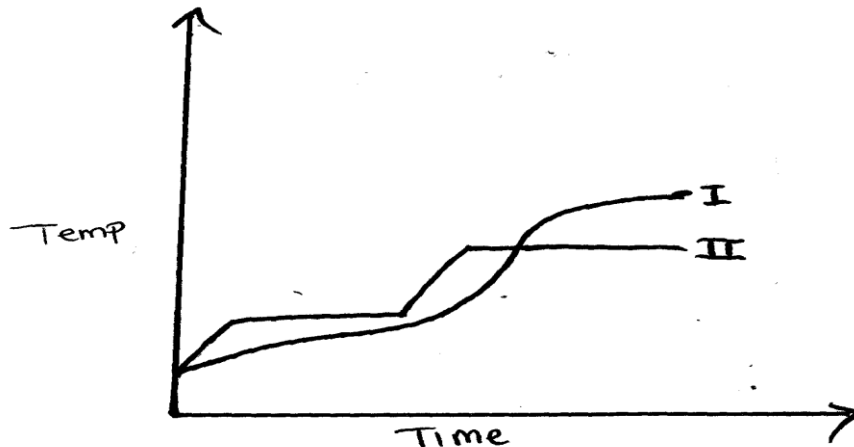

Which curve shows the variation in temperature for the pure solid? Explain, (2 mks)

.....

.....

.....

4. In the redox reaction below

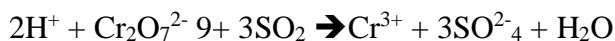

Identify the reducing agent, explain your answer, (2 mks)

.....

.....

.....  
5. Calculate the heat of formation of carbon (II) oxide from the following data (3 mks)



6. State and explain using equations the changes in mass that occur when metallic copper and copper (II) carbonate are separately heated in open crucibles. (3 mks)

.....  
.....  
.....  
.....

7. Study the flow chart below and answer the questions that follow.

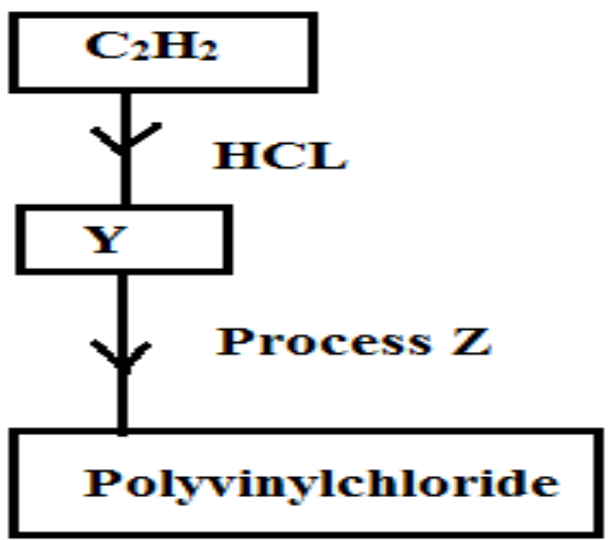

(a) Identify substance Y. (1 mk)

.....

(b) Identify process Z (1 mk)

.....

(c) State two uses of polyvinylchloride (1 mk)

.....

.....

8. Nitrogen (iv) oxide can be prepared using the set up below.

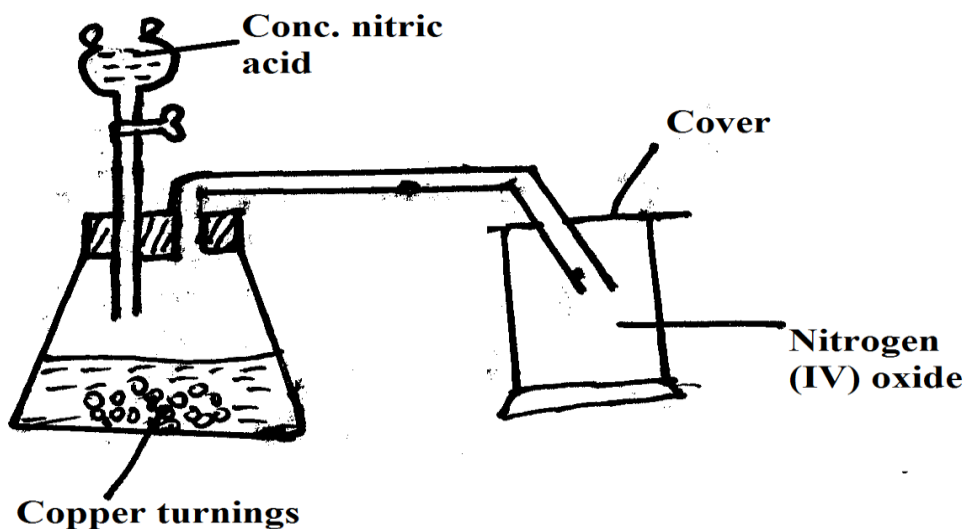

(a) Write an equation for the reaction taking place in flask. (1 mk)

(b) What property of the gas makes it possible to be collected using the method shown (1mk)

9. The table below gives the solubilities of potassium bromide and potassium sulphate at 0°C and 40°C.

Substance	Solubility in g/100g water at	
	0°C	40°C
Potassium bromide	55	75
Potassium sulphate	10	12

When an aqueous mixture containing 60g of potassium bromide and 7g of potassium sulphate in 100g of water at 80°C was cooled to 0°C, some crystals were formed. (1 mk)

(i) Identify the crystals. (1 mks)

(ii) Determine the mass of the crystals formed. (1 mk)

(iii) Name the method used to obtain the crystals. (1 mk)

10. Complete the diagram below to show how alpha, beta and gamma emissions from a radio active source can be distinguished from each other. Label your diagram. (3 mks)

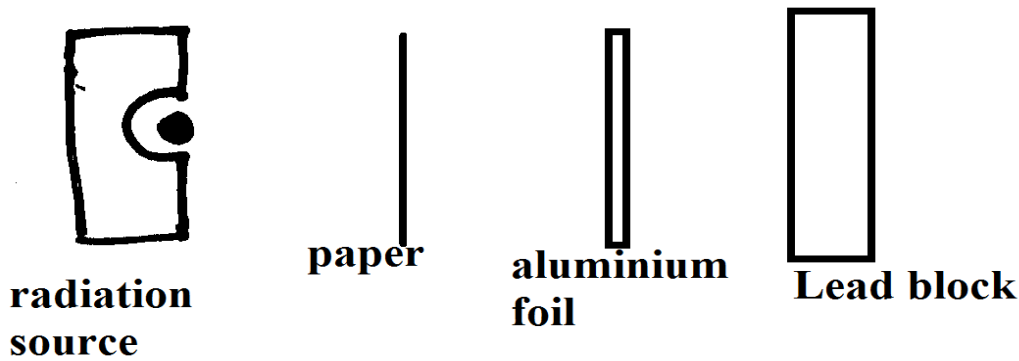

11.  $20\text{cm}^3$  of a solution containing  $4\text{g/l}$  of sodium hydroxide was neutralized by  $8\text{cm}^3$  of dilute sulphuric acid. Calculate the concentration of sulphuric acid in moles per litre.  
 (Na=23, O=16, H=1) (3 mks)

12. (a) After use, a non-luminous flame should be put off or adjusted to luminous flame. Explain why? (2 mks)

.....  
 .....

- (b) Explain how the hotness of a Bunsen burner can be increased. (1 mk)

.....  
 .....

13. When steam was passed over heated charcoal as shown in the diagram below; hydrogen and carbon (ii) dioxide were formed.

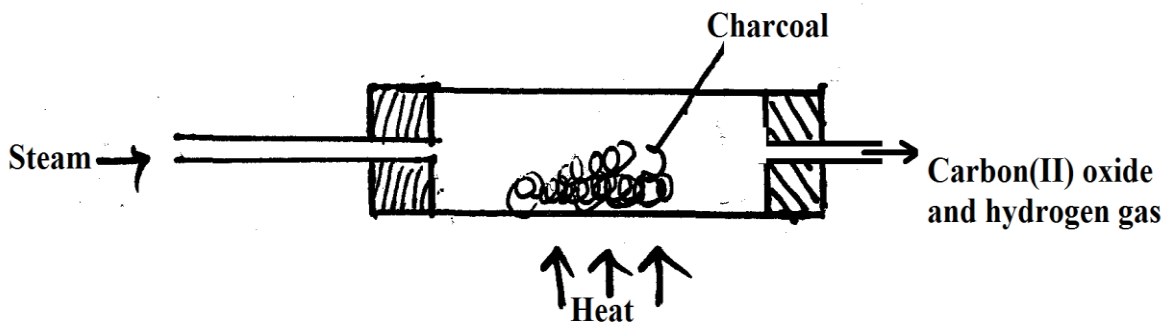

- (a) Write the equation for the reaction which takes place. (1 mk)

.....

.....  
(b) Name two uses of carbon (ii) oxide gas which are also uses of hydrogen. (2 mks)  
.....  
.....

14. Two solutions containing cations of metals P and Q were separately added to a solution containing chloride ions in both cases, a white precipitate was formed. It was divided into two portions. To the first portion, a few drops of nitric acid was added. The chloride compound of P was warmed. The chloride compound of Q dissolved while of P did not.

(a) Identify the ions of metal P and Q. (1 mk)  
.....  
.....

(b) Write ionic equation for the reactions that occurred when cations of P and Q reacted with chloride ions. (1 mk)  
.....

15. (a) Name the raw materials from which sodium is extracted. (1 mk)  
.....

(b) Give a reason why sodium is extracted using electrolysis. (1 mk)  
.....

(c) Give two uses of sodium metal. (1 mk)  
.....

16. A polymer has the following structure

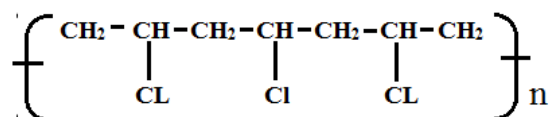

A sample of this polymer is found to have a molecules mass of 750, Determine the numbers of monomers in the polymer (H=1, Cl=35.5, C=12) (2 mks)

The table below shows the PH values of solution I, II, III and IV.

Solution	I	II	III	IV
PH	2	7	11	14

17. (a) Which solution is likely to be calcium hydroxide. (1 mk)  
.....

(b) Select two solution in which aluminium oxide is likely to dissolve. Give a reason. (2 mks)  
.....

- .....  
 .....  
 18. During the production of hydrogen Iodide, hydrogen reacts with iodine according to the following equation.

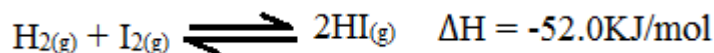

Explain how the following would affect the yield of hydrogen Iodide.

- (i) Increase in temp (1 mk)

.....  
 .....

- (ii) Increase in pressure (1 mk)

.....  
 .....

19. Give two reasons why Helium is used in weather balloons. (2 mks)

.....  
 .....  
 .....

20. Below is a sketch of graph showing the change in viscosity (ease of flow) with temperature when solid sulphur is heated.

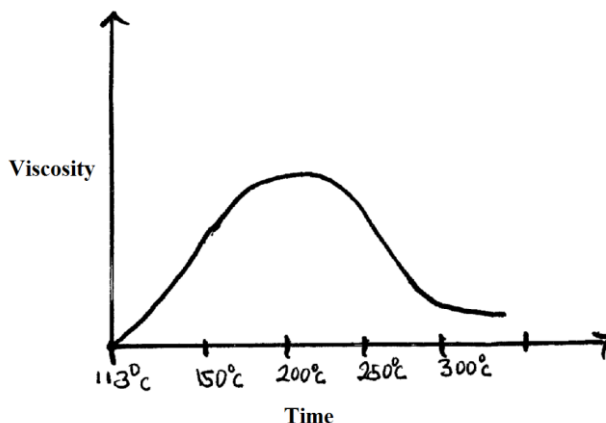

- Describe what happens to the sulphur molecules when sulphur is heated from 150°C to about 200°C. (3 mks)

.....  
 .....  
 .....  
 .....

21. Both graphite and diamond are allotropes of carbon. Graphite conducts electricity while diamond does not. Explain. (2 mks)

.....



.....  
.....  
22. The diagram below shows a student's set up for the preparation and collection of hydrogen gas.

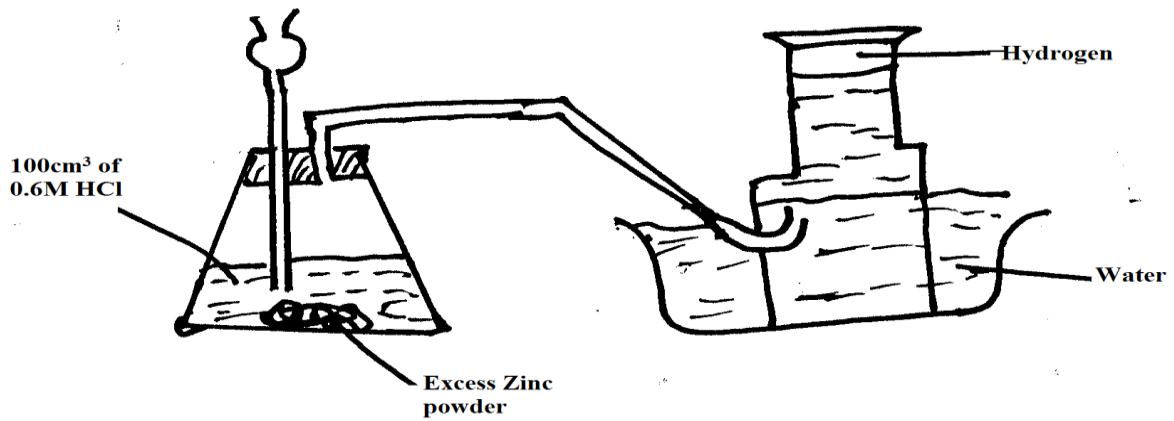

(a) Write an equation for the production of hydrogen gas. (1 mk)

.....  
(b) State and explain how the final volume of hydrogen gas produced would be affected if 80cm<sup>3</sup> of 0.75m hydrochloric acid was used. (3 mks)

23. The drawings below illustrates a process

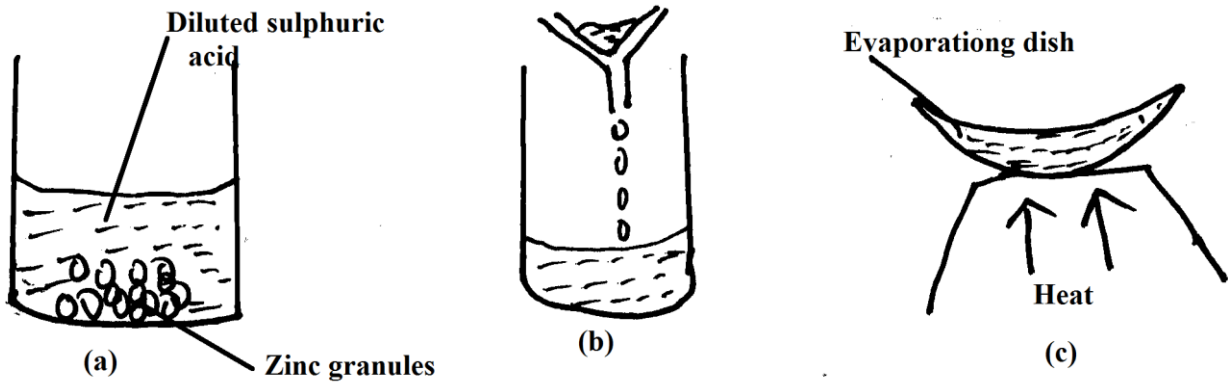

Describe the process. (3 mks)

.....  
.....  
.....  
.....

24. When a current of 0.82A was passed for 5 hours through a solution of metal Z, 2.65g of the metal was deposited. Determine the charge on the ion of metal Z. (3 mks)

25. Describe the process by which nitrogen is obtained from air on a large scale. (3 mks)

.....  
.....  
.....  
.....  
.....

26. The curves below were obtained when two equal volumes of hydrogen peroxide of the same concentration were allowed to decompose separately. In one case, manganese (IV) oxide was added to the hydrogen peroxide.

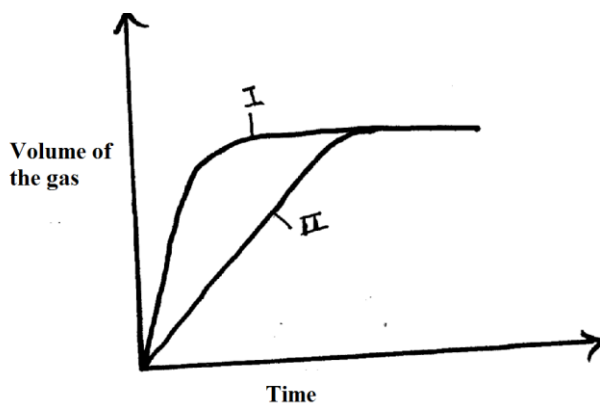

Which curve represents the decomposition of hydrogen peroxide with manganese (IV) oxide.

Explain. (3 mks)

.....  
.....  
.....  
.....  
.....  
.....

27. (a) Distinguish between endothermic and exothermic reaction. (1 mk)

.....  
.....

(b) Draw a well labeled diagram for an exothermic reaction. (2 mks)

28. A volume of  $120\text{cm}^3$  of nitrogen gas diffused through a membrane in 40 seconds, how long will  $240\text{cm}^3$  of carbon (IV) oxide diffuse through the same membrane. (3 mks)

29. (a) The table below contains atoms that form common radicals. Complete the table to show radicals formed from various atoms. (2 mks)

Element	N	S
H	$\text{NH}_4^+$	

(b) What is a radical. (1 mk)

.....

# FORM 4 ENDTERM 2 EXAMS

## CHEMISTRY

### PAPER 2

TIME:2 HOURS

NAME..... ADM NO:.....

SIGN..... DATE;.....

#### INSTRUCTION TO CANDIDATES

1. Write your name and Index number in the spaces provided above
2. Sign and write the date of the examination in the spaces provided
3. Answer all the questions in the spaces provided
4. All working must be clearly shown where necessary.
5. This paper consists of 12 printed pages
6. Candidates should check to ascertain that each page is printed as indicated and that no question is/are missing.

#### FOR EXAMINER'S USE ONLY

Question	Maximum score	Candidate's score
TOTAL	80	

1. In an experiment, a piece of magnesium was cleaned with steel wool. 2.4g of the cleaned magnesium was placed in a crucible and completely burned in oxygen. After cooling the product weighed 4.0g.

(a) Explain why it was necessary to clean the magnesium ribbon. (1 mks)

.....  
 .....

(b) What observation was made in the crucible after burning. (1 mk)

.....  
 .....

(c) Why was there an increase in mass? (1 mk)

.....

(d) Work out the empirical formula of the product (Mg=24.0, O=16.0) (3 mks)

(e) What was the aim of the experiment? (1 mk)

.....  
 .....

(f) The product was shaken with dilute nitric acid and filtered.

(i) What type of reaction occurred (1 mk)

.....

(ii) Write an equation for the reaction. (1 mk)

.....  
 .....

2. The flow chart below shows part of the process involved in large scale manufacturing of sulphuric (VI) acid. Use it to answer the questions that follow.

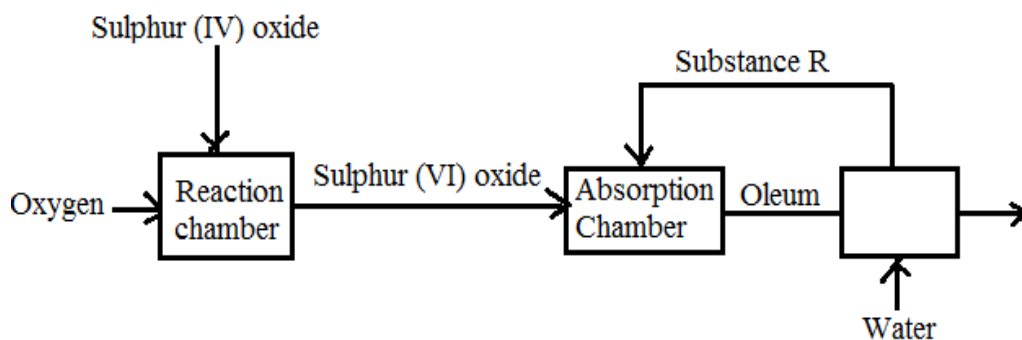

(a) Identify two conditions required for a high yield of sulphur (VI) oxide in the reaction chamber (2 mks)

.....

.....  
(b) Name substance R. (1 mk)

.....  
(c) Write an equation for the reaction occurring in the absorption chamber (2 mks)

.....  
(d) Give one pollution affect of the process (1 mk)

.....  
(e) Complete the table below to show the observation made when concentrated sulphuric (VI) acid is added to the substances shown. (2 mks)

Substance	Observation
Iron fillings	
Sugar crystals	

(d) Zinc reacts with both concentrated and dilute sulphuric (VI) acid. Explain (2 mks)

.....  
(g) Sulphuric acid contains sulphate ions. Explain how these ions are confirmed. (2 mks)

.....  
(h) Give one use of sulphuric acid. (1 mk)

3. (a) Identify the chief ore of iron. (1 mk)

.....  
(b) The extraction of iron takes place in a blast furnace as shown below.

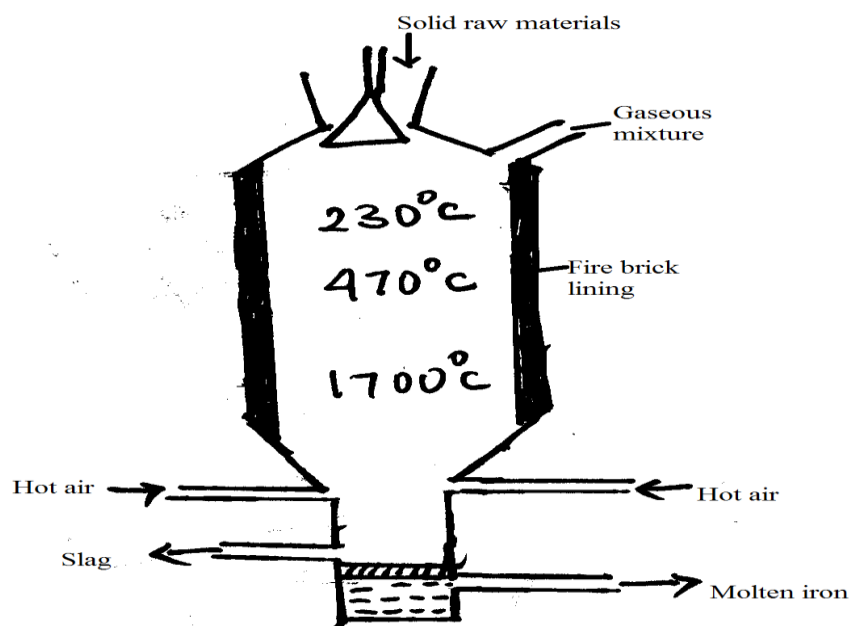

(i) Other than the iron are name other two raw materials put in the furnace. (2 mks)

.....  
.....  
.....

(ii) Describe the process which leads to the formation of iron in the blast furnace. (3 mks)

(iii) State the purpose of limestone in the blast furnace. (1 mks)

.....  
.....

(iv) Give a reason why the melting point of the iron obtained from the blast furnace is 1200<sup>0</sup>C while that of pure iron is 1533<sup>0</sup>C (2 mks)

.....  
.....

(v) Give one gas which is recycled (1 mk)

.....  
.....

(vi) State one physical property of mother slag that allows it to be separated from mother iron as shown in the figure. (1 mk)

.....  
.....

(vii) State one use of steel (1 mk)

4. The diagram below is part of a set up used to prepare and collect dry chlorine gas.

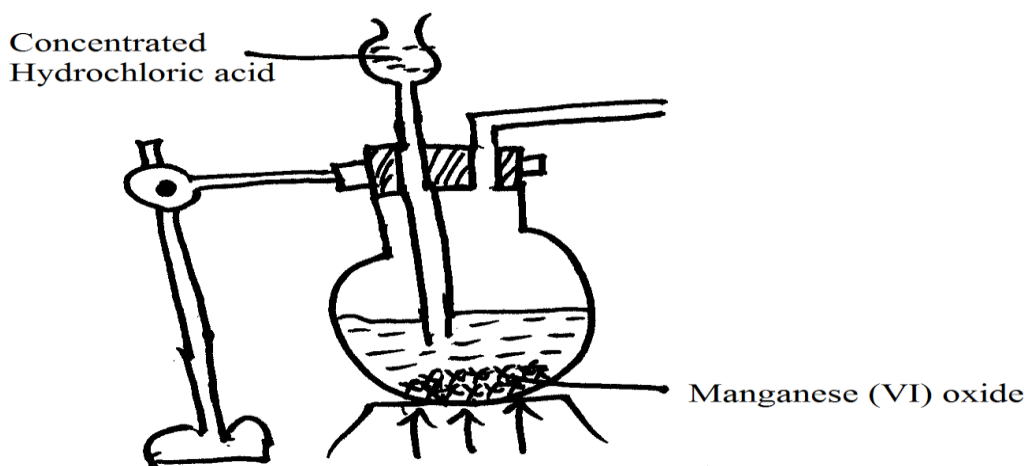

(i) Complete the diagram to show how a dry sample of chlorine gas can be collected. (3 mks)

(ii) Write an equation for the reaction forming chlorine. (1 mks)

.....

(iii) Other than the manufacturing of weed killers name two (2) uses of chlorine. (2 mks)

.....

.....

(v) 0.8g of aluminum reacted completely with chlorine gas. Calculate the volume of chlorine gas used. (Molar gas volume is  $24\text{dm}^3$ , Al=27.0) (3 mks)

5. (a) The scheme below shows some of the reaction of solution Q. Study it and answer the question that follows.

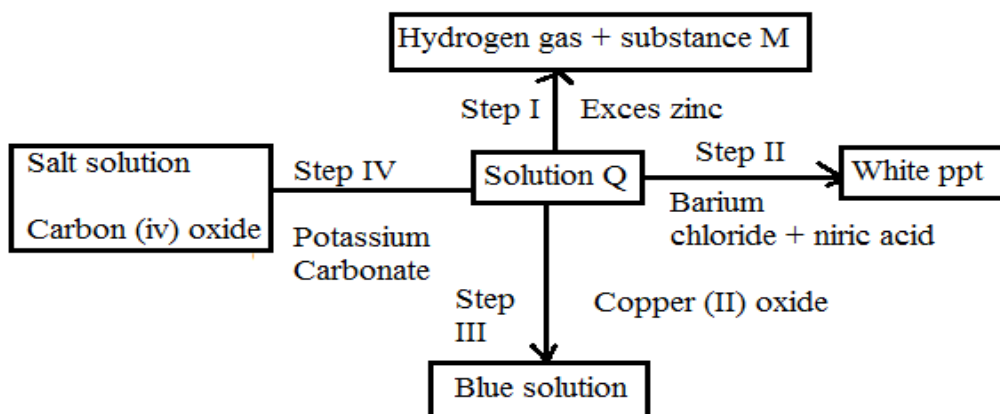

(i) Give possible identity of substance M and Z (2 mks)

.....

.....

(ii) Identity the anion in solution Q (1 mk)

.....

(iii) What type of reaction occurs at step I and II (2 mks)

.....

.....

(iv) Write an equation for the reaction occurring at step IV (1 mk)

.....

(v) Explain how a sample of substance D can be obtained from the salt solution D. (2 mks)



.....  
 .....  
 .....

(vi) What difference in the observation would be made if sodium chloride solution is used instead of barium chloride at step II. (2 mks)

.....  
 .....  
 .....

(b) Describe how a sample of iron chloride can be prepared by direct synthesis. (3 mks)

.....  
 .....  
 .....

6. (a) Below is a radio active decay series starting from;

$^{210}_{83}\text{Bi}$  and ending at  $^{210}_{81}\text{Pb}$

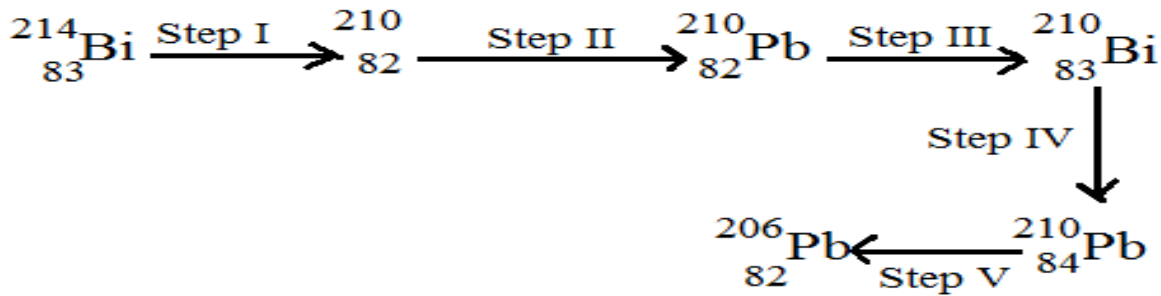

(i) Identify the particles emitted in steps I and III (2 mks)

.....  
 .....

(ii) Write the nuclear equation for the reaction which occurred in step V. (1 mk)

.....  
 .....

(b) The table below gives the percentage of a radioactive isotope o Bismuth that remain after decaying at different times.

Time (min)	0	6	12	22	38	62	100
Percentage of Bismuth	100	81	65	45	29	12	3

(i)

Plot a graph of the percentage of Bismuth remaining (vertical axis) against time .

**(4 mks)**

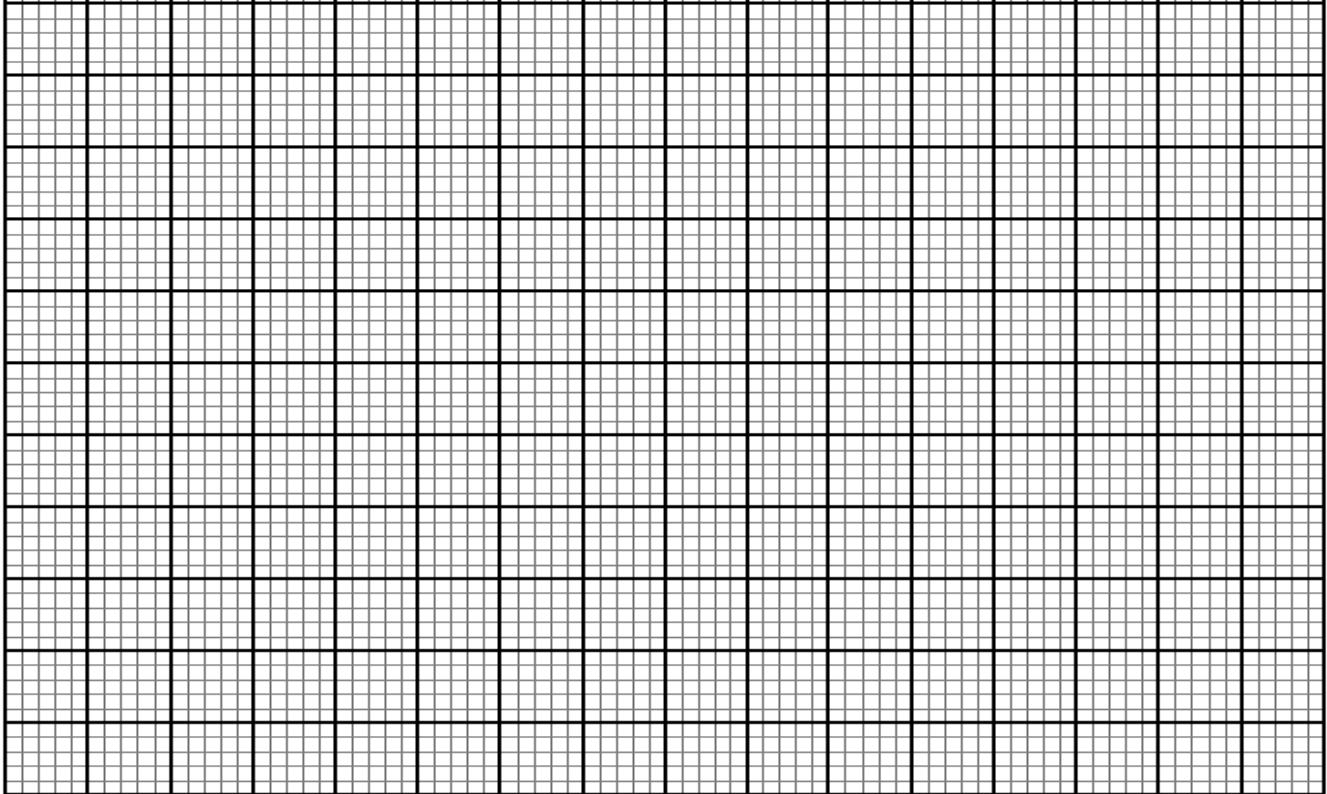

(ii) Using the graph, determine the;

I. Half life of the Bismuth isotope

(1 mk)

II. Original mass of the Bismuth isotope given that the mass remained after 70 minutes was 0.16g.

(2 mks)

(e) Explain why it is not safe to dissolve radioactive substances in containers made of aluminum sheets.

**(2 mks)**

.....  
 .....

.....  
(d) Distinguish between nuclear fission and nuclear fusion.

**(1 mk)**

7. Determine the molar enthalpy of combustion of ethanol, (density of water =  $1\text{ g/cm}^3$ , specific heat capacity of water =  $4.2\text{ J/Kg/K}$ , C=12.0, O=16.0, H=1.0)

**(9 mks)**

# FORM 4 ENDTERM 2 EXAMS

## PHYSICS

### PAPER 1

TIME:2 HOURS

NAME..... ADM NO:.....

SIGN..... DATE;.....

#### INSTRUCTIONS TO CANDIDATES

1. Write your name and index number in the spaces provided
2. Sign and write the date of examination in the spaces provided
3. This paper consists of **TWO** sections A and B
4. Answer **ALL** questions in the spaces provided
5. Mathematical table and electronic calculators may be used.
6. **ALL** working **MUST** be shown clearly where necessary.

*Take: acceleration due to gravity  $g = 10ms^2$*

#### FOR OFFICIAL USE ONLY

SECTION	QUESTION	MAXIMUM SCORE	CANDIDATE'S SCORES
A	1 - 12	25	
B	13	11	
	14	12	
	15	12	
	16	16	
	17	11	
		<b>TOTAL SCORE</b>	80

1. a) Distinguish between the shadow formed by a point source of light and by an extended source of light. (2 mks)

**FOR MARKING SCHEMES CALL/WHATSAPP 0746 222 000**

.....  
.....  
.....

b) The following figure shows two mirrors inclined at an angle of  $30^\circ$  to each other. A ray of light is incident on one mirror as shown below.

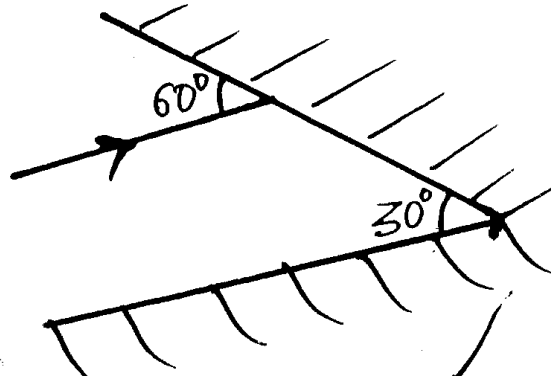

On the diagram, trace the reflected ray (2 mks)

2. An object 5cm high is placed 5 cm from a concave mirror of focal length 10cm. By scale drawing, determine ,
- (i) Image size
  - (ii) Image distance
  - (iii) Nature of image formed

On the grid provided. (4 mks)

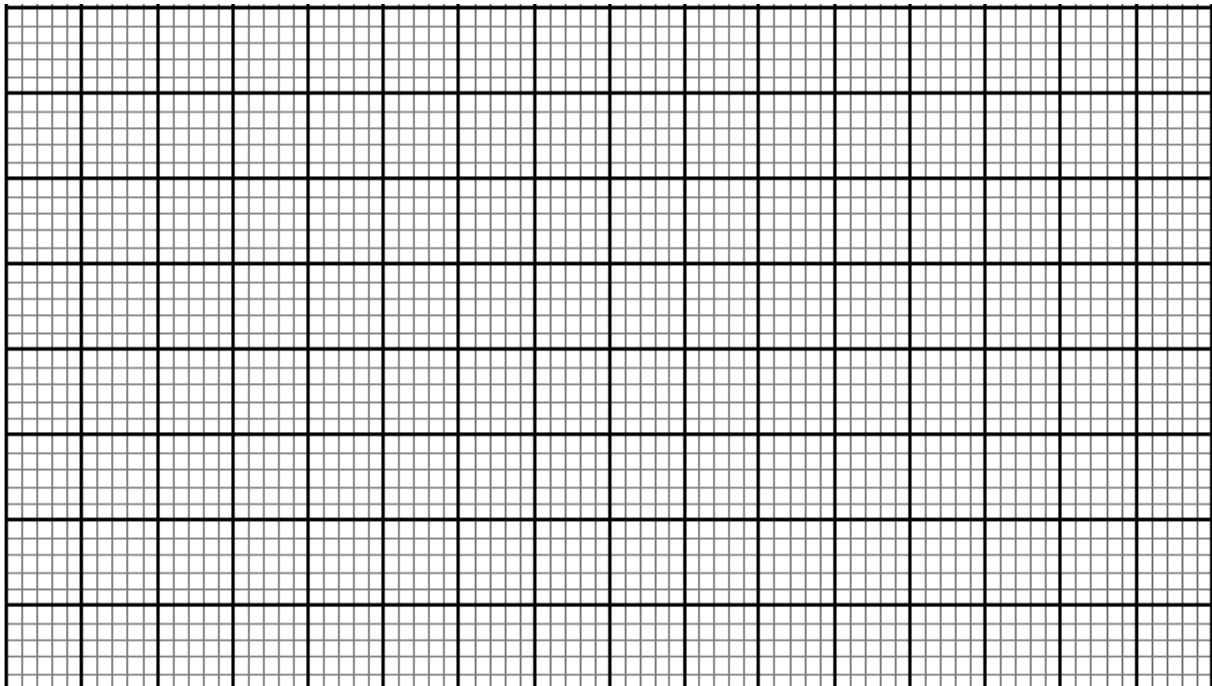

3. Give two similarities between a camera and human eye (2 mks)

.....  
.....

- .....
4. (a) A battery is rated at 70Ah. How long will it work if it steadily supplies a current of 4A. (1 mk)
- (b) State one advantage of a lead-acid accumulator over a dry cell. (1 mk)
- .....
- .....

5. Two identical spheres A and B each standing on an insulated base are in contact. A negatively charged rod is brought near sphere A as shown below.

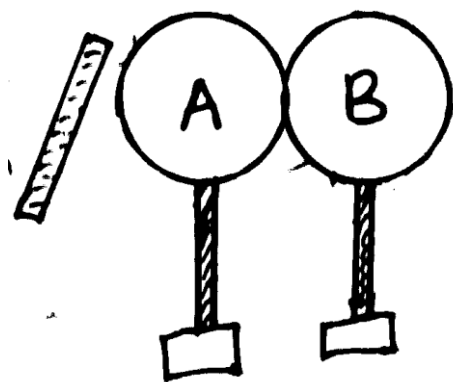

In what way will A differ from B if separated while the rod is near? (1 mk)

.....

.....

6. (a) Give two factors affecting capacitance of a capacitor. (2 mks)

.....

.....

.....

(b) A  $2 \mu F$  capacitor is charged to a potential difference of 120V. Find the energy stored in it. (2 mks)

7. The figure below represents an oscillation taking place at a particular point while a sound wave in a gas passes the point. The vertical axis is labelled displacement.

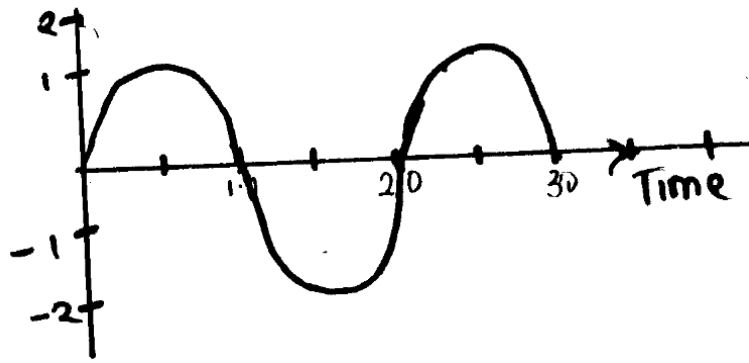

i) Explain what is meant by displacement in this context. (2 mks)

.....

.....

.....

.....

ii) From the figure above determine

(a) The period (1 mk)

(b) The frequency (1 mk)

8. An x-ray machine produces radiation of wavelength  $1.0 \times 10^{-11}$ , calculate;

(a) The frequency of the radiation (2 mks)

(b) Its energy content (Plank's constant to be  $6.63 \times 10^{-34}$  Js) (2 mks)

9. (a) Give three factors that determine heating effect by an electric current. (3 mks)

.....

.....

.....

.....

(b) A 60w bulb is used for 36 hours, determine;

(i) The energy consumed in Kwh (1 mk)

(ii) The cost of using the bulb for 36 hours at sh. 1.55 per Kwh. (1 mk)

(c) The figure below represents part of an electric cooker coil.

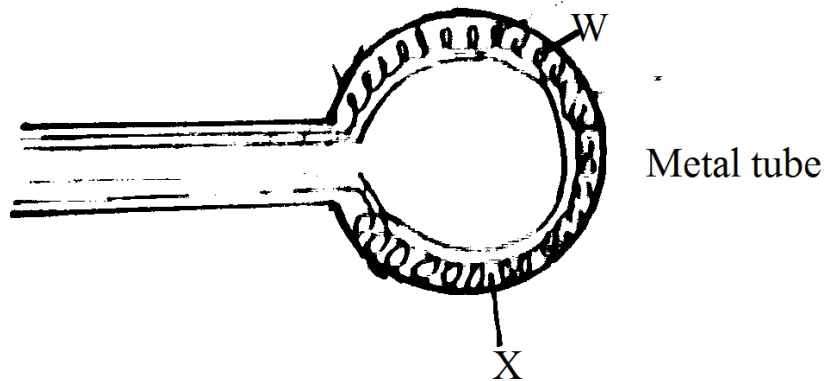

(i) State why the part labelled W is coiled (1 mk)

.....  
.....

(ii) State the property of material X that makes it suitable for its use. (1 mk)

.....  
.....

(d) (i) What is the use of a fuse in an electric circuit (1 mk)

.....  
.....

(ii) State the advantage of transmitting power at

(a) Very high voltage (1 mk)

.....  
.....

(b) Alternating voltage (1 mk)

.....  
.....

10. (a) State any two properties of magnets (2 mks)

.....  
.....  
.....

(b) Why is it that repulsion is the surest test of polarity of a magnet as opposed to attraction.

(2 mks)

.....  
.....  
.....



(c) Use the domain theory to explain the process of magnetism. (2 mks)

.....  
.....  
.....

d) i) Draw the magnetic field pattern around the magnets below



ii) Give one application of thin behaviour of soft iron. (1 mk)

.....

(e) The figure shows a cross-section of a bicycle dynamo. The wheel is connected by an axle to a permanent cylinder magnet and is rotated by the bicycle tyre.

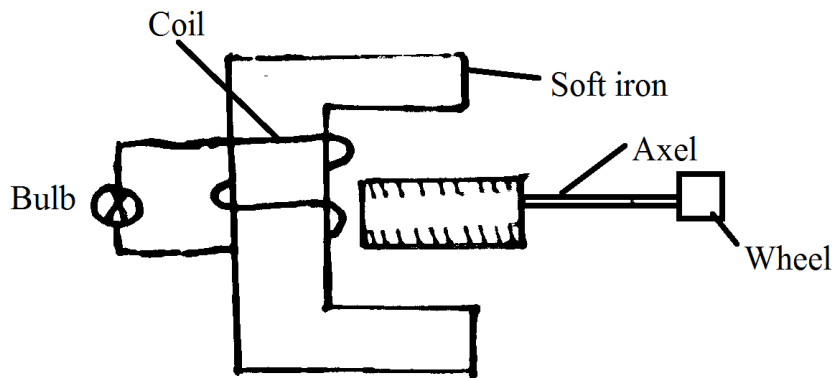

i) Explain why the bulb light (2 mks)

.....  
.....  
.....

ii) How can the bulb be made brighter. (2 mks)

.....  
.....  
.....

11. (a) What is meant by radio-active decay? (2 mks)

.....  
.....  
.....

(b) Half life of a certain radioactive element is 16 years.

(i) What fraction of the element will be remaining after 48 years? (2 mks)

.....  
.....  
.....

(ii) What fraction of the element will have decayed after 64 years? (2 mks)

(c) The following data was obtained from the reading of a counter connected to Geiger Muller tube placed in front of a radioactive source.

Time in minutes	0	4	8	12	16
Count rate per minutes	800	520	345	225	145

From the table above;

(i) Plot the graph of count-rate (per minute) against time (minutes) (2 mks)

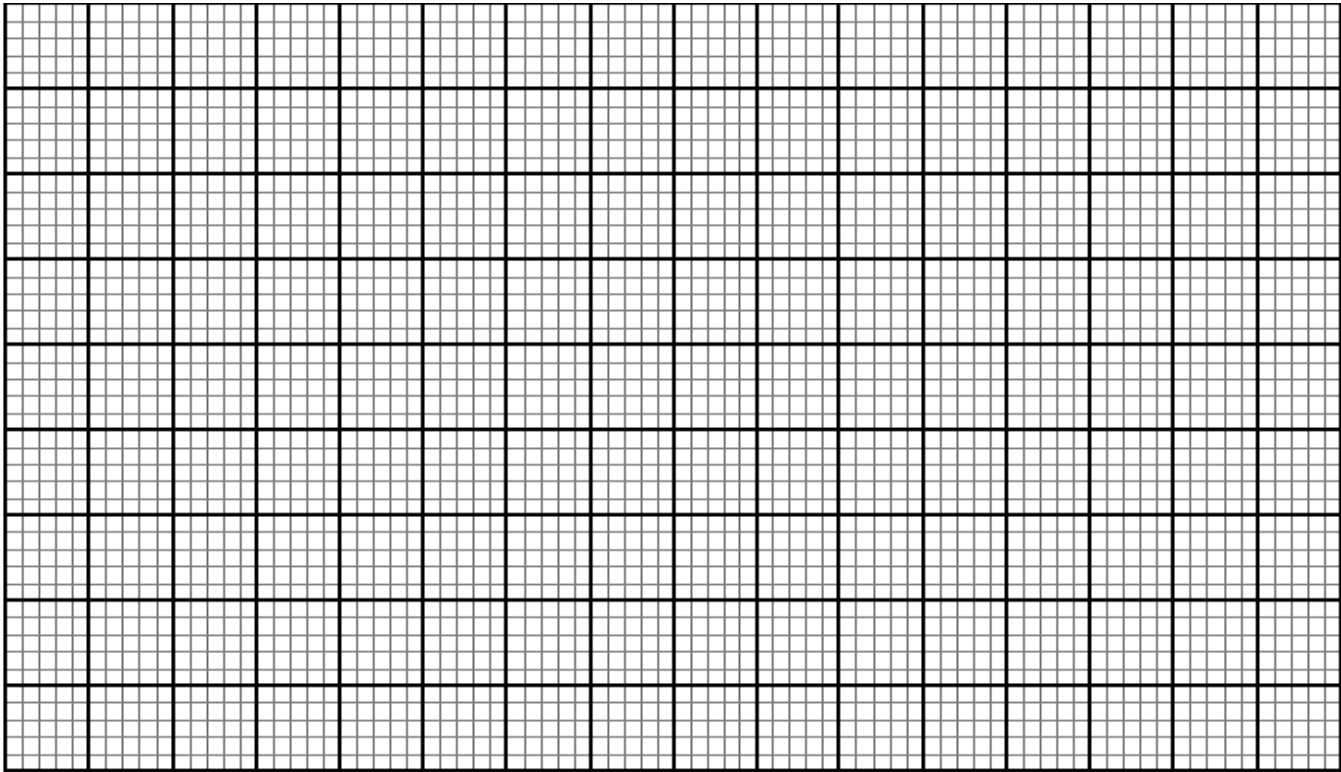

(ii) Determine the half-life of the radioactive source (1 mk)

(iii) Explain the nature of the graph. (2 mks)

.....  
.....

.....  
.....

12. (i) Explain how P-type semi-conductor is formed. (2 mks)

.....  
.....  
.....

(ii) Explain the nature of the graph. (2 mks)

.....  
.....  
.....

12. (i) Explain how P-type semi-conductor is formed. (2 mks)

.....  
.....

(ii) Distinguish between intrinsic and extrinsic semi conductors (2 mks)

.....  
.....  
.....

(iii) The figure below shows a circuit with two diodes P and Q and a cell.

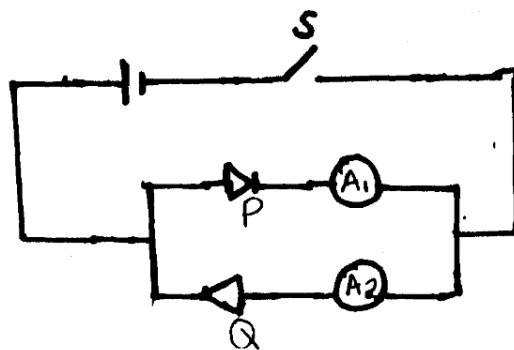

Explain the observation which would be made if S is closed. (2 mks)

.....  
.....  
.....

13. (a) The diagram below shows simplified diagram of an x-ray tube.

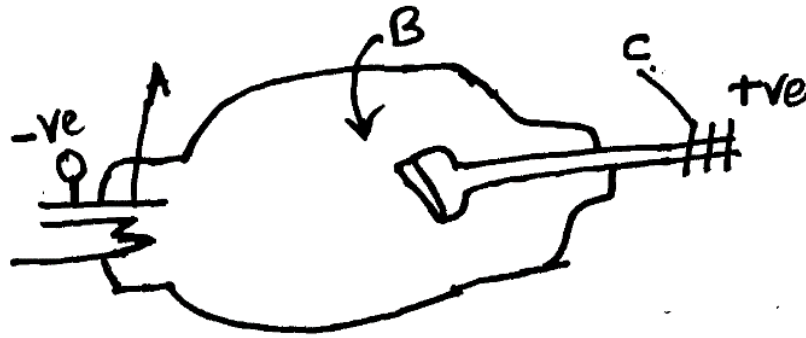

(i) Name parts A, B and C.

.....  
.....

(ii) What adjustments would be made to

a) Increase the penetrating power of the X-ray produced (1 mks)

.....  
.....

b) Increase the intensity of the rays produces (1 mk)

.....  
.....

(iii) Name a suitable material for the part marked B and give a reason for your choice. (2 mks)

.....  
.....  
.....

(iv) Name a suitable material for the part marked C and state its purpose (2 mks)

.....  
.....  
.....

(v) Why is it necessary to maintain a vacuum inside the tube? (2 mks)

.....  
.....  
.....

(vi) State one use of X-rays in the following areas. (2 mks)

a) Medicine

.....  
.....

b) In industry

.....

- (b) (i) State two factors which would affect the resistance of a metal conductor other than the temperature. (2 mks)

.....

.....

.....

- (ii) Define potential difference and state in SI units (1mk)

.....

.....

- (iii) In the following configuration of resistors, determine the current through the  $5\Omega$  resistor. (2 mks)

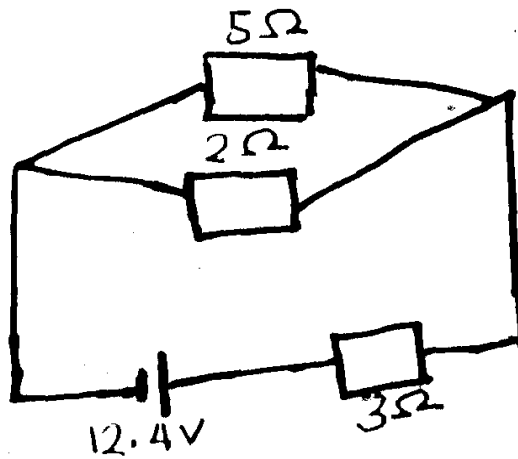

# FORM 4 ENDTERM 2 EXAMS

## PHYSICS

### PAPER 2

TIME:2 HOURS

NAME..... ADM NO:.....

SIGN..... DATE;.....

#### INSTRUCTIONS TO CANDIDATES

1. Write your name and index number in the spaces provided
2. Sign and write the date of examination in the spaces provided
3. This paper consists of **TWO** sections A and B
4. Answer **ALL** questions in the spaces provided
5. Mathematical table and electronic calculators may be used.
6. **ALL** working **MUST** be shown clearly where necessary.  
*Take: acceleration due to gravity  $g = 10\text{ms}^2$*

#### FOR OFFICIAL USE ONLY

SECTION	QUESTION	MAXIMUM SCORE	CANDIDATE'S SCORES
A	1 - 12	25	
B	13	11	
	14	12	
	15	12	
	16	16	
	17	11	
		<b>TOTAL SCORE</b>	80

1. (i) Name the error that arises from not reading the metre rule normally. (1 mk)

.....

(ii) Name the instrument suitable for measuring the following;

(a) Thickness of your hair (1 mk)

.....

b) Diameter of a marble of 3.65 cm (1mk)

.....

2. The figure below is a uniform metre rule pivoted near the end. It is kept in equilibrium by spring balance.

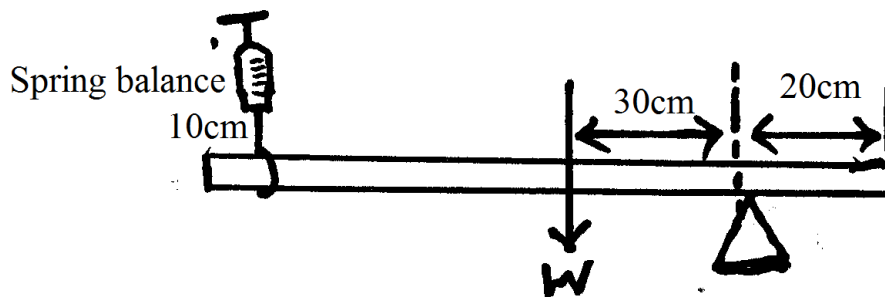

If the reading indicated by the spring balance is 1.2N determine the weight of the metre rule.

(2 mks)

3. Name two forces acting on bodies which are not in contact. (2 mks)

.....  
.....

4. (a) Define force and state its SI units (2 mks)

.....  
.....

(b) The figure below shows water drops on two surfaces. In (a) the glass surface is smeared with wax while in (b), glass surface is clean.

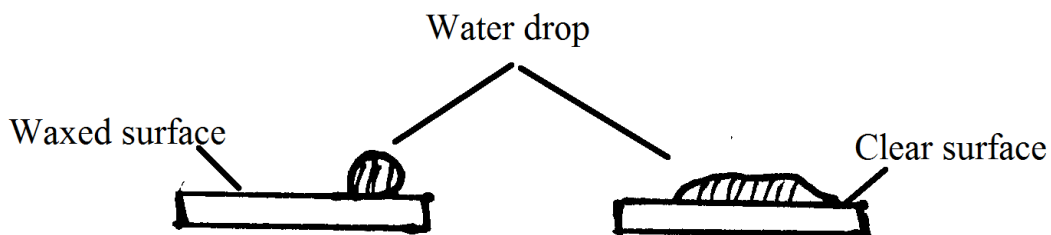

Explain the difference in the shape of the drops. (2 mks)

.....

.....  
.....

(c) The weight of a stone on the earth's surface is 6.5N. Calculate the weight of the same stone on another planet where  $g=6\text{N/kg}$ . (Take  $g$  from the earth to be  $10\text{N/kg}$ ) (2 mks)

5. (a) Explain why in uniform circular motion, even though the speed is constant the bodies will undergo acceleration. (2 mks)

.....  
.....  
.....  
.....

(b) The figure below shows a body of mass 1 kg in a circle.

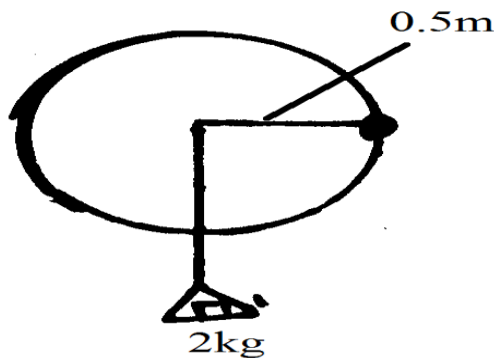

Calculate the angular velocity of the body if the body experienced a friction of 2N on the surface as it moves. (3 mks)

6. The diagram below shows water with negligible viscosity flowing steadily in a tube of different cross sectional area. If at point A the cross sectional area is  $120\text{cm}^3$  and the velocity of water is  $0.40\text{m/s}$ , calculate the velocity at B where the cross sectional area is  $4.0\text{cm}^2$  (2 mks)



7. (a) When observed through in microscope pollen grains particles in water move about irregularly. Explain this observation. (2 mks)

.....  
 .....  
 .....

(b) A bottle containing ammonia solution is placed at the back of the laboratory. Give a reason why its smell may not be detected in other parts of the laboratory if the temperature of the solution is kept very low. (2 mks)

.....  
 .....  
 .....

8. Figure below shows a water sprinkler in action.

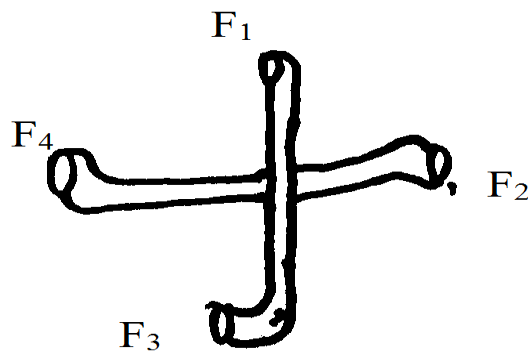

Name any pair of forces that constitute a couple. (1 mk)

.....  
 .....

**SECTION B**

9. (a) A trolley of mass 0.5kg moving with a velocity of 1.2m/s collides with a second trolley of mass 1.5 moving in the same direction with a velocity of 0.2m/s

(i) What is an inelastic collision. (2 mks)

.....  
 .....

(ii) Determine the velocity of the trolley after collision. (2 mks)

(b) (i) Define impulse in terms of momentum. (1 mk)

.....  
.....

(ii) For a particle of mass  $m$  on which is initially moving vertically downwards with velocity  $u$ , obtain an experiment for changes in kinetic energy after  
a) it has moved under gravity for time  $t$ . (2 mks)

.....  
.....  
.....

b) It has moved freely under gravity for a vertical  $h$ . (2 mks)

.....  
.....  
.....

(c) A lead ball is placed on the surface of viscous oil and released.

(i) State three forces acting on the ball as it fall through the oil. (3 mks)

.....  
.....  
.....

(ii) State which forces vary during the fall and explain the reason for the variation. (1 mk)

.....

(iii) What is meant by the term terminal velocity of the ball. (1 mk)

.....  
.....

(iv) Sketch a graph showing the variation of the displacement of the ball with time from the time it was released. (1 mk)

10. (a) An object weighs 2.6N in air and 2.2N when completely immersed in water. Determine the relative density of the object. (2 mks)

- (b) When a stone is placed on water, it sinks but when the same stone is placed in a block of wood, both are found to float Explain this observation. **(2 mks)**

.....

.....

.....

- (c) The figure below shows a rectangular block of height 10cm floating vertically in a beaker containing 2 immiscible liquids. A and B of densities  $800\text{kg/m}^3$  respectively. The block is 3cm long by 2cm wide by 10cm high.

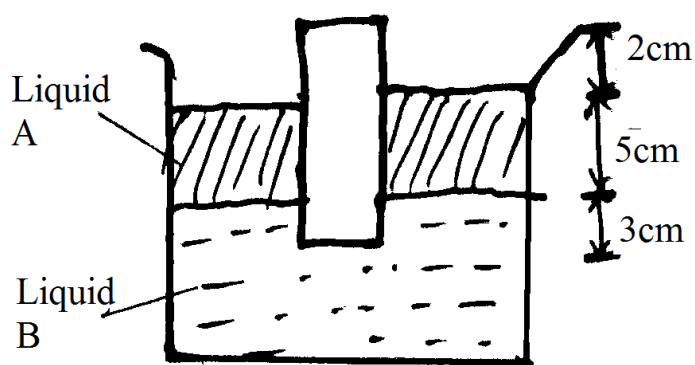

If the length of the block in liquid A is 3cm and that in B is 5cm, determine;

- (i) Weight of the liquid A displaced. **(3 mks)**

- (ii) Weight of the liquid B displaced. **(3 mks)**

11. (a) The figure below shows a wire with weight attached to the end and passed over a block of ice.

It is observed that the wire cuts through the block remains as one piece. **(3 mks)**

- (b) An unknown mass of water and 400g of alcohol were heated separately each of them by a heater rated 220V, 2.5A. Temperature of both liquids were taken and recorded at some intervals. The graphs OMN and OBC show variation of temp with time for alcohol and water respectively.

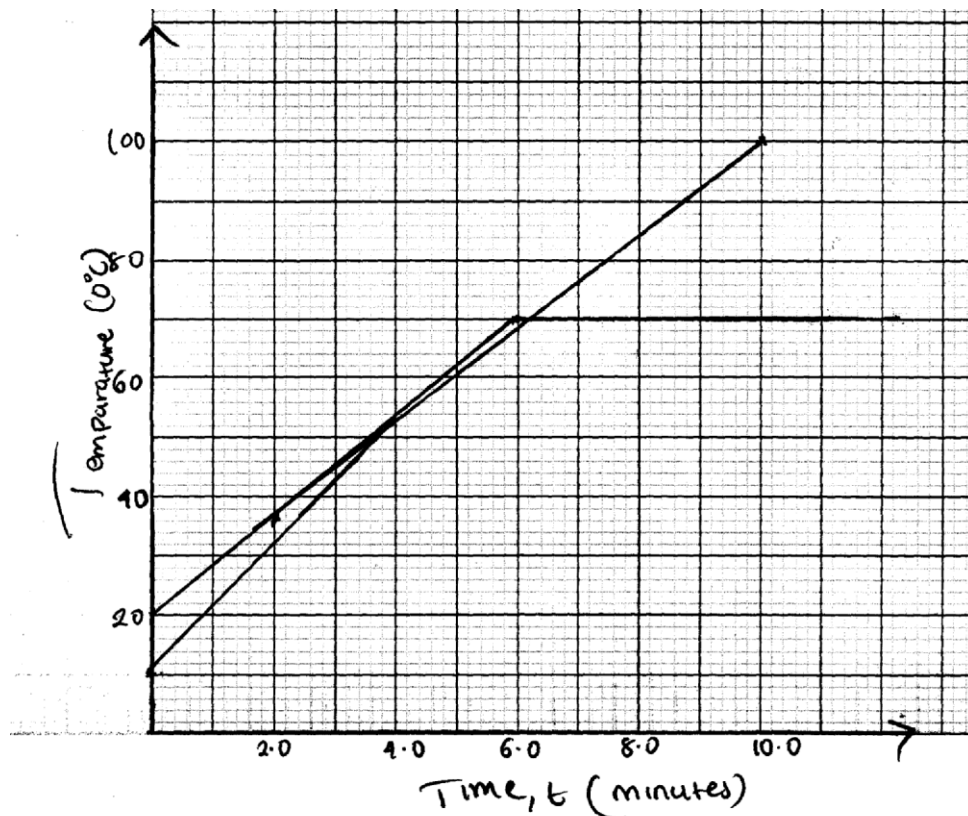

- i) State what is observed on alcohol after the sixth minute (1 mk)

.....  
 .....

- ii) Explain why there is no temperature change in alcohol after 5 minutes. (2 mks)

.....  
 .....

- (c) (i) Determine the amount of heat energy required to raise the temperature of water from 36°C to 88°C .

- (ii) Determine the mass of water used in this experiment. Take specific heat capacity of water to be 4200Jk<sup>-1</sup>gk<sup>-1</sup> (3 mks)

12. (i) Name one machine whose velocity ratio is less than one. (1 mks)

.....  
.....

(ii) State one reason why the efficiency of a machine is always less than 100% (1 mks)

.....  
.....

(iii) Sketch a graph of efficiency against mechanical advantages (M.A) (2 mks)

.....  
.....  
.....  
.....  
.....

(iv) The diagram in the figure below shows a wheel and axle used as a machine, whose efficiency is 80% to raise 400N of building materials. The wheel and axle have diameters of 75cm and 15cm respectively.

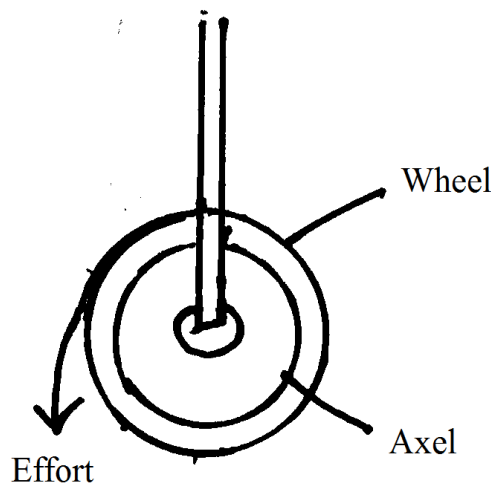

(v) Mark on the diagram the correct position and direction of the load to be lifted. (2 mks)

(b) Name the principle on which this machine works. (1 mk)

.....

(c) Calculate the effort needed to raise the load. (3 mks)

13. (i) It is observed that when a bubble rises from the bottom of a glass filled with water to the top in size increases. Explain the observation. **(2 mks)**

.....  
.....  
.....

- (ii) A ballon is filled with air to a volume of 200ml at a temperature of 293K. Determine the volume when the temperature rises to 353K at the same pressure. **(2 mks)**

- (iii) Differentiate between an ideal gas and real gas. **(1 mk)**

.....  
.....  
.....

- (iv) Using a well-labeled diagram, describe an experiment to verify Charles's law. **(3 mks)**

# FORM 4 ENDTERM 2 EXAMS

# AGRICULTURE

## PAPER 1

TIME:2 HOURS

NAME..... ADM NO:.....

SIGN..... DATE;.....

### INSTRUCTIONS TO CANDIDATES.

- Write your name and Index number in the spaces provided above.
- This paper has three sections A, B and C.
- Answer **ALL** question in section A and B
- Answer any **TWO** questions in section C in the spaces provided.

### FOR EXAMINERS USE ONLY.

SECTION	QUESTION	MAX. SCORE	CANDIDATES SCORE
A	1-16	30	
B	17-19	20	
C	20-22	40	
TOTAL SCORE		90	

## SECTION A (30marks)

Answer ALL questions in this section in the spaces provided

1. Give four aspects of rainfall that affect agricultural production. (2mks)

.....  
.....  
.....  
.....  
.....

2. State 4 factors considered when choosing water pipes for use in the farm. (2mks)

.....  
.....  
.....  
.....  
.....

3. List down 4 types of water erosion. (2mks)

.....  
.....  
.....  
.....  
.....

4. Give three classes of weeds on the basis of growth cycle. (1½mks)

.....  
.....  
.....  
.....  
.....

5. Define the term pest. (1mk)

.....  
.....

6. State 4 reasons why burning of bushes is discouraged as a method of land clearing. (2mks)

.....  
.....  
.....  
.....  
.....

7. Outline 4 factors considered when grading tomatoes. (2mks)



.....  
.....  
.....  
.....  
.....

**8.** List down four environmental factors that affect crop production. **(2mks)**

.....  
.....  
.....  
.....  
.....

**9.** Give 3 maintenance practices carried out on water tanks. **(1 ½ mks)**

.....  
.....  
.....  
.....

**10.** Give four importance of soil to crops. **(2mks)**

.....  
.....  
.....  
.....  
.....

**11.** What 4 factors determine the use of a jembe instead of a disk plough. **(2mks)**

.....  
.....  
.....  
.....  
.....

**12.** Define the following terms. **(2 ½ mks)**

(i) Seedling bed

.....  
.....

(ii) Nursery bed

.....  
.....

(iii) Seed bed

.....  
.....  
(iv) Pricking out  
.....  
.....

(v) Hardening off  
.....  
.....

13. List down four factors of production. (2mks)  
.....  
.....  
.....  
.....

14. Name the parts harvested for each of the following crops.  
(a) Onions  
.....  
(b) Carrots  
.....  
(c) Coffee  
.....

15. Name four main methods of controlling pests in the farm. (2mks)  
.....  
.....  
.....  
.....

16. Mention 3 ways of applying water to crops in overhead irrigation. (3mks)  
.....  
.....  
.....  
.....

## SECTION B (20MRKS)

Answer ALL the questions in this section in the spaces provided

17. Study the illustration below of a tea vegetative material and answer the questions that follow.

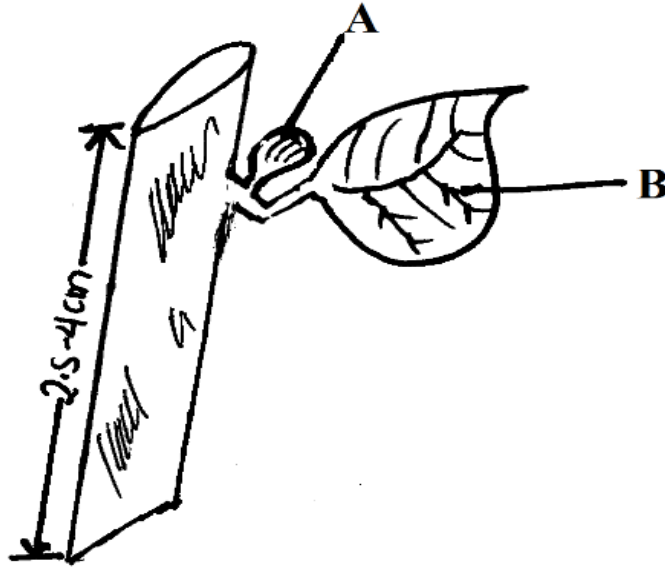

(a) Name the part labeled A & B. (2mks)

A

.....

B

.....

(b) State any three desirable characteristics of the selected parts use to develop the planting material illustrated above. (3mks)

.....  
 .....  
 .....

(c) State any two precautions observed during preparations of the material illustrated above before planting. (2mks)

.....  
 .....

18. Study the illustration below of making compost manure and answer the questions that follow.

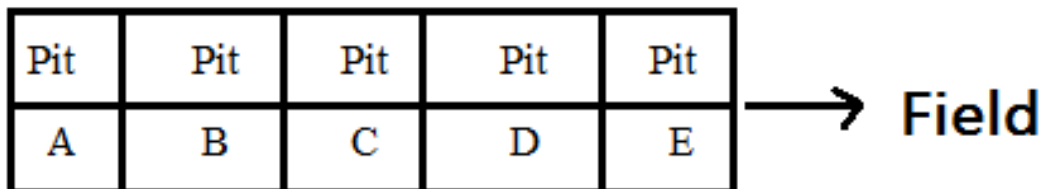

(a) Name the method of making compost manure illustrated above. **(1mk)**

.....

(b) Name the other method of making compost manure. **(1mk)**

.....

(c) State 4 qualities of well decomposed compost manure. **(4mks)**

.....

.....

.....

.....

19. The diagram below is an illustration of soil erosion caused by water. Study it carefully and answer the questions that follow.

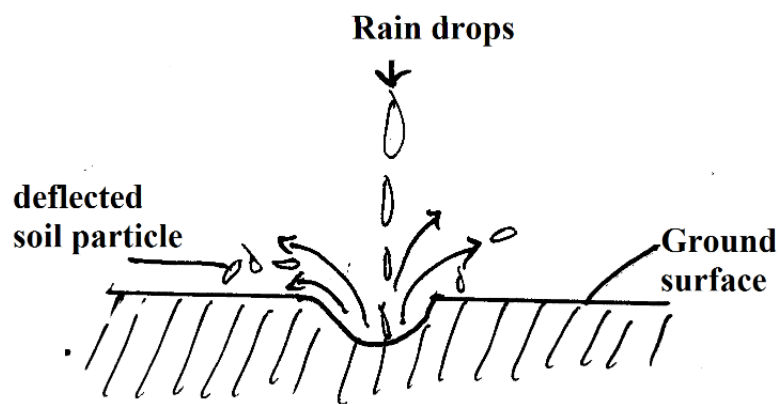

(a) Identify the method of soil erosion caused by water illustrated above. **(1mk)**

.....

(b) Name other three types of soil erosion caused by water. **(3mks)**

.....

.....

.....

(c) Define the term soil erosion. **(1mk)**

.....

.....

(d) List down 2 agents of soil erosion. **(2mks)**

.....

.....

## SECTION C (40MARKS)

***Answer only TWO questions in this section in the spaces provided***

20. (a) Explain 8 factors that can encourage soil erosion. **(8mks)**
- (b) Outline any five activities that may be undertaken in organic farming. **(5mks)**
- (c) Outline 7 ways in which temperature affects agricultural production in Kenya. **(7mks)**
21. (a) Explain 7 factors that influence seed rate in crop production. **(7mks)**
- (b) Outline 7 safety precautions observed when using herbicide in the farm. **(7mks)**
- (c) Explain briefly any six factors that affect the quality of hay a farmer may produce in the farm. **(6mks)**
22. (a) Outline 10 importance of farm records. **(10mks)**
- (b) Explain 5 factors that should be considered in farm planning. **(10mks)**

.....

.....

.....

.....

.....

.....

.....

.....

.....

.....

.....

.....

.....

.....

.....

.....

.....

.....

.....

.....

.....

.....

.....

.....

.....

.....



.....  
.....  
.....  
.....  
.....  
.....  
.....  
.....  
.....  
.....  
.....  
.....  
.....  
.....  
.....  
.....  
.....  
.....  
.....  
.....  
.....  
.....  
.....  
.....  
.....  
.....  
.....  
.....  
.....  
.....  
.....  
.....  
.....  
.....  
.....  
.....  
.....  
.....  
.....  
.....  
.....  
.....  
.....  
.....  
.....  
.....  
.....  
.....  
.....  
.....  
.....  
.....  
.....  
.....  
.....  
.....  
.....  
.....





# FORM 4 ENDTERM 2 EXAMS

## AGRICULTURE

### PAPER 2

TIME:2 HOURS

NAME..... ADM NO:.....

SIGN..... DATE;.....

443/2

## AGRICULTURE

### PAPER2

TIME: 2 HOURS

#### INSTRUCTIONS TO CANDIDATES.

- Write your name and Index number in the spaces provided above.
- This paper has three sections A, B and C.
- Answer **ALL** question in section A and B
- Answer any **TWO** questions in section C in the spaces provided.

#### FOR EXAMINERS USE ONLY.

SECTION	QUESTION	MAX. SCORE	CANDIDATES SCORE
A	1-17	30	
B	18-20	20	
C	21-23	40	
TOTAL SCORE		90	

**FOR MARKING SCHEMES CALL/WHATSAPP 0746 222 000**

# SECTION A (30marks)

Answer ALL questions in this section in the spaces provided

1. State four ways of controlling lice in poultry. (2mks)  
.....  
.....  
.....  
.....
2. State three signs of heat observed in rabbits. (1 ½ mks)  
.....  
.....  
.....
3. Give three uses of a jack plane. (1 ½ mks)  
.....  
.....  
.....
4. Outline three methods of extracting honey from honey combs. (1 ½ mks)  
.....  
.....  
.....
5. State four signs of broodiness in a hen. (2mks)  
.....  
.....  
.....  
.....
6. Outline four methods of docking used in sheep rearing. (2mks)  
.....  
.....  
.....  
.....
7. Name any four parts of a building that can be reinforced using concrete. (2mks)  
.....  
.....  
.....
8. Give two reasons why a farmer prefers single housing for the calves in the farm. (1mk)  
.....  
.....  
.....
9. Give two hormones responsible for milk let down. (1mk)  
.....  
.....
10. State four physiological body processes considered when assessing an animal's health. (2mks)

**FOR MARKING SCHEMES CALL/WHATSAPP 0746 222 000**

.....  
.....  
.....

11. Outline four structures used to control livestock parasites. (2mks)

.....  
.....  
.....

12. Give five factors farmer must consider when sitting an apiary. (2 1/2 mks)

.....  
.....  
.....

13. State one use for each of the following.

(i) Spoke shave (1mk)

.....  
.....

(ii) Plumb bob (1mk)

.....  
.....

14. State four physical characteristics of beef cattle. (2mks)

.....  
.....  
.....

15. State four causes of infertility in dairy cattle.

.....  
.....  
.....

16. Give three roles of the livestock industry in Kenyan economy. (1 1/2 mks)

.....  
.....  
.....

17. State three factors that would affect the digestibility of food in livestock nutrition. (1 1/2 mks)

.....  
.....  
.....

**SECTION B (20MRKS)**

**Answer ALL the questions in this section in the spaces provided**

18. Study the illustration below and answer the questions that follow.

**FOR MARKING SCHEMES CALL/WHATSAPP 0746 222 000**

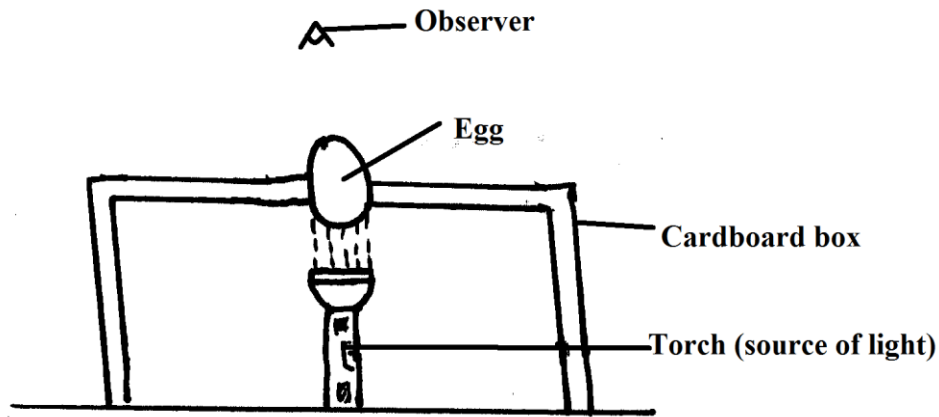

- (a) Identify the practice. (1mk)  
.....
- (b) Give one reason for carrying out the above practice. (1mk)  
.....  
.....
- (c) State four characteristics of eggs selected for incubation. (4mks)  
.....  
.....  
.....  
.....
- (d) State two disadvantages of natural incubation. (2mks)  
.....  
.....  
.....

19. Study the tool illustrated below and answer the questions that follow.

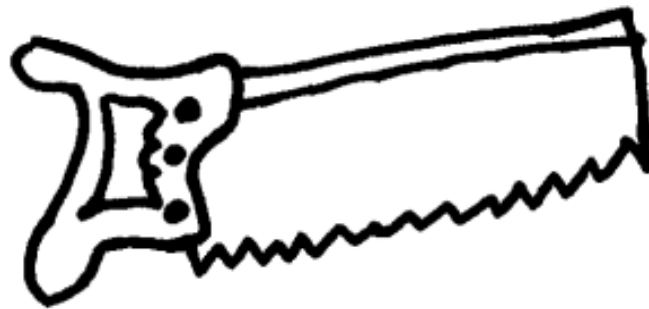

- (a) Identify the tool (1mk)  
.....
- (b) State one safety measure when using the tool. (1mk)  
.....
- (c) State two ways of maintaining the tool above. (2mks)  
.....  
.....

20. The diagram below represents a foundation of a farm structure. Study it and answer the questions that follow.

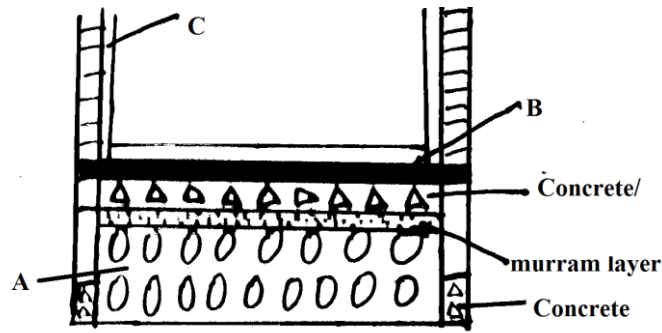

(a) Identify the part labeled A and B. (2mks)

.....  
 .....

(b) State two uses of part labeled B in a foundation structure. (4mks)

.....  
 .....

(c) What ingredients are used to complete part C. (2mks)

.....  
 .....

**SECTION C (40MARKS)**

**Answer only TWO questions in this section in the spaces provided**

- 21.** (a) Describe the artificial rearing of a day old layer chick to the end of brooding. (10mks)  
 (b) Explain factors that influence the quality of milk. (6mks)  
 (c) Give four structural requirements of a good calf pen. (4mks)

- 22.** (a) Outline five factors to consider while culling dairy cattle. (10mks)  
 (b) State five advantages of live fence. (10mks)

- 23.** (a) State five reasons for maintaining farm tools and equipments. (10mks)  
 (b) State four characteristics of effective acaricides. (4mks)  
 (c) Describe the feeding of fish in a fish pond. (6mks)

.....  
 .....











# FORM 4 ENDTERM 2 EXAMS

## BUSINESS STUDIES

### PAPER 1

TIME:2 HOURS

NAME..... ADM NO:.....

SIGN..... DATE;.....

565/1

## BUSINESS STUDIES

### PAPER 1

TIME: 2HRS

**INSTRUCTIONS TO CANDIDATES.**

- i) Write your name and index number
- ii) Answer all the question in the spaces provided
- iii) All the questions must be written in the spaces provided in the booklet
- iv) Candidates should answer the questions in English.

**FOR EXAMINERS USE ONLY**

Question	1	2	3	4	5	6	7	8	9	10	11	12
Candidate`s Score												

Question	13	14	15	16	17	18	19	20	21	22	23	24	25
Candidate`s Score													

Total marks

1. Outline four measures that can be undertaken by consumers to satisfy his/her needs. (4marks)

- a).....
- b) .....
- c) .....
- d) .....

2. State four factors that an entrepreneur would consider when determining business viability. (4mks)

- a).....
- b) .....
- c) .....
- d) .....

3. Highlight four reasons why commercial banks may refuse to make payment against a cheque. (4mks)

- a).....
- b) .....
- c) .....
- d) .....

4. State three advantages enjoyed by a business person who sells his/her goods through hire purchase. (3mks)

- a).....
- b) .....
- c) .....
- d) .....

5. Outline four reasons why a modern producer would prefer indirect production over direct production. (4mks)

- a).....
- b) .....
- c) .....
- d) .....

6. Classify each of the following activities into its appropriate level of production. (4mks)

ACTIVITY	Level of production
(a). Putting up the standard gauge railway from Nairobi to Mombasa	
(b). Making iron sheets and tiles for roofing houses	
(c). Mining Titanium in Kwale Mombasa county	
(d). Buying processed tea from Mucii Mukuru factory for sale to consumers.	

7. Highlight four roles played by the information communication technology in office management.

(4mks)

- a).....
- b) .....
- c) .....
- d) .....

8. The following statements refers to office machines. State the machine being referred to in each case. (4mks)

- (a) Used for destroying unwanted documents by cutting them into small thin pieces in order to avoid them getting into wrong hands. \_\_\_\_\_
- (b) It is mainly used for putting stamp impressions on envelopes. \_\_\_\_\_
- (c) It is mainly used for making uniform holes on paper for filing. \_\_\_\_\_
- (d) It is mainly used for recording dictated messages where accuracy is required.  
\_\_\_\_\_

9. State any four advantages of transporting oil products by pipeline instead of roads. (4mks)

- a).....
- b) .....
- c) .....
- d) .....

10. State four reasons why a business plan is important to a potential investor. (4mks)

- a).....
- b) .....
- c) .....
- d) .....

11. Highlight three factors a business man should consider before extending credit facilities to a customer. (3mks)

- a).....
- b) .....
- c) .....
- d) .....

12. State four benefits that an insured would get out of pooling of risks in insurance. (4mks)

- a).....
- b) .....
- c) .....
- d) .....

13. Outline four challenges that a company encounters when using sales personnel to market their products. (4mks)

- a).....
- b).....
- c).....
- d).....

14.

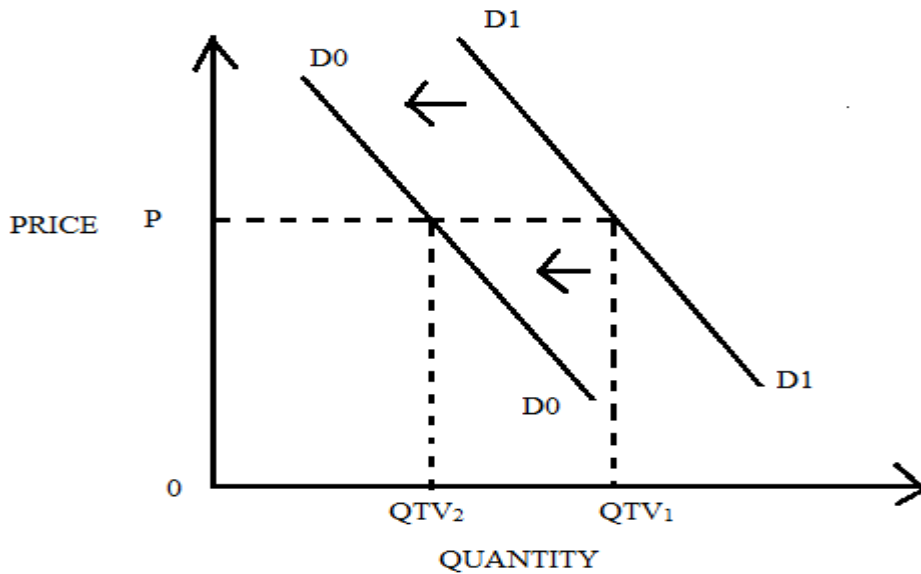

State four causes of movement of demand curve in the above diagram from D<sub>1</sub>D<sub>1</sub> to D<sub>0</sub>D<sub>0</sub>.(4mks)

- a).....
- b).....
- c).....
- d).....

15. State four characteristics of money. (4mks)

- a).....
- b).....
- c).....
- d).....

16. The following balance sheet relate to Mikinduri Traders.

Mikinduri Traders			
Balance sheet as at 1/1/2016			
	Shs		Shs
Premises	100,000	Capital	120,000
Stock	70,000	Creditors	45,000
Bank	50,000	Bank loan	335,000
Motor vehicles	220,000		
Debtors	60,000		
	500,000		500,000
	500,000		500,000

The following transactions took place during the month of January 2016.

**FOR MARKING SCHEMES CALL/WHATSAPP 0746 222 000**

- (1) Paid creditors shs 5000 by cheque
- (2) Received cash from debtors shs 30,000
- (3) Took goods worth shs 10,00 for personal use.

Required: Prepare the balance sheet of Mikinduri Traders as at 31/1/2016.

**(5mks)**

- 17.** Post the following transactions in the relevant ledger accounts, balance the accounts and extract a trial balance as at 30/6/2016. **(5mks)**

June 1: Balance brought forward cash shs 8,000

June 15: Bought stock worth shs 2,000 cash.

18. The following balances were extracted from the books of Rware Traders for the year ended 31/12/2017.

	shs
Opening stock	75,000
Profit margin	25%
Sales	400,000
Closing stock	20,000

Required: Prepare Rware Traders Trading account.

(4mks)

19. Meru Traders had the following balances on 31/12/2013

	Shs
Machines	200,000
Creditors	80,000
Capital	210,000
Debtors	10,000
Stock	40,000
Cash	60,000
Salaries owing	40,000
Prepaid rent	20,000

Required: Prepare the opening entries in the general journal as 1/1/14.

(4mks)

20. State four drawbacks faced by traders engaging in Barter trade. (4mks)

- a).....
- b) .....
- c) .....
- d) .....

21. Outline four reasons why government of Kenya impose taxes on its citizens. (4mks)

- a).....
- b) .....
- c) .....
- d) .....

22. Highlight four problems encountered in calculating the consumer price indices. (4mks)

- a).....
- b) .....
- c) .....
- d) .....

23. State four measures taken by the government of Kenya to control the importation of sugar into the country. (4mks)

- a).....
- b) .....
- c) .....
- d) .....

24. State four features of under development. (4mks)

- a).....
- b) .....
- c) .....
- d) .....

25. Indicate whether the following refer to injections or withdrawals in the circular flow of National income. (4mks)

- a) Savings .....
- b) Taxes .....
- c) Government spending .....
- d) Exports .....



# FORM 4 ENDTERM 2 EXAMS

## BUSINESS STUDIES

### PAPER 2

TIME:2 ½ HOURS

NAME..... ADM NO:.....

SIGN..... DATE;.....

### INSTRUCTION TO CANDIDATES.

- Write your **name** and **index number** on the answer booklet provided.
- This paper consists of **six** questions.
- Answer **any five** questions.
- All questions carry equal marks.

### QUESTIONS

1. (a) Explain any FIVE reasons as to why a higher per capita income is not necessarily an indicator of higher standard of living. (10mks)
  - (b) Outline any FIVE reasons for popularity of motorcycles (boda bodas) as a means of transport. (10mks)
2. (a) Despite advantages of large-scale businesses, small businesses continue to exist long large-scale businesses. Explain any FIVE reasons for popularity of small businesses. (10mks)
  - (b) Explain FIVE modern trends in office management. (10mks)
3. (a) Outline any FIVE functions of the stock exchange market. (10mks)
  - (b) Explain any FIVE reasons for higher birthrate in developing countries. (10mks)
4. (a) Explain any FIVE reasons as to why indirect taxes may be preferred to direct taxes as a source of government income. (10mks)
  - (b) Highlight any FIVE circumstances under which direct selling of goods to consumers is appropriate. (10mks)

5. (a) Explain FIVE circumstances under which an insurance company would not compensate the insured in the event of loss. **(10mks)**
- (b) Highlight any FIVE benefits that a wholesaler would get by operating a warehouse. **(10mks)**
6. (a) Explain any FIVE characteristics of human wants. **(10mks)**
- (b) The following transactions relate to Opiyo traders for the month of Jan 2015.
- i) On Jan 1<sup>st</sup> started a business with 100,000 which he deposited in business bank account.
  - ii) On Jan 3<sup>rd</sup> he bought a piece of (10,000) land and paid through a cheque.
  - iii) On Jan 5<sup>th</sup> he bought more 50,000 into the business inform of cash from his personal savings.
  - iv) On Jan 10<sup>th</sup> he bought goods for 10,000 from Rashid traders on credit
  - v) On Jan 14<sup>th</sup> he sold goods to Onyango traders for 8,000 on credit
  - vi) On Jan 18<sup>th</sup> he paid 5,000 inform of a cheque being salaries
  - vii) On Jan 25<sup>th</sup> he received 25,000 in cash being a commission.
  - viii) On Jan 28<sup>th</sup> Onyango paid 6,000 in cash
  - ix) On Jan 30<sup>th</sup> he withdrew 20,000 from his business bank account i.e. 5,000 for office use and 15,000 for personal use.

**Required:-**

- i) Open all the ledger accounts and record the above transactions.
- ii) Balance up the accounts and extract a trial balance as at 31<sup>st</sup> Jan 2015. **(10mks)**

# FORM 4 ENDTERM 2 EXAMS

## CHRISTIAN RELIGIOUS EDUCATION

### PAPER 1

TIME:2 ½ HOURS

NAME..... ADM NO:.....

SIGN..... DATE;.....

#### Instructions to candidates

- (a) This paper consists of six questions.
- (b) Answer **any five** questions in the answer booklet provided.
- (c) Each question carries 20 marks.
- (d) Candidates should check the question paper to ascertain that all pages are printed as indicated and that no questions are missing.
- (e) Candidates should answer the questions in English.

#### FOR EXAMINER'S USE ONLY.

QUESTION NO.	1	2	3	4	5	6
MARKS						

GRAND TOTAL

#### QUESTIONS

**FOR MARKING SCHEMES CALL/WHATSAPP 0746 222 000**

1. (a) Identify **six** deuterocanonical books found in the Catholic bible. **(6 marks)**  
(b) Give **six** reasons why Christians use the bible in worship. **(6 marks)**  
(c) With reference to the creation stories, state eight teachings on the relationship between human beings and God. **(8 marks)**
2. (a) With reference to Genesis 12 : 1 – 9, outline **seven** promises given to Abraham by God at the time of his call. **(7 marks)**  
(b) Identify **seven** events that took place during the Passover night. **(7 marks)**  
(c) Mention **six** lessons that Christians can learn from the incident when Abraham was willing to sacrifice his son Isaac. **(6 marks)**
3. (a) Outline **six** roles played by Prophet Samuel in Israel. **(6 marks)**  
(b) Explain how King Ahab contributed to the spread of idolatry in Israel. **(7 marks)**  
(c) Identify **seven** ways in which the church supports political leaders in Kenya. **(7 marks)**
4. (a) Outline **four** differences between the Old Testament and Traditional African prophets. **(8 marks)**  
(b) Describe the religious background to the call of prophet Amos. **(6 marks)**  
(c) Give **six** ways in which Christians are preparing for the day of the Lord today. **(6 marks)**
5. (a) With reference to the teachings of Jeremiah, describe how the Israelites were encouraged to live in hope during Babylonian exile. **(7 marks)**  
(b) Give **seven** problems that Nehemiah encountered in the rebuilding of the wall of Jerusalem. **(7 marks)**  
(c) Outline **six** ways in which Christians resolve conflicts among themselves. **(6 marks)**
6. (a) Give **seven** ways in which traditional African communities show respect for the unborn child. **(7 marks)**  
(b) Outline **seven** moral values acquired during marriage in traditional African communities. **(7 marks)**  
(c) State **six** responsibilities of priests in traditional African communities. **(6 marks)**

# FORM 4 ENDTERM 2 EXAMS

## CHRISTIAN RELIGIOUS EDUCATION

### PAPER 2

TIME:2 ½ HOURS

NAME..... ADM NO:.....

SIGN..... DATE;.....

#### INSTRUCTIONS TO CANDIDATES:

- *This paper consists of SIX questions.*
- *Answer any FIVE questions from this paper in the answer booklet provided.*
- *Each question is 20 marks.*
- *This paper consists of 2 printed pages.*
- *Candidates should check the question paper to ascertain that both pages are printed as indicated and that no questions are missing*

1. (a) Outline Nathan's prophecy about the Messiah ( 2 Samuel 7 :3-17). (7 mks)  
(b) Describe the events that took place the night Jesus was born ( Luke 2:1-19) (7 mks)  
(c) State the lessons Christians learn from Zechariah's song, the Benedictus. (6 mks)
  
2. (a) Relate the healing of the Centurion servant ( Luke 7:1-10) (7 mks)  
(b) Outline seven ways used by Jesus to demonstrate His concern for the needy in Galilee. (7 mks)  
(c) Show how the church continues with the healing ministry of Jesus Christ. (6 mks)
  
3. (a) What instructions did Jesus give to the seventy apostles during the commissioning ( Luke 10:1-24) (7 mks)  
(b) Explain five areas of conflict between Jesus and the Jewish leaders that eventually led to His death. (5 mks)  
(c) State the importance of prayer in Christian life today. (8 mks)
  
4. (a) Highlight seven spiritual gifts as taught by St.Paul in the early church. (7 mks)  
(b) Explain how the unity of believers is expressed as "the body of Christ" in the New Testament. (5 mks)  
(c) How are the gifts of the Holy Spirit manifested in the church today. (8 mks)
  
5. (a) State six forms of irresponsible sexual behavior. (6 mks)  
(b) Explain the importance of the extended family. (7 mks)  
(c) Outline seven challenges related to family life today. (7 mks)
  
6. (a) Give seven causes of unemployment in Kenya today. (7 mks)  
(b) Identify seven reasons why leisure is important to Christians. (7 mks)  
(c) In what ways has science and technology improved human life. (6 mks).

# FORM 4 ENDTERM 2 EXAMS

## GEOGRAPHY

### PAPER 1

TIME: 2 ½ HOURS

NAME..... ADM NO:.....

SIGN..... DATE;.....

### INSTRUCTION TO CANDIDATES.

- (a) *This paper consist of two sections A and B.*
- (b) *Answer all questions in section A.*
- (c) *Answer question 6 and any other two in section B.*

#### SECTION A:

*Answer All Questions In This Section.*

1. (a) State three reasons why it is important to study Geography. (3 mks)  
(b) State two forces that contributes to the shape of the Earth. (2 mks)
2. (i) What is an air mass? (2 mks)  
(ii) The actual amount of moisture in a volume of air is 15gm/cc at 20<sup>0</sup>C. The same air could hold a maximum of 20gm/cc at the same temperature. Calculate the relative humidity.
3. (a) State two characteristics of an ideal Stevenson screen. (2 mks)  
(b) Identify two weather recording instruments that are kept in a Stevenson screen. (2 mks)
4. (a) The diagram below shows a cross-section of a Caven in a limestone area.

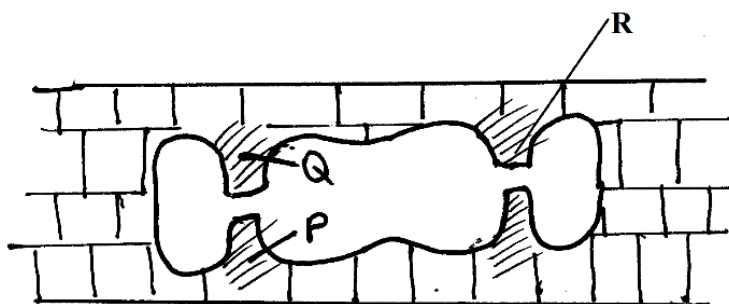

- Name the features marked P, Q and R. (3 mks)
- (b) Briefly, describe carbonation as a weathering process. (3 mks)
5. (i) State three causes of earthquake. (3 mks)
- (ii) State two conditions necessary for the formation of a beach. (2 mks)

**SECTION B: ANSWER QUESTION 6 AND ANY TWO QUESTIONS FROM THIS SECTION.**

6. Study the map of Oyugis 1:50,000 provided and answer the following questions.
- (a)(i) Give the longitudinal extent of the area covered by the map. (1 mk)
- (ii) Convert the scale of the map into a statement scale. (2 mks)
- (iii) What is the approximate height of the hill on Gridsquare 8418. (1 mk)
- (iv) Measure the length of the loose surface road from River Nyangu bridge to the Mizori-Homa Bay Junction in kilometers. (2 mks)
- (b)(i) Calculate the magnetic bearing of Tunga Dam at Grid Reference 705360 from St.Vincent school at GR 750330 as at January 1981. (2 mks)
- (ii) Citing evidence from the map, suggest two economic activities taking place in the area covered in the map. (2 mks)
- (iii) Identify two sources of water in the area covered in the map. (2 mks)
- (iv) Identify two natural vegetation found in the area covered in the map. (2 mks)
- (c) Using a vertical scale of 1cm to rep 50m
- (i) Draw a cross-section from Grid Reference 690400 to Grid Reference 750440. (4 mks)
- (ii) On the cross, mark and name the following
- River Kochido (½ mk)
- Road (½ mk)
- Hill (½ mk)
- 5 ½ mks.
- (iii) Calculate the vertical exaggeration of the area covered by the map. (2 mks)
7. (a)(i) Discuss three factors that cause movement of ocean water. (6 mks)
- (ii) Describe factors influencing transportation of materials along the Coast. (4 mks)
- (b)(i) State three types of submerged highland coasts. (3 mks)
- (ii) With an aid of well labeled diagram describe the formation of a wave-cut platform.(6 mks)
- (c)(i) State six benefits of Coastal landforms. (6 mks)
8. (a)(i) Differentiate between mass wasting and weathering. (2 mks)
- (ii) State four factors that influence the nature and speed of mass wasting. (4 mks)
- (b) Describe four effects of social creep. (8 mks)
- (c) Using a well labeled diagram describe the following mass wasting
- i) Rockfall (4 mks)
- ii) Solifluction (4 mks)
- (d) State three other types of landslide apart from rockfall. (3 mks)



9. (a)(i) What is an ice-sheet. (2 mks)  
(ii) Give two reasons why there are no ice-sheets in Kenya (2 mks)  
(iii) Explain three factors that influence the movement of ice from the place of accumulation. (6 mks)
- (b) Describe how an arete is formed. (4 mks)  
(c) Use the diagram below to answer question C

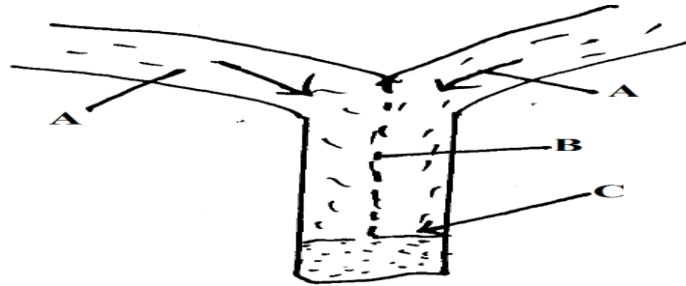

Name the parts marked

A

B

C

(3 mks)

Explain four positive effects of glaciation in the lowland. (8 mks)

10. The table below represents rainfall and temperature of station X and Y.

**STATION X**

MONTHS	J	F	M	A	M	J	J	A	S	O	N	D
TEMPERATURES °C	30	31	31	31	30	29	28	28	29	29	29	30
RAINFALL IN MM	250	250	325	300	213	25	25	25	25	275	280	200

**STATION Y**

MONTHS	J	F	M	A	M	J	J	A	S	O	N	D
TEMPERATURES IN (°C)	21	20	20	17	15	13	12	13	15	16	18	20
RAINFALL IN MM	12	12	15	50	90	110	87	87	50	35	20	15

- (a)(i) Calculate the mean annual range of temperature for the two stations. (2 mks)  
(ii) Calculate the annual rainfall for station Y (2 mks)  
(iii) Using a vertical scale of 1cm to represent 50mm draw a bar graph to represent rainfall for station X. (5 mks)
- (b)(i) Describe climatic characteristics of station Y. (6 mks)  
(ii) Describe how convectional rainfall is formed. (6 mks)  
(iii) Explain the problems associated with convectional rainfall in the lake region of Kenya. (4 mks)

# FORM 4 ENDTERM 2 EXAMS

## GEOGRAPHY

### PAPER 2

TIME: 2 1/2 HOURS

NAME..... ADM NO:.....

SIGN..... DATE;.....

#### INSTRUCTIONS TO CANDIDATES

- This paper has two sections: A and B.
- Answer All the questions in section A.
- In section B answer questions 6 and any other two questions.
- This paper consists of 4 printed pages; Candidates should check this paper carefully to ascertain that all questions are printed and that no question is missing.

#### SECTION A: ANSWER ALL THE QUESTIONS IN THIS SECTION.

- Define the term horticulture. (2 mks)
  - State three characteristics of horticulture farming. (3 mks)
- What is beef farming? (2 mks)
  - Outline three similarities between beef farming in Kenya and Argentina (3 mks)
- Differentiate between fishing and fishery. (3 mks)
  - State three reasons why Norway is a great fishing nation. (3 mks)
- Name two main projects used to reclaim land in Netherlands. (2 mks)
  - Highlight three problems facing irrigation farming in Kenya. (3 mks)
- Briefly highlight two human activities that has influenced wildlife distribution in East Africa. (2 mks)
  - Name three tourism attractions in Switzerland. (3 mks)

#### SECTION B:

#### ANSWER QUESTION 6 AND ANY OTHER TWO QUESTIONS FROM THIS SECTION.

- The table below shows the estimated amount of goods transported through the Nairobi-Mombasa highway in 2002.

Goods transported	Weigh in tones
Lubricating oil	3,000
Fertiliser	5,500
Industrial chemicals	3,500
Total	2,000
	14,000

- Name the town in Kenya where the goods were transported from. (1 mk)
- Use the information in the table to draw a simple divided rectangle 15cm long. (9 mk)

**FOR MARKING SCHEMES CALL/WHATSAPP 0746 222 000**

- (c)(i) Analyse the divided rectangle you have drawn . (3 mks)  
(ii) State two disadvantages of using a simple divided rectangle. (2 mks)
- (d)(i) Give three reasons why road transport is commonly used in Kenya. (3 mks)  
(ii) State three disadvantages of using a pipeline as a means of transporting oil. (3 mks)  
(iii) State four ways in which Kenya benefits from airlinks with other countries. (4 mks)
7. (a)(i) Name three provinces in Canada where wheat is grown in large scale. (3 mks)  
(ii) State four physical conditions that favour wheat growing in Kenya. (4 mks)
- (b) Compare wheat farming in Canada and Kenya under the following sub-headings.  
(i) Storage (2 mks)  
(ii) Transport (2 mks)  
(iv) Market (2mks)
- (c) Explain four types in which the K,T,D,A promotes tea cultivation. (8 mks)
- (d) Your class visited a sugar factory for a field study on sugar processing. State four stages of sugar processing that the class may have observed. (4 mks)
8. (a) Differentiate between Ecotourism and Domestic tourism. (4 mks)  
(b) Explain three factors that have led to the development of tourism in Switzerland. (6 mks)  
(c) Explain the differences between the tourists attraction in East Africa and in Switzerland under the following sub-headings;-  
(i) Climate (2 mks)  
(ii) Culture (2 mks)
- (d) State five reasons why it is necessary to conserve wildlife in Kenya. (5 mks)
- (e) How has the recent negative travel advisories affected Kenya's economy. (6 mks)
9. (a)(i) What is the difference between environmental conservation and environmental management? (2 mks)  
(ii) State four reasons why it is necessary to manage and conserve our environment. (4 mks)
- (b)(i) Identify three regions that are prone to flooding in Kenya. (3 mks)  
(ii) State four problems that results from flooding (4 mks)  
(iii) Explain three measures that are being undertaken to control flooding in the regions identified in b(i) above. (6 mks)
- (c) Students in form four class from your school carried out a field study on pollution in Thika town.  
(i) State two methods you would use to present your data. (2 mks)  
(ii) List three types of pollution they are likely to have identified. (3 mks)
- (d) State any four measures that can be taken to manage and conserve the environment in Kenya. (4 mks)
10. (a) Apart from oil, name two other non-renewable sources of energy . (2 mks)  
(b) Explain four effects that the increase in oil prices has had on the economies of the oil importing countries of Africa. (8 mks)  
(c)(i) What is energy crisis? (2 mks)  
(ii) Explain three causes of energy crisis in African countries. (6 mks)
- (d) What consequences will resort due to oil discovery in Kenya. (3 mks)
- (e) Outline four advantages of Kenya importing her oil in crude form. (4 mks)

# FORM 4 ENDTERM 2 EXAMS

## HISTORY AND GOVERNMENT

### PAPER 1

TIME:2 HOURS

NAME..... ADM NO:.....

SIGN..... DATE;.....

#### **Instructions to candidates**

- a) This paper consists of three sections: A, B, & C.*
- b) Answer all questions in section A, three questions from section B and two questions from section C.*
- c) Answers to all questions must be written in the answer booklet provided.*
- d) This paper consists of 2 printed pages.*
- e) Candidates should check the question paper to ascertain that all the questions are printed as indicated and that no questions are missing.*
- f) Candidates should answer the questions in English.*

#### **SECTION A 25 mks**

**FOR MARKING SCHEMES CALL/WHATSAPP 0746 222 000**

**Answer all the questions**

1. Identify two ways through which archaeologist obtain information on history and government. (2mks)
2. State the scientific theory that explains the origin of human beings. (1mk)
3. Name two agricultural machines that were invented by Jethro Tull. (2mks)
4. Identify one type of trade. (1mk)
5. Give two limitations of using animal transport. (2mks)
6. Identify one way in which telecommunication has facilitated modern trade. (1mk)
7. Name two metals that were used as currency in pre-colonial Africa. (2mks)
8. List the items which were kept to preserve the history of the Royal family in the Baganda kingdom during pre-colonial period. (2mks)
9. Name the chartered company that administered Zimbabwe during the process of colonization. (2mks)
10. Identify one German colony in West Africa. (1mk)
11. Name one treaty signed between Lubengula and British during the process of colonization of Africa. (1mk)
12. Name the organ of the United nations that promotes justice in the world. (1mk)
13. Name the members of the Economic Community of West African States(ECOWAS). (2mks)
14. Give the main incident which made Japan to surrender unconditionally to the Allied powers in 1945. (1mk)
15. Give two categories of persons who are disqualified for a constituency seat in Britain. (2mks)
16. Give two disadvantages of using drumbeats to pass message. (2mks)
17. Name the super power from Europe involved in the cold war. (1mk)

**SECTION B (45 marks)**

**Answer three questions only**

18. (a) State five reasons why early people domesticated crops and animals during the Neolithic period. (5mks)
- (b) Explain five factors that led to Agrarian revolution in United States of America (USA). (10mks)
19. (a) Identify five functions of London as an urban centre. (5mks)
- (b) Explain factors that led to emergence of Japan as an industrial power. (10mks)
20. (a) Identify five reforms made by Germans after maji maji rebellion in Tanganyika. (5mks)
- (b) Explain the terms of Corydon treaty (1900) (10mks)
21. (a) Give five external factors that led to the rise of nationalism in Africa. (5mks)
- (b) Discuss the problems that were encountered by African Nationalist in South Africa during their struggle for majority rule. (10mks)

**SECTION C (30MKS)**

**Answer two questions only**

22. (a) Give three reasons why United States of America joined the first world war. (3mks)
- (b) Explain the reasons why the league of nations failed to maintain world peace and security. (12mks)
23. (a) State three reasons why the fifth Pan-African conference of 1945 was unique. (3mks)
- (b) Explain the factors undermining the activities of the African Union (AU) since its formation in 2001. (12mks)
24. (a) What are the duties of Prime minister in India. (3mks)
- (b) Explain the roles of congress in United State of America. (12mks)

# FORM 4 ENDTERM 2 EXAMS

## HISTORY AND GOVERNMENT

### PAPER 2

TIME:2 HOURS

NAME..... ADM NO:.....

SIGN..... DATE;.....

#### **Instructions to candidates**

- a) This paper consists of three sections: A, B, & C.
- b) Answer all questions in section A, three questions from section B and two questions from section C.
- c) Answers to all questions must be written in the answer booklet provided.
- d) This paper consists of 2 printed pages.
- e) Candidates should check the question paper to ascertain that all the questions are printed as indicated and that no questions are missing.
- f) Candidates should answer the questions in English.

**SECTION A (25MKS)**

**FOR MARKING SCHEMES CALL/WHATSAPP 0746 222 000**

**Attempt all the questions from this section**

1. Name two treaties that were signed that marked colonial spheres of influence in East Africa. (2mks)
2. Name one agricultural scheme introduced in Kenya after independence. (1mk)
3. Identify two social causes of disunity in Kenya today. (2mks)
4. State two functions of council of elders in Kenyan societies up to the 19th century. (2mks)
5. Give two natural factors that facilitated contact between the Kenyan coast and the outside world by 1500AD. (2mks)
6. State the main function of the legislature in Kenya . (1mk)
7. Identify one fundamental principle of the concept of natural justice. (1mk)
8. State two forms of ownership advocated by African socialism in Kenya. (2mks)
9. Under which two circumstances can a court of law restrict one's freedom of movement? (2mks)
10. Identify one factor which motivated the rise of nationalism in Kenya. (1mk)
11. Define the term democracy. (1mk)
12. State the importance of cultural activities in Kenya. (1mk)
13. State two negative effects of urbanization in Kenya. (2mks)
14. Name the administration system used by the British in their rule over Kenya. (1mk)
15. State one challenge that faces the police force in Kenya today. (1mk)
16. Identify ant two education commissions established in Kenya since independence. (2mks)
17. Give one reason why oathing was necessary among Mau Mau fighters. (1mk)

**SECTION B (45MARKS)**

**Answer Any Three Questions From This Section**

18. (a) Identify five ways how Kenyan communities interacted during the pre-colonial period . (5mks)
- (b) Describe the social organization of the Luo during the pre-colonial period. (10mks)
19. (a) Identify five roles played by women in the struggle for Kenya's independence. (5mks)
- (b) Explain five reasons that made the imperial British East African Company (IBEACO) to surrender its charter to Britain in 1894. (10mks)
20. (a) State five political challenged encountered by Kenyatta's government up to 1968. (5mks)
- (b) Explain five factors that led to the demands for multiparty democracy during the Moi era. (10mks)
21. (a) State five factors which limit the activities of co-operative societies in Kenya. (5mks)
- (b) Explain five functions of cooperative societies in Kenya. (10mks)

**SECTION C (30MKS)**

**Answer any two questions from this section**

22. (a) Outline three ways through which Kenyan parliament exercises control over the executive arm of the government. (3mks)
- (b) Explain six factors that may undermine the administration of justice in Kenya. (12mks)
23. (a) Give three reasons why the Kenyan government prepares an annual national budget. (3mks)
- (b) Discuss six ways in which the government of Kenyan ensures its revenue is not misused. (12mks)
24. (a) Identify five functions of the Independence Electoral and Boundaries Commission of Kenya. (5mks)
- (b) Explain the challenges faced by the Electoral Commission of Kenya. (10mks)

# FORM 4 ENDTERM 2 EXAMS

## ENGLISH

PAPER 1

### FUNCTIONAL SKILLS

TIME:2 HOURS

NAME..... ADM NO:.....

SIGN..... DATE;.....

#### INSTRUCTIONS TO CANDIDATES

- a) Answer all the questions in this question paper.
- b) All your answers must be written in the spaces provided in this question paper.

#### FOR EXAMINER'S USE ONLY

Question	Maximum score	Candidate's Score
1	20	
2	10	
3	30	
<b>Total score</b>	<b>60</b>	

(FUNCTIONAL SKILLS)

**FOR MARKING SCHEMES CALL/WHATSAPP 0746 222 000**







## 2. CLOZE TEST (10 Marks)

**Fill in the blank spaces in the following passage using the most appropriate word.**

In normal situations, children's aggressive behaviors wear \_\_\_\_\_ 1 \_\_\_\_\_ as the ability to express their desires and \_\_\_\_\_ 2 \_\_\_\_\_ develops. Children whose aggression \_\_\_\_\_ 3 \_\_\_\_\_ not decline with time lose their temper frequently and are \_\_\_\_\_ 4 \_\_\_\_\_ extremely irritated and frustrated over minor issues. They are also disruptive and antagonize \_\_\_\_\_ 5 \_\_\_\_\_ by hitting, pushing, yelling and name \_\_\_\_\_ 6 \_\_\_\_\_ threatening and teasing. They habitually \_\_\_\_\_ 7 \_\_\_\_\_ physical or psychological \_\_\_\_\_ 8 \_\_\_\_\_ on others. As a result, they have trouble with their peers and often face rejection.

Studies have established that boys are three times more \_\_\_\_\_ 9 \_\_\_\_\_ than girls to be aggressive owing to the concentration in of the male hormones, androgen and testosterone. And children who are \_\_\_\_\_ 10 \_\_\_\_\_ to aggression are more likely to act aggressively than those who.....

## 3. ORAL SKILLS [30 MARKS]

(a) **Read the following poem and answer the questions that follow. (10mks)**

### THE SEED SHOP

Here in a quiet and dusty room they lie,  
Folded as crumbled stone or shifting sand,  
Forlorn ashes, shriveled scentless dry,  
Meadows and gardens running through my hand.

In this brown husk a sale of hair throne dreams,  
A cedar in this narrow cell is thrust,  
That will drink deeply of a century's streams,  
These lines shall make summer on my dust,  
Here is their safe and simple house in death.  
Sealed in their shells a million roses leap.  
Here I can blow a garden with my breath,  
And in my hand a forest lies asleep.

**Identify the following from the poem.**

(i) Two pairs of rhyming words. (2marks)

.....  
.....

(ii) Two examples of alliteration. (2marks)

.....  
.....

(iii) Two examples of assonance. (2marks)

.....  
.....

(iv) One example of repetition. (2marks)

.....  
.....

(v) Describe the rhyme schemes of the poem. (2marks)

.....  
.....

(b) **Explain the difference in meaning in the following sentences if you put stress in the underlined words.** (5marks)

(i) They destroyed the house which the thieves lived in.

.....  
.....

(ii) They destroyed the house which the thieves lived in.

.....  
.....

(iii) They destroyed the house which the thieves lived in.

.....  
.....

(iv) They destroyed the house which the thieves lived in.

.....  
.....

(c) **Identify the odd one out in terms of pronunciation .** (5marks)

- (i) pleasure                      sugar                      leisure.
- (ii) champion                      Chevrolet                      champagne.
- (iii) conscious                      conscience                      science
- (iv) azure                      zeal                      Xerox
- (v) respond                      resist                      recommend

(d) It is late afternoon. There is a talk going on in the main hall, but you observe that quite a number of the members of the audience are restless and dozing.

What could be the problem? (4marks)

.....

.....

.....

.....

.....

.....

.....

.....

.....

(e) **State the meaning of the following body movements.** (2marks)

(i) Fidgeting in your seat.

.....

.....

(ii) Pacing up and down.

.....

.....

(f) **For each of the following letters, provide a word in which the letter s is silent.** (4marks)

- (i) r \_\_\_\_\_.
- (ii) w \_\_\_\_\_.
- (iii) b \_\_\_\_\_.
- (iv) s \_\_\_\_\_.

# FORM 4 ENDTERM 2 EXAMS

## ENGLISH

### PAPER 2

(Comprehension, Literary appreciation and Grammar)

TIME:2 ½ HOURS

NAME..... ADM NO:.....

SIGN..... DATE;.....

#### INSTRUCTIONS TO CANDIDATES

*c) Answer all the questions in this question paper.*

*d) All your answers must be written in the spaces provided in this question paper.*

#### FOR EXAMINER'S USE ONLY

Question	Maximum score	Candidate's Score
1	20	
2	25	
3	20	
4	15	
<b>Total score</b>	<b>80</b>	

**1 Read the passage below and then answer the questions that follow.**

We are moving inexorably into the age of automation. Our aim is not to devise a mechanism which can perform a thousand different actions of any individual man, but, on the contrary, one which could, by a single action, replace a thousand men.

Industrial automation has moved along three lines. First, there is conveyor belt system of continuous production whereby separate operations are linked into single sequences. The goods produced by this well-established method are untouched by the worker, and the machine replaces both skilled and semi-skilled.

Secondly, there is automation with feedback control of the product. Here mechanisms are built into the system which can compare the output with a norm, that is, the actual product with what it supposed to be, and then correct any shortcomings. The entire cycle of operations dispenses with human control except in so far as monitors are concerned. One or two examples of this type of automation will illustrate its immense possibilities. There is a factory in the USA which makes 1,000 million electric lights bulbs a year, and the factory employs three hundred people. If the pre-automation were to be employed, the labour force required would leap to 25000. A motor manufacturing company with 45000 spare parts assembles their entire supply entirely by computer. Computers can be entrusted with most of the supervision of industrial installations, such as chemical plants or oil refineries.

Thirdly, there is computer automation, for banks, accounting departments, insurance companies and the like. Here the essential features are recording, storing and retrieval of information.

The principal merit of modern computing machines is the achievement of their vastly greater speed of operation in comparison with unaided human effort; a task which otherwise might take years, if attempted at all, now takes days or hours.

One of the urgent problems of industrial societies rapidly introducing automation is how to fill the time that will be made free by the machines which will take over the risks of the workers. The question is not simply of filling empty time but also of utilising the surplus human energy that will be released. We are already seeing straws in wind: destructive outbursts on the part of the youth whose work no longer demands muscular strength. While automation will undoubtedly do away with a large number of tedious jobs, are we sure that it

will not put others which are equally tedious in their place? An enormous amount of monitoring will be required. A man in an automated plant may have to sit for hours on end watching dials and taking decisive action when some signals inform him that all is not well. What meaning will his occupation bear for the worker? How will he devote his free time after a four or five hour stint of labour? Moreover, what, indeed, will be the significance of his leisure to him? If the industry of the future could be purged of its monotony and meaninglessness, man would then be better equipped to use his leisure time constructively.

*[Adapted from practice tests for Proficiency by Margret Archer and Enid Nolan-Woods, Thomas Nelson and Sons]*

**Questions**

1. What are the benefits of automation?

(2 marks)

2. Explain the main achievement of modern computing.

(1 mark)

3. Outline the problems created by industrialization

(4 marks)

4. Explain the line

(1 mark)

‘We are already seeing the straws in the wind.....’

5. Summarize the author’s argument in favour of automation and the problems created by the same, in not more than 90 words. (6 marks)

6. *Explain the meaning of the following words as used in the passage.* (4 marks)

- i) Immense
- ii) Retrieval
- iii) Tedious
- iv) Inexorably

7. *Rewrite the following sentence according to the instructions given.* (1 mark)

‘If the industry of the future could be purged of its monotony and meaninglessness, man would then be better equipped to use leisure time constructively.’

(Use: If.....purged .....’)

8. *Rewrite the sentence below using a phrasal verb instead of the underlined word.*

(1 mark)

‘The entire cycle of operations dispenses with human control expect in so far as monitors are concerned.’

## **2. Read the excerpt below and answer the questions that follow.**

**Helmer:** (calls out from his room) is that my little lark twittering out there?

**Nora:** (busy opening some of the parcels) Yes, it is!

**Helmer:** Is it my little squirrel bustling about?

**Nora:** Yes!

**Helmer:** When did my squirrel come home?

**Nora:** Just now (puts the bag of macaroons in to her pocket and wipes her mouth.) Come in here, Torvald, and see what I have bought.

**Helmer:** Don’t disturb me. (A little later, he opens the door and looks into the room, pen in hand.) Bought, did you say? All these things? Money again? Has my little spendthrift been wasting?

**Nora:** Yes but, Torvald, this year we really can let ourselves go a little. This is the First Christmas that we have not needed to economize

**Helmer:** Still you know, we can’t spend money recklessly.

**FOR MARKING SCHEMES CALL/WHATSAPP 0746 222 000**



**Nora:** Yes, Torvald, we may be a wee bit more reckless now, mayn't we? Just a tiny wee bit! You are going to have a big salary and earn lots and lots of money.

**Helmer:** Yes after the New Year; but then it will be a whole quarter before the salary is due.

**Nora:** Pooh! We can borrow until then.

**Helmer:** Nora! (**Goes up to her and takes her playful by the ear**)The same little featherhead! Suppose now, that it borrowed fifty pounds today, and you spent it all in the Christmas week and then on New Year's Eve a slate fell on my head and killed me, and-

**Nora: (putting her hands over his mouth)** Oh don't say such horrid things.

**Helmer:** Still, suppose that happened,--what then?

**Nora:** If that were to happen, I don't suppose I should care whether I owed money or not.

**Helmer:** Yes, but what about the people who has lent it?

**Nora:** They? Who would bother about them? I should know who they were.

1. Explain what happens just before this excerpt (3 marks)
2. From the above, what kind of a woman is Nora? (4marks)
3. Briefly identify and illustrate Helmer's character traits as brought out in the passage (4 marks).
4. From your knowledge of the book, why do you think Nora said, "We may be a wee bit reckless now, mayn't we?" (2 marks)
5. Identify and illustrate one style used in the excerpt (2 marks)
6. From the Excerpt, comment on Nora and Helmer's relationship. (2 marks)
7. Discuss two thematic issues in the extract. (4 marks)
8. I don't suppose I should care whether I owed money or not.(supply a question tag) (1 mark)

***Explain the meaning of the following words as used in the passage.***

- i) Horrid
- ii) Featherhead
- iii) Spendthrift

**Read the following oral poem and answer the questions that follow (20 marks)**

Oh! It has dawned  
You ask for a loincloth to take where?

iiii It has dawned  
You ask for a loincloth to take where?

Uncircumcised man of Ngiro  
It has dawned  
What do you need a loincloth for?

Now only your mother can help you  
Uncircumcised man of Ngiro

**FOR MARKING SCHEMES CALL/WHATSAPP 0746 222 000**

What do you need a loincloth for?

Won't you call your mother to plead with you?

Oh! It has dawned

What do you need a loin cloth for?

1. Classify the above oral poem (2 marks)
  
2. Identify four performance features that stands out in the above oral poem ( 8 marks)
  
  
  
  
  
  
  
3. Discuss dominant tone of the above oral poem ( 3 marks)
  
  
  
  
  
  
4. Oh! It has dawned (add a question tag) (1 mark)
  
  
5. What are the roles of the above song? (2 marks)
  
  
  
  
6. Who is the singer? (2marks)
  
  
  
  
7. Explain one vice that is discouraged in the oral poem (2 marks)

## **GRAMMAR**

1. For each of the following sentences replace the underlined words with a phrasal verb which begins With the word in brackets to convey the same meaning

**FOR MARKING SCHEMES CALL/WHATSAPP 0746 222 000**

- i) The suspicious behavior betrayed him (give)
- ii) Please ensure that everyone gets something to eat and drink (see)
- iii) It was clear that we had invented the whole story (make)

2. **Fill in the blanks with correct conjunctions**

- i) .....somewhat pompous, he was an entertaining.  
Companion.
- ii) Many things have happened .....I left school.
- iii) I have never seen him .....that unfortunate event took  
place.

3. **Complete the following sentences using the appropriate form of the word in brackets**

- i) I told her that I was .....for her help (gratitude)
- ii) The elections results were upheld because of the officers.....(partial)
- iii) After the fight, Monda went off to wash her.....(blood)

4. **Rewrite the following sentences according to the instruction given** (3marks)

- i) Goods once sold will not be returned under any circumstances  
(Begin: under
- ii) Muhiga works in a factory .....(add a  
question tag)
- iii) Rukia bought the house at the corner for seven million shillings yesterdays (change to  
passive)

5. **Fill in the blanks with appropriate pronoun** (3marks)

- i) Mukunga writes faster than..... (I, me)
- ii) .....students were the first to arrive. (us, we)
- iii) Between you and ....., one of us is lying. (me, I)

# FORM 4 ENDTERM 2 EXAMS

## ENGLISH

(CREATIVE COMPOSITION and ESSAYS BASED on SET TEXTS)  
PAPER 3

TIME:2 ½ HOURS

NAME..... ADM NO:.....

SIGN..... DATE;.....

### INSTRUCTIONS TO CANDIDATES:

1. *Answer three questions only*
2. *Question one and two is compulsory.*
3. *In question three choose only one optional text you have prepared on.*
4. *Where a candidate presents work on more than one optional text, only the first one to appear will be marked.*
5. *Each of your essays should not exceed 450 words.*

## **Answer three question only**

### **1. Imaginative composition**

(a) Write a composition to illustrate the saying: “A poor workman quarrels with his tools.”

**Or**

(b) Write a composition beginning, “When I saw the two policemen, I knew there was trouble.....”

### **2. The Compulsory Set Text**

In the novel, Blossoms of the Savannah, Ole Kulet goes out of his way to castigate some Maa way of life. Write an essay to show the validity of this statement with close reference to the novel. (20 marks)

### **3. The Optional Texts**

**Either**

#### **(a) The short stories**

Describe the devastating effects that conflicts have on the innocent children and women in Mariatu Kamara’s “The President” in “Memories we Lost and other stories”.

**Or**

#### **(b) Drama**

A mother can bear a child and he or she (the child) is a replica of her, but can also be very different. Write an essay comparing and contrasting the character of Luli Zen Melo with that of her mother Tamina Zen Melo” with clear illustrations from “Inheritance” by David Mulwa.

**Or**

#### **(c) The Novel**

“A society driven by greed suffers a lot” Using illustrations from “The Pearl” by John Steinbeck, write an essay to support the above statement.

# FORM 4 ENDTERM 2 EXAMS

## KISWAHILI

KARATASI YA KWANZA

INSHA

TIME:1 ¾ HOURS

NAME..... ADM NO:.....

SIGN..... DATE;.....

### MAAGIZO:

- a) Andika insha mbili. insha ya kwanza ni ya lazima.
- b) Insha ya kwanza ni ya lazima
- c) Kisha chagua insha nyingine moja kati ya hizo tatu zilizobakia.
- d) Kila insha isipungue maneno 400.
- e) Kila insha ina alama 20.

1. Andika wasifu wa ndugu yako ambaye amepanga hafla ya kuchangisha pesa za kugharamia masomo ya chuo kikuu. (al.20)

2. Ufisadi ndicho kikwazo kikuu katika maendeleo ya kiuchumi katika taifa lolote. Thibitisha. (al.20)

3. Andika insha inayobainisha maana ya methali , “Bahati ya mwenzio usilalie mlango wazi”. (al.20)

4. Tunga kisa kinachoanza kwa maneno yafuatayo.

Mara tu nilipokivuka kizingiti cha lango la nyumba yangu, nilijua kwamba maisha yangu yalikuwa yamechukua mkondo mpya. (al.20)

# FORM 4 ENDTERM 2 EXAMS

## KISWAHILI

KARATASI YA PILI

LUGHA

TIME:2 ½ HOURS

NAME..... ADM NO:.....

SIGN..... DATE;.....

### MAAGIZO:

- Andika **namba yako** na **jina lako** katika nafasi ulizoachiwa hapo juu
- Weka **sahihi** yako **natarehe** ya mtihani katika nafasi zilizoachwa hapo juu.
- Jibu maswali yote.
- Andika **Majibu** yako katika nafasi zilizoachwa katika kijitabu hiki cha maswali
- Karatasi hii ina kurasa **9** zilizopigwa chapa.Watahiniwa ni lazima waangalie kama kurasa zote za karatasi hii zimepigwa chapa
- Watahiniwa ni lazima wahakikishe kwamba kurasa **zote** za karatasi hii zimepigwa chapa sawasawa na kuwa maswali yote yamo.

### KWA MATUMIZI YA MTAHINI PEKEE:-

SWALI	UPEO	ALAMA
1 – Ufahumu	15	
2 – muhtasari	15	
3 – matumizi ya lugha	40	
4 – ismu jamii	10	
<b>JUMLA</b>	<b>80</b>	

# UFAHAMU (ALAMA 15)

## Soma makala yafuatayo kisha ujibu maswali.

Teknolojia mpya ni tawi la maarifa linalohusiana na sayansi kwa upande mmoja na uhandisis (uinjinia) kwa upande mwingine. Sayansi ni elimu inayotokana na uchunguzi na majaribio katika maabara. Nao uhandisi ni ujuzi wa kuunda mitambo. Maarifa ya sayansi yanapotumiwa kutengeneza vitu viwandani hali hii inakuwa teknolojia.

Zao mojawapo la teknolojia mpya ni simu tamba. Watu vijijini sasa wanawasiliana na jamaa zao walio mbali. Akina nyanya wanapopanda njugu, kupalilia migomba, kukama ngamia au kukuna nazi, wanaweza kuzungumza na wajukuu wao walio Uingereza, Uchina au kwingine kule.

Hakuna mahali ambapo hapajafikwa na teknolojia mpya. Tukitembelea baadhi ya nyumba tutaona vifaa kama vila tanuri la miale au maikrowevu ambalo linapika maharagwe yakaiva kwa dakika chache tu. Majokofu nayo yanatuwezesha kuhifadhi vyakula bila kuharibika. Hata maiti na mizoga inaweza kuhifadhiwa kwa miaka mingi kwa ajaili ya utafiti bila kuoza katika ufuo au mochari.

Kwa upande wa kilimo, teknolojia imefanya makubwa. La kustaajabisha ni mtu mmoja kulima eneo kubwa la shamba kwa trekta. Halafu akapanda kwa tandazi, kunyunyizia dawa, kunyausha magugu, akavuna na na kukoboa mahindi akiwa peke yake. Siku hizi inawezekana kukuza mimea na kufuga wanyama wanaokomaa kwa muda mfupi na kutoa mazao maradufu kwa sababu ya teknolojia mpya.

Teknolojia imewezasha watu kuvumbua aina nyingi za nishati. Badala ya kutegemea umeme unaotokana na maji tu, sasa watu wanatumia mvuke, nguvu za upepo na nishati ya jua kupataumeme. Kwa sababu hii hata mababu zetu vijijini wanatazam televisheni bila shida wala wahka.

Kwa upande mwingine, teknolojia ina madhara yake. Kwa mfano, uundaji wa silaha kali unaendelea kuwaangamiza watu wengi. Mabomu ya kitororadi yaliyoangushwa Hiroshima na Nagasaki Japan mwaka 1945 ni zao la kisayansi. Haya yaliwaua watu wengi na madhara yake bado yanadhahirika hata leo katika maumbile ya watoto wanaozaliwa na upungufu. Tena magaidi na wahalifu wa kimataifa wanatumia teknolojia mpya kuimarisha mbinu zao za kutendamaovu. Isitoshe, inawezakana kutumia teknolojia kuagiza benki kutuma pesa nje ya nchi bila mwenye hazina kujua.

Wahalifu wanaweza kusikiza mawasiliano ya watu kwa simu hata ikiwa ni baina ya polisi. Vilivile matatizo mengi ya kiafya yasemekana yanatookana na vyakula vilivyokuzwa kwa kutumia teknolojia mpya.

Katika usafiri, Kuna garimoshi lenye kutumia stima badala ya makaa. Hili ni zao la teknolojia mpya vilevile. Ingawa mwendo wake ni wa kasi, kasi hiyo na stima huweza kusababisha ajali mbaya mno.

Ingawa madhara yapo lakini manufaa ya teknolojia ni mengi zaidi kuliko madhara yenyewe. Faida ni kuwa teknolojia hurahisisha shughuli za watu kama vile kufua na kusafiri. Pia hufanya matokeo ya shughuli kuwa bora zaidi. Kazi iliyopigwa chapa kwa kompyuta huwa safi na bora. Vile vile vitu vinavyotengenezwa siku hizi ni vidogo na vyepesi lakini ni bora zaidi. Tukichukua mfano wa magari tunaona kuwa ni madogo lakini yenye muundo wa kuvutia. Tatizo tu ni ile kasi kubwa ambayo ni moja ya mambo yanayosababisha ajali nyingi.

Gharama ya vitu vinavyotengenezwa kutumia teknolojia mpya ni nafuu. Teknolojia hii inatumia malighafi ya kisasa na hivyo kuhifadhi madini yetu. Pia huunda vitu ambavyo matumizi yake hayadhuru mazingira.

Tusisahau kuwa hata hapa kwetu matekinia wa jua kali wanapiga hatua. Wanajitahidi usiku na mchana kuunda vitu vya kutuuzia kwa gharama nafuu. Mitambo ya kusukuma maji sasa inapatikana. Vyombo vya kusafirisha mizigo, vifaa vya kunyunyuzia maji, tanuri ya kuoka inayohifadhi nishati na vingine vingi, sasa vinaundwa ili kuimarisha sekta hii. Ikiimarika, Kenya inaweza kuwa nchi yenye uwezo wa viwanda.

**MASWALI**

**FOR MARKING SCHEMES CALL/WHATSAPP 0746 222 000**



a) Toa anwani mwafaka ya taarifa hii. **(alama**

1)

.....  
.....  
.....

b) Eleza umuhimu wa teknolojia mpya kwa zaraa. **(alama**

2)

.....  
.....  
.....

c) “Kwa hakika uhandisi umepiga hatua.” Thibitisha kauli hii kulingana na taarifa. **(alama**

2)

.....  
.....  
.....

d) “ Hakuna mahali ambapo hapajafikiwa na teknolojia.” Unga mkono kauli hii. **(alama**

2)

.....  
.....  
.....  
.....

e) Uvumbuzi wa kiteknolojia umesaidiaje ulimwengu kupunguza gharama ya uzalishaji wa bidhaa? **(alama**

3)

.....  
.....  
.....  
.....

f) Taja athari zozote mbili za kughasi za uvumbuzi. **(Alama**

2)

.....  
.....  
.....  
.....

g) Taja jambo lolote linaloonyesha jinsi uvumbuzi umeibuka na anasa ya kipekee. (Alama 1)

.....  
.....  
.....

h) Eleza maana ya msamiati huu kama ulivyotumia kwenye taarifa . (alama 2)

i) Malighafi

.....  
.....  
.....

ii) Matekinia

.....  
.....  
.....

**UFUPISHO (ALAMA 15)**

**Soma taarifa ifuatayo kisha ujibu maswali kulingana na maagizo**

Imesemwa na kurudiwa kwamba, iwapo tuna maono ya kujiondoa katika umasakini wa kupindukia, ni lazima tukipe kilimo umuhimu. Zaidi ya Wakenya milioni kumi wamo katika hatari ya kufa njaa katika maeneo mbalimbali kwa sasa kufuatia uhaba wa chakula nchini.

Kiini kikubwa cha njaa hiyo ni mapuuzo ya muda mrefu katika sekta ya kilimo. Imesahaulika kuwa karibu asilimia sabini na tano ya wakenya wanategemea kilimo kwa chakula na mapato ya kifedha kila siku. Kilimo hutoa karibu robo tatu ya nafasi za kazi kwa mwananchi na pia kuletea serikali karibu robo ya mapato yake kutokana na mauzo ya mazao katika mataifa ya nje.

Wataalamu wa maswala ya zaraa wanaeleza kuwa pato la nchi linalotokana na kilimo huangamiza njaa mara zaidi ya mapato yanayotokana na shughuli nyinginezo za kiuchumi. Hiyo ni kwa sababu shughuli za kilimo hulenga kuzalisha vyakula moja kwa moja.

Imebainika kuwa mataifa mengi yanayostawi, asilimia sabini na tano ya wananchi huishi katika maeneo ya mashambani na idadi hii hutegemea kilimo kujimudu kimaisha ilhali hapa kenya ni asilimia nne pekee ya bajeti inayowekezwa katika kilimo. Kwa wakati huo, ushuru unaotowza bidhaa za kilimo katika maeneo haya umebainika kuwa mkubwa. Hii imepelekea uwekezaji katika kilimo kupungua na hivyo kuchangia kukithiri kwa baala njaa.

Wakati umewadia kwa serikali za Afrika na wapangaji wa masuala ya uchumi kuweka juhudi maradufu katika kushabikia kilimo ili kumaliza njaa na umaskini. Kuna haja ya kuwajulisha, kuwahimiza na kuwaelimisha wakulima wa mashamba madogo madogo kuhusu mihimili ya zaraa kama vile uzalishaji wa matunda na mboga ufugaji wa ndege, samaki na ng'ombe mbali na kuweka mikakati ya kuanzisha nafasi za kazi katika sekta ya kilimo.

Serikali itafikia lengo hili iwapo itaanza kufadhili kilimo, Kupunguza ghrama za pembejeo za kilimo. Kuweka sera zinazodhibiti uuzaji na ununuzi wa vyakula hasa baina ya mataifa na kuongeza sehemu ya bajeti inayotengewa kilimo. Bila hilo hatutakuwa na lingine bali na kukimbilia mataifa yaliyostawi kuomba misaada ili kuwanusuru raia wetu kutokana na ghadhabu ya njaa.

**MASWALI**

a) Fupisha aya mbili za mwanzo kwa maneno 50-55.

**(Alama 6)**

**Matayarisho**

.....  
.....  
.....  
.....  
.....  
.....  
.....  
.....  
.....  
.....  
.....

**Jibu**

.....  
.....  
.....  
.....  
.....  
.....  
.....  
.....  
.....  
.....  
.....

b) Bila kubadili maana, fupisha aya mbili za mwisho. (maneno 55-60)

**Matayarisho**

.....  
.....  
.....  
.....  
.....  
.....  
.....  
.....  
.....  
.....  
.....

**Jibu**

.....  
.....  
.....

.....  
.....  
.....  
.....  
.....  
.....  
.....  
.....

**MATUMIZI YA LUGHA (ALAMA 40)**

a) Taja sauti zifuatazo (alama 2)

i) Irabu ya chini wastani

.....  
.....

ii) Kipasuo sikhuna cha kaaka laini

.....  
.....

b) Unda maneno yenye miundo ya silabi ifuatayo . (alama 2)

i) **KKVKKV**

.....  
.....

ii) **KVKKKV**

.....  
.....

c) Andika sentensi ifuatayo katika wingi (alama 2)

Ukimwona mwanafunzi mzembe nijulishe mara moja.

.....  
.....  
.....  
.....

d) Iandike sentensi hii upya kwa kutumia ò- ote' (alama 2)

Kila mchezaji anapaswa kufanya bidii.

.....  
.....  
.....

e) Eleza jinsi neno kwake lilivyotumika katika sentensi zifuatazo: (alama 3)

i) Kwake kumefagiliwa vizuri

.....  
.....

ii) Kuimba kwake kulipendeza san

.....  
iii) Mwalimu ameingia kwake.

.....  
f) Andika katika hali ya udogo **(alama 2)**  
Mbuzi aliyechinjwa jana kwa kisu alikuwa mtamu.

.....  
g) Yakinisha sentensi hii kwa njia mbili tofauti **(alama2)**  
Hachezi mpira wa kandanda.

.....  
h) Andika kinyume cha sentensi hii. **(alama 2)**  
Mvulana aliyekwea mlima alisifiwa na wananchi.

.....  
i) Baianisha maneno katika senternsi hii. **(alama 3)**  
Mimi na dadangu tulisimama kando ya barabara

.....  
j) Unda nomino dhahania kutokana na vitenzi vifuatavyo. **(alama 2)**  
i) Ogopa

.....  
ii) –la

.....  
k) Andika sentensi hii ifuatayo kwa usemi halisi. **(alama 3)**  
Mhubiri alitaka kujua iwapo waumini walikuwa wameelewa mahubiri ya siku hiyo.

.....  
l) Andika sentensi hii upya kwa kutumia ‘o’ rejeshi ili kuleta dhana ya hali ya mazoea. **(alama 2)**  
Jembe wanalolimia lina makali.

m) Eleza matumizi ya viambishi vilivyopigiwa mistari

(alama2)

i) Chezeni

.....  
.....

ii) Afanyiapo

.....  
.....

iii) Nitakupiga

.....  
.....

iv) Afanyapo

.....  
.....

n) Changanua sentensi hii kwa kielelezo cha mishale .  
Timu yetu ilicheza vizuri lakini haikushinda.

(alama 4)

.....  
.....  
.....  
.....

o) Andika visawe vya maneno haya.

(Alama 2)

i) Ufizi

.....

ii) Damu

.....

p) Eleza maana za neno : beberu

(alama 2)

.....  
.....  
.....

q) Tambua tamathali za usemi zilizotumika katika sentensi zifuatazo.

(Alama 2)

i) Tuondoke sasa bwana, giza limepiga hodi.

.....  
.....  
.....

ii) Watu wengi walihudhuria sherehe hizo, si watoto, si vijana, si watu wazima.

.....  
.....  
.....

r) Bainisha kirai kilichopigiwa mstari

(alama 1)

Alisimama mbele ya hadhira kutoa hotuba yake.

.....  
.....  
4. **Isimu jamii** (alama 10)

**Soma kifungu hiki kisha ujibu maswali**

Anageuka, kushaoto kulia.....amepiga ile ngoma kwa Aucho.....  
Aucho..... Chenga moja mbili. Hatari ! Hatari ! Lakini bado ! Bahati haisimami ! Lo Lahaula la  
kwata !.....Goalless

a) Hii ni sajili gani (alama 2)

.....  
.....  
.....  
.....

b) Eleza sifa nane za sajili hii (alama 8)

.....  
.....  
.....  
.....  
.....  
.....  
.....  
.....  
.....  
.....  
.....  
.....  
.....  
.....  
.....  
.....  
.....  
.....  
.....  
.....  
.....  
.....

# FORM 4 ENDTERM 2 EXAMS

## KISWAHILI

KARATASI YA TATU

### FASIHI YA KISWAHILI

TIME: 2 ½ HOURS

NAME..... ADM NO:.....

SIGN..... DATE;.....

MAAGIZO:

*1. Jibu maswali MANNE Pekee.*

*2. Swali la kwanza ni la lazima.*

*3. Maswali mengine yachaguliwe kutoka sehemu zilizobaki.*

*4. Usijibu maswali mawili kutoka sehemu moja.*

*5. Kila swali lina alama ishirini*

#### 1. SEHEMU A: USHAIRI (LAZIMA)

Eti

Mimi niondoke hapa

Niondoke hapa kwangu

Nimesaki, licha ya risasi

Vitisho na mauaji, siondoki

Mimi

Siondoki

Siondoki siondoki

Niondoke hapa kwangu!

Kwa mateke hata na mikuki

Marungu na bunduki, siondoki

Hapa

Siondoki

**FOR MARKING SCHEMES CALL/WHATSAPP 0746 222 000**



Mimi ni Pahame!  
Niondoke hapa kwangu!  
Fujo na ghasia zikizuka  
Na kani ya waporaji, siondoki

Haki  
Siondoki  
Kwangu siondoki  
Niondoke hapa kwangu!  
Nawaje; waje wanaokuja  
Mabepari wadhalimu, siondoki

Kamwe  
Siondoki  
Ng'oo hapa kwangu!  
Katizame chini mti ule!  
Walizikwa babu zangu, siondoki

Sendi  
Nende wapi?  
Si hapa kitovu changu  
Niondoke hapa kwangu  
Wangawa na vijikaratasi  
Si kwamba hapa si kwangu, siondoki

Katu  
Siondoki  
Sihitaji karatasi  
Niondoke hapa kwangu  
Yangu mimi ni ardhi hii  
Wala si makaratasi, siondoki

## **Maswali**

- a) Shairi hili ni la aina gani? Kwa nini (alama 2)
- b) Taja masaibu anayopitia mzungumzaji (alama 4)
- c) Eleza toni ya shairi hili (alama 2)
- d) Eleza muundo wa shairi hili (alama 3)
- e) Tambua matumizi ya mbinu ya usambamba (alama 2)
- f) Andika ubeti wa tano kwa lugha nathari (alama 4)
- g) Tambua idhini moja ya mtunzi (alama 1)
- h) Eleza maana ya maneno yafuatayo kama yalivyotumika katika shairi (alama 3)
  - (i) Karatasi
  - (ii) Nimesaki
- (iii) kitovu

## **2 SEHEMU B TAMTHILIA YA KIGOGO**

2. Uliona nini kwa huyo zebe wako ? Eti mapenzi!

- a. Eleza muktadha wa dondoo. (al. 4)
- b. Andika mbinu za lugha zinazojitokeza kwenye dondoo hili (al. 4)
- c. Taja hulka za mnenaji unajitokeza katika dondoo. (al. 2)
- d. Mwanamke ni kiumbe wa kukandamizwa. Thibitisha kauli hii ukirejelea tamthilia. (al. 10)

3. wa kurejelea tamthilia ya 'Kigogo ya Pauline Kea, onyesha jinsi ambavyo viongozi wengi katika nchi za kiasia wamejawa na tamaa. (alama 20)

## **SEHEMUC. RIWAYA YA CHOZI LA HERI (ASSUMPTA MATEI)**

4. "Kwa kweli ni hali ngumu hii"

Weka dondoo katika muktadha wake. (alama 4)

Ni hali gani yamsemewa inayorejelewa kwenye dondoo. (alama 16)

5) Ukabila ni tatizo sugu katika nchi nyingi za Kiafrika. Tetea kauli hii ukirejelea Chizi la Heri (al. 20)

## **Alifa Chokocho na Dumu Kayanda: Tumbo Lisiloshiba na Hadithi nyingine jibu swali la 6 au la 7**

6. Ukirejelea hadithi zifuatazo, eleza jinsi maudhui ya mapenzi na asasi ya ndoa yanavyojitokeza. (alama 20)

- a) Mapenzi ya kifaurongo
  - b) Masharti ya kisasa
  - c) Ndoto ya Mashaka
  - d) Mtihani wa maisha
- Au

## **Shibe inatumaliza : Salma Omar Hamad**

7. "Hiyo ni dharau ndugu yangu. Kwa nini kila siku tunakula sisi kwa niaba ya wengine?"

- a) Eleza muktadha wa dondoo hili. (alama 4)
- b) Eleza sifa za msemaji. (alama 6)
- c) Eleza jinsi viongozi wanavyokuwa wabadhirifu. (alama 10)

## **SEHEMU YA E: FASIHI SIMULIZI**

8a) Fafanua mchakato/fomula ya uwasilishaji wa vitendawili. (alama 4)

b) Linganisha naulinganue vitendawili na methali. (alama 10)

c) Toa sababu sita za kudidimia kwa fasihi simulizi. (alama 6)

# FORM 4 ENDTERM 2 EXAMS

## MATHEMATICS

### PAPER 1

TIME: 2 ½ HOURS

NAME..... ADM NO:.....

SIGN..... DATE;.....

**INSTRUCTION TO CANDIDATES**

- a) Write your name and Index number in the spaces provided above.
- b) Sign and write the date of examination in the spaces provided above.
- c) The paper consists of **two** sections. **Section I** and **Section II**.
- d) Answer **ALL** the questions in Section I and any **FIVE** questions in Section II.
- e) Show all the steps in your calculations, giving your answer at each stage in the spaces provided below each question.
- f) Marks may be given for correct working even if the answer is wrong.
- g) Non-programmable silent electronic calculators and KNEC Mathematical tables may be used except where stated otherwise.
- h) Candidates should answer the questions in English.
- i) This paper consists of 16 printed pages.
- j) Candidates must check the question paper to ascertain that all pages are printed as indicated and that no question(s) is/are missing.

**FOR EXAMINER'S USE**

**SECTION I**

1	2	3	4	5	6	7	8	9	10	11	12	13	14	15	16	Total

**SECTION II**

17	18	19	20	21	22	23	24	Total

Grand Total

**SECTION I (50 Marks)**

**Answer all the question in this section in the spaces provided**

1. If  $\vec{a} = \begin{pmatrix} -4 \\ 2 \end{pmatrix}$ ,  $\vec{b} = \begin{pmatrix} 1 \\ 2 \end{pmatrix}$ , and if  $2\vec{a} + k\vec{b} = \begin{pmatrix} -6 \\ 8 \end{pmatrix}$  determine the value of k. **(3 mks)**

2. Solve for x given that  $\frac{x-3}{3} = 4 - \frac{x-2}{2}$  **(3 mks)**

3. Solve the inequalities and represent information on a number line  $-7 + x < 3x + 2 < 4(x-5)$  **(3 mks)**

4. Evaluate using logarithms correct to 4 significant figures  $\sqrt{\frac{72.84 \times 1.64}{(1.52)^2}}$  **(4 mks)**

5. The sum interior angles of a regular polygon is 24 times the size of the exterior angle.
- (a) Find the number of sides of the polygon. **(3 mks)**

(b) Name the polygon. **(1 mk)**

6. If  $\tan \theta = \frac{8}{15}$  find the value of  $\frac{\sin \theta - \cos \theta}{\cos \theta + \sin \theta}$  without using a calculator or tables. **(3 mks)**

7. From the top of a cliff 90m high the angle of depression of a boat in the sea is  $26.2^\circ$ . Calculate how far the boat is from the foot of the cliff. **(3 mks)**

8. Make S the subject of the formula. **(3 mks)**

$$w = \sqrt[3]{\frac{s+t}{S}}$$

**FOR MARKING SCHEMES CALL/WHATSAPP 0746 222 000**

9. A town P is 200km west of Q, town R is distance of 80km on a bearing of  $049^{\circ}$  from P, town S is due East of R and north of Q. Determine the bearing of S from P. (use scale drawing 1cm rep 20km)

10. Calculate the area of triangle ABC for which AB=8cm and BC=6cm and BC=4cm. (3 mks)

11. Solve the pair of simultaneous equation using elimination method. (3 mks)

12. Solve for x given  $27 \times 3^x = (3^x)^x$  **(3 mks)**

13. Evaluate without using a calculator or a maths table.

$$\frac{\sqrt{144000}}{\sqrt[3]{216}} \quad \text{(3 mks)}$$

14. Expand and simplify **(2 mks)**

$$(x + 2y)^2 - (2y - 3)^2$$

15. The mass of solid cone of radius 14cm and height 18cm is 4.62kg. Find its density in  $\text{g/cm}^3$  **(3 mks)**

16. A minor arc of a circle subtends an angle of  $105^\circ$  at the centre of the circle. If the radius of the circle is 8.4cm. Find the length of the major arc. (Take  $\pi = \frac{22}{7}$ ) (3 mks)

**SECTION II (50 Marks)**

**Answer any five question in this section in the spaces provided**

17. The table below gives a field book showing the results of a survey of a section of a piece of land between A and H on the stream. All measurements are in metres.
- (a) Draw a sketch of the land. (2 mks)
- (b) Calculate the area of this piece of land. (8 mks)
18. The equation of a curve is given by  $y=x^3 -4x -3x$ .
- (a) Find the value of y when  $x= -1$  (1 mk)



(b) Determine the stationary points of the curve.

(5 mks)

(c) Find the equation of the normal to the curve at  $x=1$

(4 mks)

19. The table below gives the marks scored by a group of students in an exam.

Marks	15-19	20-24	25-29	30-34	35-39	40-44
No. of students	3	4	X	10	9	7

(a) Given that the mean mark was 32.0, find the value of  $x$ . (4 mks)

(b) State the modal class (1 mk)

(c) Determine median mark. (3 mks)

(c) The range (2 mks)

20. (a) Use a ruler and a pair of compasses only to construct a triangle ABC in which  $AB=4.6\text{cm}$ ,  $BC=5\text{cm}$  and  $\angle ABC=60^\circ$ . Measure AC. Drop a perpendicular from B to meet AC at N. Measure BN. Hence, calculate the area of triangle ABC. (7 mks)

(b) Find the area of the triangle below.

(3 mks)

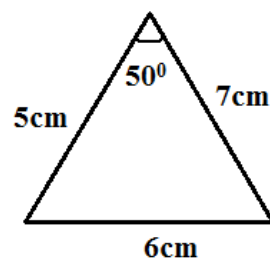

21. Three trees E, S and T are the vertices of a triangular field. R is 300m from S on a bearing of  $300^\circ$  and T is 480m directly south of R.

(a) Using scale of 1cm rep 60m draw a diagram to show the position of the trees. (3 mks)

(b) Use the diagram to determine

(i) The distance between T and S in metres

(2 mks)

(ii) The bearing of T from S

(1 mk)

(c) Find the area of the field in hectares to 1d.p

(4 mks)

22. In the fig below, O is the centre of a circle while radius is 6cm and PQ is 9cm.

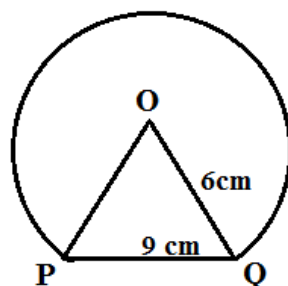

(a) Calculate the area of the major segment

(7 mks)

**FOR MARKING SCHEMES CALL/WHATSAPP 0746 222 000**

(b) Find the area of a triangle XYZ with sides 7cm, 9cm and 11cm long. (3 mks)

22. Draw the graph of function  $y = -x^2 + 4x - 1$  for  $-1 \leq x \leq 5$  (5 mks)

On the axes, draw the graph of  $y = 2x - 3$  (1 mks)

Use the graph to solve the following equations

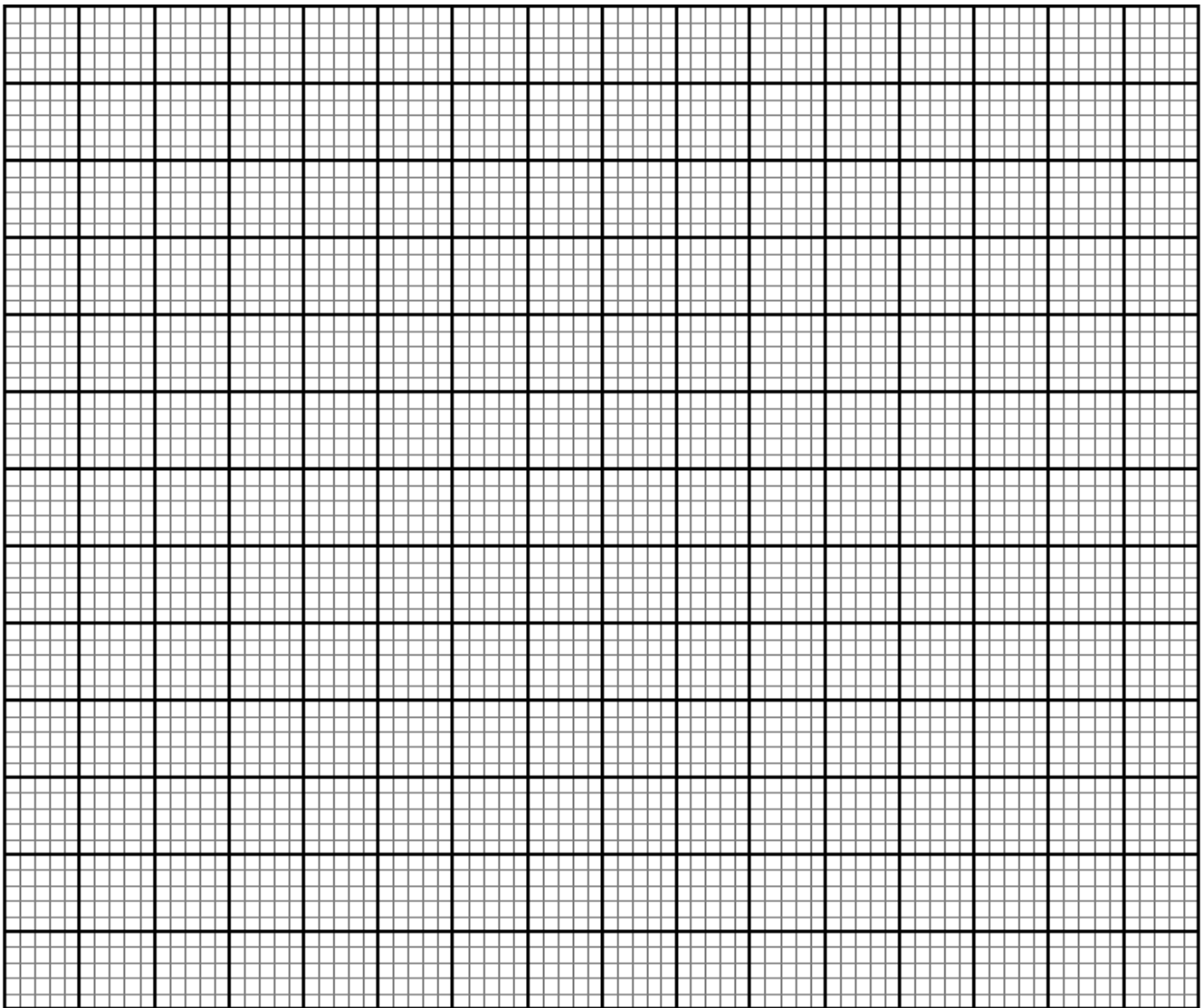

(a)  $x^2 - 4x + 1 = 0$

(2 mks)

(b)  $x^2 - 2x - 2 = 0$

(2 mks)

24. The diagram below shows an open bucket with top diameter 30cm and bottom diameter 20cm. The height of the bucket is 28cm.  $\left(\pi = \frac{22}{7}\right)$

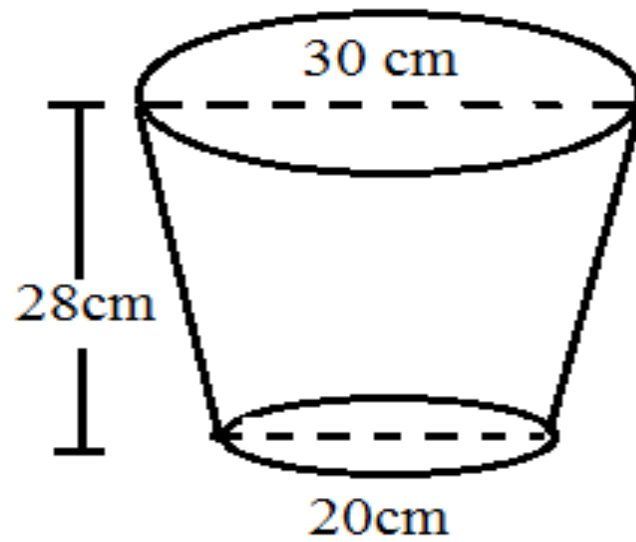

(a) The capacity of the bucket in litres. (5 mks)

(b) Area of the metal sheet required to make 100 such buckets. (5 mks)

# FORM 4 ENDTERM 2 EXAMS

## MATHEMATICS

### PAPER 2

TIME:2 ½ HOURS

NAME..... ADM NO:.....

SIGN..... DATE;.....

**INSTRUCTION TO CANDIDATES**

- a) Write your name and Index number in the spaces provided above.
- b) Sign and write the date of examination in the spaces provided above.
- c) The paper consists of **two** sections. **Section I** and **Section II**.
- d) Answer **ALL** the questions in Section I and any **FIVE** questions in Section II.
- e) Show all the steps in your calculations, giving your answer at each stage in the spaces provided below each question.
- f) Marks may be given for correct working even if the answer is wrong.
- g) Non-programmable silent electronic calculators and KNEC Mathematical tables may be used except where stated otherwise.
- h) Candidates should answer the questions in English.
- i) **This paper consists of 16 printed pages.**
- j) **Candidates must check the question paper to ascertain that all pages are printed as indicated and that no question(s) is/are missing.**

**FOR EXAMINER'S USE**

**SECTION I**

1	2	3	4	5	6	7	8	9	10	11	12	13	14	15	16	<b>Total</b>

**SECTION II**

17	18	19	20	21	22	23	24	<b>Total</b>

Grand Total



## **SECTION I (50 Marks)**

**Answer all the question in this section in the spaces provided**

1. Simplify  $\frac{\sqrt{5}}{\sqrt{5}-2}$  by rationalizing the denominator leaving the answer in the form  $a + b\sqrt{c}$  (3 mks)
  
  
  
  
  
  
  
  
  
  
2. Solve the equation  $\text{Log}_{10}(6x - 2) - 1 = \text{Log}_{10}(x - 3)$  (3 mks)
  
  
  
  
  
  
  
  
  
  
3. Find the percentage error in the calculation of volume of a sphere of radius 7.2cm. (4 mks)
  
  
  
  
  
  
  
  
  
  
4. A point P divides the line RT in the ration -2:5. Find the coordinates of P given R(3,1) and T (6, -5). (3 mks)

5. Make A the subject of the formula  $-B = \sqrt{\frac{A^2 + 2C}{A^2}}$  (3 mks)

6. In what ratio will coffee grade A costing shs 90 per kg are mixed with coffee grade B costing sh 60 per kg so that a profit of 25% is realized by selling the mixture at sh 80 per kg. (3 mks)

7. A transformation is represented by the matrix  $R = \begin{pmatrix} x & -3 \\ 2 & 5x \end{pmatrix}$ . R maps an object of area  $10\text{cm}^2$  onto an image of area  $110\text{cm}^2$ . Find the possible values of x. (3 mks)

8. Find the value of x in the figure below. (5 mks)

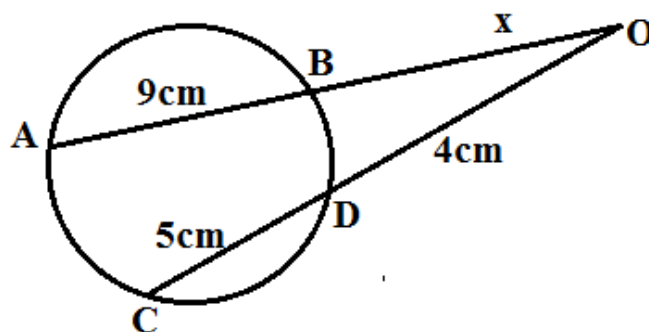

9. Write down the first four terms of the expansion of  $(1+3x)^9$ . Hence find the value of  $(1.003)^9$  correct to 5 s.f (4 mks)
10. Solve the equation  $\sin \theta = \frac{\sqrt{3}}{2}$  for  $0^\circ \leq \theta \leq 360^\circ$  (2 mks)
11. The equation of a circle is given by  $x^2 + 4x + y^2 - 4y - 4 = 0$ . Determine the centre and radius of the circle. (3 mks)
12. A man sold a motor cycle at sh 84000. The rate of depreciation was 5% per annum. Calculate the value of the motor cycle after 3 yrs to 1 d.p (3 mks)

13. Use logarithms tables to evaluate  $3\sqrt{\frac{36.15 \times 0.02575}{1.958}}$  (4 mks)

14. The position of a point A ( $47^{\circ}\text{N}$ ,  $25^{\circ}\text{E}$ ) and B( $47^{\circ}\text{N}$ ,  $70^{\circ}\text{E}$ ). Find the distance between A and B in km. Take radius of earth as 6370km. (3 mks)

15. A quantity Y is partly constant and partly varies inversely as X. Given that  $Y=10$  when  $X=1.5$  and  $x=1.5$  and  $Y=20$  when  $X=1.25$  find the equation connecting x and y.

16. A bag contains 5 red, 4 white and 5 blue beads. Three beads are selected at random without replacement find the probability that the beads selected were red, white and blue in that order. (3 mks)

**SECTION I (50 Marks)**

**FOR MARKING SCHEMES CALL/WHATSAPP 0746 222 000**

**Answer any 5 question in this section in the spaces provided**

17. The table below shows income tax rates.

Monthly taxable pay in KE	Rate of tax in ksh per pound
1-435	2
436-970	3
971-1505	4
1506-2040	5
excess over 2040	6

Mr. Munira earns a monthly salary of ksh 30000 and taxable allowances amounting to 5980.

(a) Calculate his taxable income in KE (2 mks)

(b) Calculate his monthly tax (4 mks)

(c) If he entitled to a tax relief of ksh 800, determine his net tax. (1 mk)

(d) If he pays NHIF of sh 320 and NSSF of h 240 per month fluid his net salary. (3 mks)

18. The figure below is a circle centre O. ABT is a tangent to the circle at B and chord CD =4.5cm, BD = 3.6cm and DT=8cm

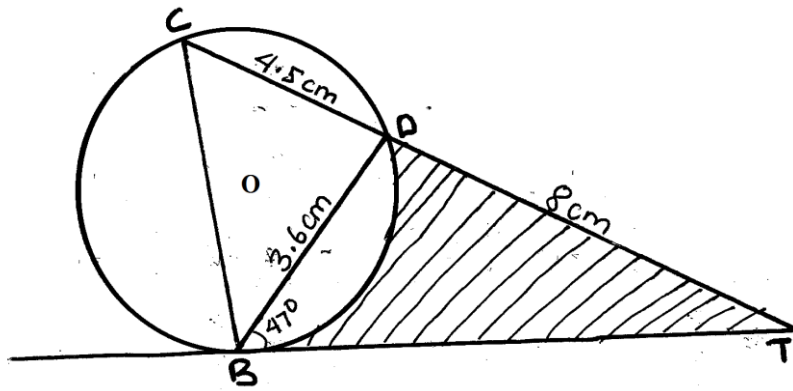

Calculate

(a) The length of BT (3mks)

(b) The radius of the circle (3 mks)

(c) The area of the shaded region (4 mks)

19. The diagram below shows triangle OAB in which N is the midpoint of AB and M is a point on OA such that  $OM:MA = 2:1$ . Lines ON and BM meet at X such that  $OX = hON$  and  $MX = kMB$

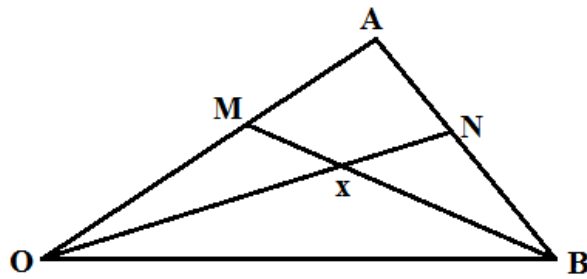

(a) Gives that  $\vec{OA} = \underline{a}$  and  $\vec{OB} = \underline{b}$  express in terms of  $\underline{a}$  and  $\underline{b}$

(i)  $\vec{AB}$  (1 mk)

(ii)  $\vec{ON}$  (1 mk)

(iii)  $\vec{BM}$  (2 mks)

(b) By expressing  $\vec{OX}$  in two different ways, determine the values of h and k (6 mks)

20. (a) Complete the table below giving your values correct to 1d.p (2 mks)

$X^\circ$	0	30	60	90	120	150	180
$\cos 2x$	1.0		-0.5	-1.0		0.5	
$\sin (x+30)^\circ$	0.5		1.0		0.5	0	

(b) Draw on the same axes the two graphs for  $0^\circ \leq x \leq 180^\circ$  (4 mks)

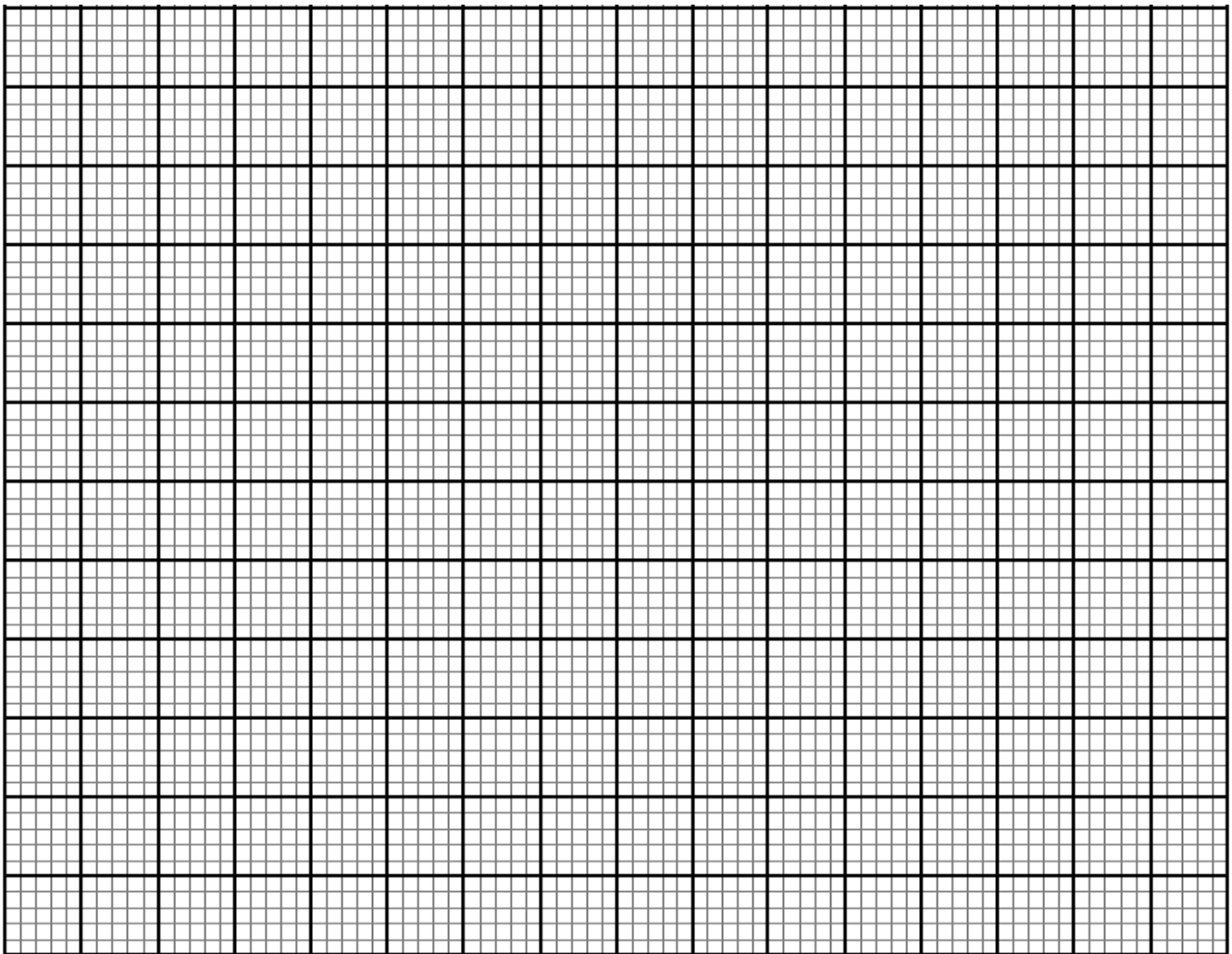

(c) Find the period of  $y = \cos 2x$  (1 mk)

(d) Solve the equation

(i)  $\sin(x+30) = \cos 2x$  (2 mks)

(ii)  $\cos 2 = 0.6$  using the two graph (1 mk)

21. The table below shows the distribution of masses of pupils in a contain academy.

Mass(kg)	20-24	25-29	30-34	35-39	40-44	45-49	50-54	55-59	60-64	65-69
No. of pupils	1	5	9	11	20	20	19	8	4	3

(a) State the class size (1 mk)



(b) Using 47 as the assumed mean calculate,

(i) The mean mass

**(4 mks)**

(ii) The standard deviation the masses.

**(5 mks)**

**22.** (a) The first term of an Arithmetic progression is 2. The sum of the first 8 terms of the AP is 156.

(i) Find the common difference of the AP

**(2 mks)**

(ii) Given that the sum of the first  $n$  terms of the AP is 416 find  $n$ .

**(2 mks)**

**FOR MARKING SCHEMES CALL/WHATSAPP 0746 222 000**

- (b) The third, fifth and eight terms of another AP form the first three consecutive term of a geometric progression (G.P). If the common difference of the AP is 5. Find
- (i) The first term of the GP (4 mks)

- (ii) The sum of the first 9 terms of the GP correct to 4 s.f. (2 mks)

23. The figure below shows a right angled pyramid with vertex V and edges VA, VB, VC, VD each 10cm long. The base ABCD is a rectangle of length 8cm and width 4cm and M is the midpoint of CV.

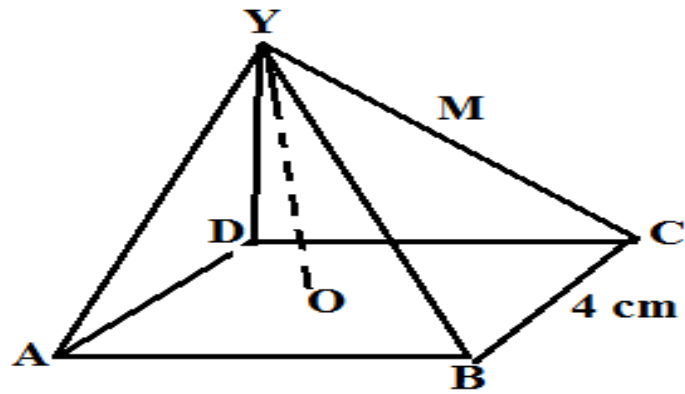

Calculate:

(i) The vertical height of the pyramid (3 mks)

(ii) The angle between the planes VBC and the base ABCD (2 mks)

(iii) The angle between the planes VBC and VAD (3 mks)

(iv) The volume of the pyramid (2 mks)

24. A particle moves in a straight line such that its displacement from A after time  $t$  seconds is given by the equation  $S=2t^3 - 7t^2 + 7t - 2$

Determine;

(a) Its displacement when  $t=3$  sec (2 mks)

**FOR MARKING SCHEMES CALL/WHATSAPP 0746 222 000**

(b) Its velocity when  $t=5$  **(3 mks)**

(c) The values of  $t$  when the particle is momentarily at rest. **(3 mks)**

(d) The acceleration when  $t=2$  **(2 mks)**

# FORM 4 ENDTERM 2 EXAMS

## COMPUTER

PAPER 1

THEORY

TIME:2 ½ HOURS

NAME..... ADM NO:.....

SIGN..... DATE;.....

### INSTRUCTIONS TO CANDIDATES

- Write your name and index number in the spaces provided above.
- This paper consists of **TWO** sections A & B.
- Answer **ALL** the questions in section A.
- Answer question **16** and any other **THREE** questions from section B.
- All answers should be written in the spaces provided on the questions paper.

### For Official Use Only

Section	Question	Candidate's score
A	1-15	
B	16	
	17	
	18	
	19	
	20	
Total score		

**SECTION A (40 AMRKS)**

**ANSWER ALL THE QUESTIONS IN THIS SECTION.**

1. (A) What is an embedded computer? **(1 mk)**

.....  
.....

(B) State the main component that formed the basis for second generation computers. **(1 mk)**

.....  
.....

2. The diagram below shows electronic pathways on a Section of a motherboard. Study the Illustration and answer the question that follows.

(a) What name is given to the pathway? **(1 mark)**

.....  
.....

b) Explain three types of the pathways in (a) above. **(3 marks)**

.....  
.....  
.....  
.....

3 (A) Explain how an operating system such as Microsoft windows ensures that there is no hardware conflict. **(2 marks)**

.....  
.....  
.....

4 Explain how the operating system controls the following resources **(3marks)**

i) Processor

.....

ii) Main memory

.....

iii) Input and output devices

.....

(C') Give one function of a main frame operating system hich you ould not expect to flnd in the operating system of a micro—computer.

(liiik)

: çL

t.

5 (A) Define the term firewall (1mk)

.....  
.....

B) State three ways of ensuring efficient backup of data (2Marks)

.....  
.....

6. A) Outline the three program control structures (1½Marks)

.....  
.....  
.....  
.....

B.) Give three types of selection construct (1½Marks)

.....  
.....  
.....  
.....

C.) Define the term encapsulation as applied in object oriented programming (2Marks)

.....  
.....

7. A) What is Hypertext Mark Up Language? (1 Mark)

.....  
.....

B.) Why should a program be documented in each and every stage? **(1mark)**

.....  
.....

8. A) A student was reading through a daily newspaper on different types of data communication media. As a computer student, how will you assist him define the term data communication media? **(1**

**Mark)** .....

.....

B) Differentiate between share level security and user level security as used in network security. **(2mks)**

.....  
.....  
.....

(C) What are the differences between Token ring topology and Ethernet **(2mks)**

.....  
.....  
.....

9. Describe the term biometric analysis **(1Mark)**

.....  
.....

10. Give two uses of spreadsheets in a government office concerned with carrying out national census **(2mks)**

.....  
.....  
.....



11. (A) You may have come across the term 'Garbage in, Garbage out' (GIGO). Explain the meaning of this statement with regard to data processing. **(2 marks)**
- .....
- .....
- .....
- (B) Name four examples of application software. **(2mks)**
- .....
- .....
- .....
- .....
- (C) What is the difference between Real data type and an Integer data type as used in programming? **(2mks)**
- .....
- .....
- .....
- (D) Differentiate between a source code and an object code. **(2mks)**
- .....
- .....
- .....
12. State three changeover strategies that can be used to move from the old system to a new one. **(3s)**
- .....
- .....
- .....
- .....
13. Name four data types used in spreadsheets. **(2 Marks)**
- .....
- .....
- .....
- .....
14. What is a chart wizard in spreadsheets? **(1 Mark)**
- .....
- .....
15. (a) What is a peripheral device? **(1mks)**

.....  
.....

**SECTION B (60MKS)**

**ANSWER QUESTIONS 16 (COMPULSORY AND ANY OTHER 3 QUESTIONS IN THIS SECTION)**

16. (a) Design a flowchart for a simple program that can be used to categorize people according to age. If the person is above or equal 18 years, output "Adult" otherwise output "Young" (8mks)

- (b) What is the difference between looping and selection. (2mk)

.....  
.....  
.....

- (c) Name the stage of program development cycle when:  
(i) A user guide would be written (5mks)

.....

(ii) A programmer dry-run the code

.....

(iii) System charts would be drawn

.....

(iv) Staff training is done

.....

(v) Acceptance of problem existence

.....

7. The information below is maintained by the patron of wildlife club in a school. Study it and answer the questions that follow.

Name Class Admission number Membership number Group

Name	Class	Admission number	Membership number	Group
Aruya	4E	3740	S001	Serengeti
Mercy	3E	3802	T001	Tsavo
Ominde	2N	3949	T003	Tsavo
Caro	4W	3762	M001	Mara
Miriam	3N	3800	A001	Amboseli
Zach	2E	3925	S002	Serengeti
Antony	2W	3926	N001	Nairobi
Januaris	4N	3946	AB001	Aberdare
Pauline	3E	3805	T002	Tsavo
Mary	1W	4029	N002	Nairobi
Daniel	IN	4013	M002	Mara

a) Describe the field values records and file (3 marks)

.....  
.....  
.....  
.....

b) State the most appropriate data type for the fields

i) Admission number (1mark)

.....  
.....

ii) Membership number (1 mark)

.....  
.....  
appropriate primary key for the list (1mark)  
.....  
.....

c) State most

d) If a database was to be created for the list forms, Tables, queries and reports are likely to be used

i) State the purpose of each of the objects (4 marks)

.....  
.....  
.....  
.....  
.....  
.....

ii) Which objects cannot be used to store date in the list (3 marks)

.....  
.....  
.....  
.....  
.....  
.....

e) i) How many field values are in the list (1 mark)

.....  
.....

ii) How many records are in the list (1 mark)

.....  
.....

18. (a) Consider the topologies demonstrated in the diagram below.

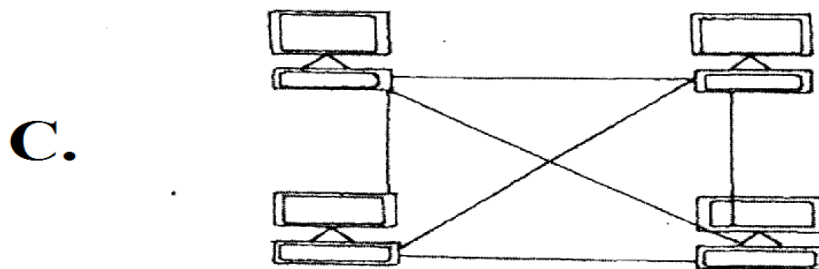
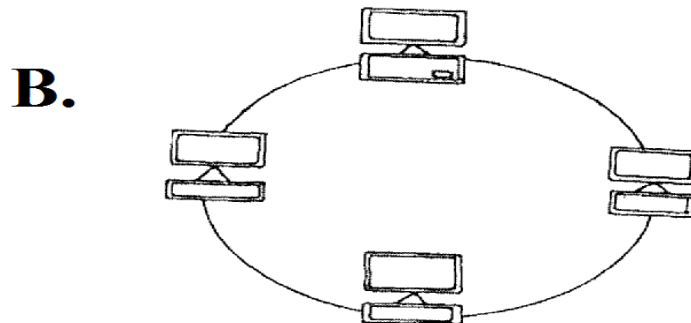
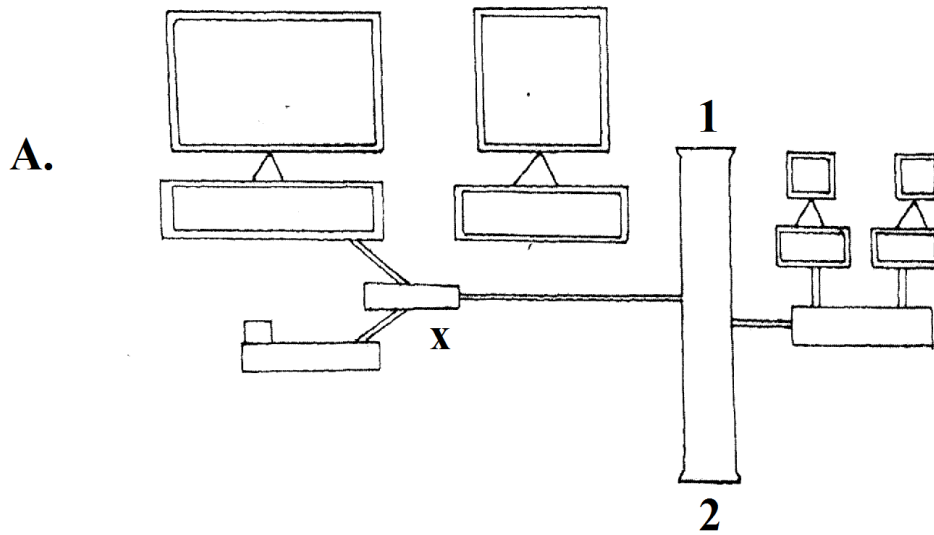

(i) Identify the network topologies (3marks)

A.....

B.....

C.....

(ii) In topology A, identify the network device that should be at the end point 1 and 2 (1mark)

.....  
 .....

(iii) Which of the above topologies is likely to be used in a wide area network(1mark)

.....  
 .....

..... (iv)  
Highlight three disadvantages of topology B. (3 marks)

.....  
.....  
.....

(v) Identify the device labeled X in topology A (1 mark)

.....

..... (b) State two main  
classes of network software (2marks)

.....  
.....

..... (c) Briefly describe  
the following as used in networking (4marks)

i) Repeaters .....

.....  
.....

ii) Network hub

.....

iii) Fibre Optic

cables .....

.....

iv) Network interface card (NIC)

.....

.....

9. a) Compute the value of x in the following expressions

(i)  $24.35_{10} = X_2$  (3mks)

(ii)  $6AB_H = X_{10}$  (2mks)

(b) Using twos complements compute the following using 8 bits binary (4mks)

$25_{10} - 20_{10}$

c) Subtract the following binary numbers using the One's Complement method. (3mks)  
 $(11101)_2 - (1010)_2$

d) Convert  $6057_8$  to Hexadecimal. (3mks)

20. a) i) Define a system. (1mk)

.....  
.....

ii)

Explain system entropy. (1 mk)

.....  
.....

b) State three circumstances that can lead to development of information systems. (3 mks)

.....  
.....  
.....

c) Distinguish parallel changes over from straight change over as used in system implementation. (2 mks)

.....  
.....  
.....

d) Discuss two fact finding methods. (4 mks)

.....  
.....  
.....  
.....

e) Differentiate an open system from a closed system.

(2 mks)

.....  
.....  
.....

f) List two responsibilities of a system analyst.

(2 mks)

.....  
.....



# FORM 4 ENDTERM 2 EXAMS

## COMPUTER

PAPER 2

PRACTICAL

TIME:2 ½ HOURS

NAME..... ADM NO:.....

SIGN..... DATE;.....

### INSTRUCTIONS TO CANDIDATES

- (a) *Type your name and index number at the top right hand corner of each printout.*
- (b) *Write your name and index number on the compact disk.*
- (c) *Write your name and version of software used for each question in the answer sheet..*
- (d) ***Passwords should not be used while saving in the compact disk.***
- (e) *Answer All questions.*
- (f) *All questions carry equal marks.*
- (g) *All answers **must be saved** in your compact disk*
- (h) *Make a printout of the answers on the Answer sheets provided.*
- (i) *Hand in all your printouts and the compact disk.*
- (j) *This Paper consists of 4 printed pages. Candidates should check the question paper fully to ensure that all pages are printed as indicated and that no question is missing.*

1. Modern Technology Electronics LTD wants to computerize her operations in order to enhance her service delivery. All clients' data will be held in a database called MODERNBASE.

**FOR MARKING SCHEMES CALL/WHATSAPP 0746 222 000**

Required:

- (a) In **MODERNBASE** database, create two related tables namely: **CLIENTS** and **PRODUCTS** using the details given below. (10mks)

Client

- Client ID
- Company Name
- Location
- Postal Address
- Telephone

Product

- Category ID
- Product Description
- Unit Price
- Quantity

- (b) Make the client ID and category ID the primary keys in the two respective tables. (4mks)

- (c) The company wants to keep track of each item ordered by each client.

Create a relationship between each client and product tables and reinforce the referential integrity. (4mks)

- (d) Create columnar forms for each of the tables. Save the form as **Client Entry** and **Product Entry**. (10mks)

- (e) Mary Atieno ordered for the items shown in the product ordered table. Use the Client Entry and Product Entry forms to enter the following records. (8mks)

Client Table

Client ID	Client Name	Postal Address	Location	Phone
MTE001	Emmanuel Nguya	540	Kiambu	200878
MTE007	Mary Atieno	4080	Migori	245350
MTE009	Jimmy Wasike	54	Kakamega	567049
MTE016	Simon Muoki	3400	Embu	459900
MTE023	Susan Cheronon	460	Eldoret	690650

Product Table

Category ID	Product Description	Unit Price	Quantity
TV001	21" LG TV	16000	8
DV003	Sony DVD Player	4500	20
TV004	14" JVC TV	11000	22
RD003	Samsung Radio Player	4700	8
TV007	14" ZEC TV	8200	4

- (f) Create a query that displays the Client ID, Client Name, Location, Product, Description, Quantity, Unit Price and a calculated field **Amount** being the product of Quantity and Unit price. Save the Query as Item Query. (8mks)

- (g) Generate a report based on **Hem Query**. Save the report as **Sales Report**. (2mks)

(h) **Print**

- (i) Two tables in design view: Client and Product.

- (ii) Two forms in form view

- (iii) Hems Query

- (iv) Sales Report. (4mks)

2. TumainiTechrocrats Electronics LTD deals with sales of three types of electronic goods namely: Television sets, Radio system and DVD players.

**FOR MARKING SCHEMES CALL/WHATSAPP 0746 222 000**

Below is a table showing details of April 2007 sales.

Modern Technocrats Electronic LTD.							
Sales as per 30 <sup>th</sup> April 2007							
CATEGORY CODE	Type	Item Description	Unit Price	Sold	Sub total	Tax	Net amount
TV001	TV	21" LG TV	16000	8			
TV003	TV	38" Samsung TV	60000	2			
RD001	Radio	JVC 3CD charger	21000	12			
DV001	Radio	Philips DVD player	5500	6			
TV004	TV	14" JVC TV	11000	22			
DV002	Radio	LD D20VD player	6200	18			
TV005	TV	21" Sony TV	15800	14			
DV003	DVD	Sony DVD player	4500	20			
RD002	Radio	Panasonic Radio player	3200	30			
RD003	Radio	Samsung Radio player	4700	8			
TV007	TV	14" ZEC TV	8200	4			
DV001	Radio	Panasomic DVD player	6500	16			
Tax rates			TV	15%			
			DVD	12%			
			RADIO	8%			

Required:

- (a) Enter the data in a work sheet and save it as **A:\MODERNTEC** (18mks)
- (b) Format the worksheet as follows:
- (i) Centre the title across columns. (2mks)
  - (ii) The text should be Aerial, 18 points, Bold and Centred within a box. (2mks)
  - (iii) Column headings to be wrapped within the cells and centred horizontally and vertically. (2mks)
  - (iv) The unit price to be in *two decimal* places and currency prefix *Ksh.* (4mks)

**FOR MARKING SCHEMES CALL/WHATSAPP 0746 222 000**

- (c) Use the appropriate cell references to calculate
- (i) The subtotal, rounded to two decimal places.
  - (ii) The TAX is based on the type of item.  
Use the rates given in the table above to calculate tax payable on each item sold. **(2mks)**
  - (iii) The net amount, which is the subtotal less tax. **(2mks)**
- (d) Sort the worksheet in ascending order according to category. **(2mks)**
- (e) Calculate the subtotals and grand totals for the three types of electronic goods. **(6mks)**
- (f) On a separate sheet, create a bar graph that compares sales for the three types of electronic goods. Label it appropriately. **(8mks)**
- (g) Print the worksheet showing all formulae used instead of values and the graph. **(2mks)**

# FORM 4 ENDTERM 2 EXAMS

## HOMESCIENCE

### PAPER 1

TIME:2 ½ HOURS

NAME..... ADM NO:.....

SIGN..... DATE;.....

#### INSTRUCTION TO CANDIDATES

- (a) Write your name and index number in the spaces provided
- (b) This paper consists of three section A, B and C
- (c) Answer all the questions in section A and B
- (d) Answer any two questions in section C
- (e) Answer should be written in the spaces provided in this booklet

#### FOR EXAMINER'S USE ONLY

SECTION	QUESTIONS	MAXIMUM SCORE	CANDIDATE'S SCORE
A	1 – 14	40	
B	15	20	
C		20	
		20	
		20	
	TOTAL	100	

**Section A: 40 Marks**

**Answer all the question in the spaces provided**

1 State two methods of softening hard water at home. (2 mks)

.....  
.....  
.....

2. List any disadvantages of buying a house. (3 mks)

.....  
.....  
.....

3. Differentiate between the following (4 mks)

(a) Garnishing and decorating

.....  
.....

(b) Herbs and sspices

.....  
.....

4. Explain why margarine may not be the best fat to use for deep frying. (4 mks)

.....  
.....  
.....

5. Mention here disadvantages of hard water. (3 mks)

.....  
.....  
.....

6. State two reasons for one becoming a vegetarian. (2 mks)

.....  
.....

7. Give three uses of a cross way strip. (3 mks)

.....  
.....  
.....

8. Identify three sewing notions that may be needed for a blouse. (3 mks)

.....  
.....  
.....  
.....

9. List two advantages and two disadvantages of home confinement. (4 mks)

.....  
.....  
.....  
.....

10. List two uses of old newspaper in cleaning of the home. (2 mks)

.....  
.....

11. Mention two qualities of a container used to store drinking water. (2 mks)

.....  
.....

12. Name the main areas of a kitchen work triangle. (3 mks)

.....  
.....  
.....  
.....

13. Give three functions of the skin. (3 mks)

.....  
.....  
.....  
.....

14. Give two functions of a shank. (2 mks)

.....  
.....

## Compulsory

15. Your brother and his friends are coming to visit you over the weekend. Briefly describe how you would

- (a) Launder a white cotton table cloth to use on the occasion. (14mks)

.....

.....

.....

.....

.....

.....

.....

.....

.....

.....

.....

.....

.....

.....

.....

.....

.....

.....

.....

.....

.....

.....

.....

.....

.....

.....

.....



.....

.....

.....

.....

.....

.....

.....

.....

.....

.....

.....

.....

.....

.....

.....

.....

.....

.....

.....

.....

.....

.....

(b) Clean one of the water glasses to be used during the function. (6 mks)

.....

.....

.....

.....

.....

.....

.....

.....

.....

.....

.....

.....

.....

.....

.....

.....

.....

.....

.....

.....

.....

.....

**Section C: 40 marks**

**Answer any two of the three questions in this section**

16. (a) Identify four pieces of information that should be included in a receipt. (4 mks)







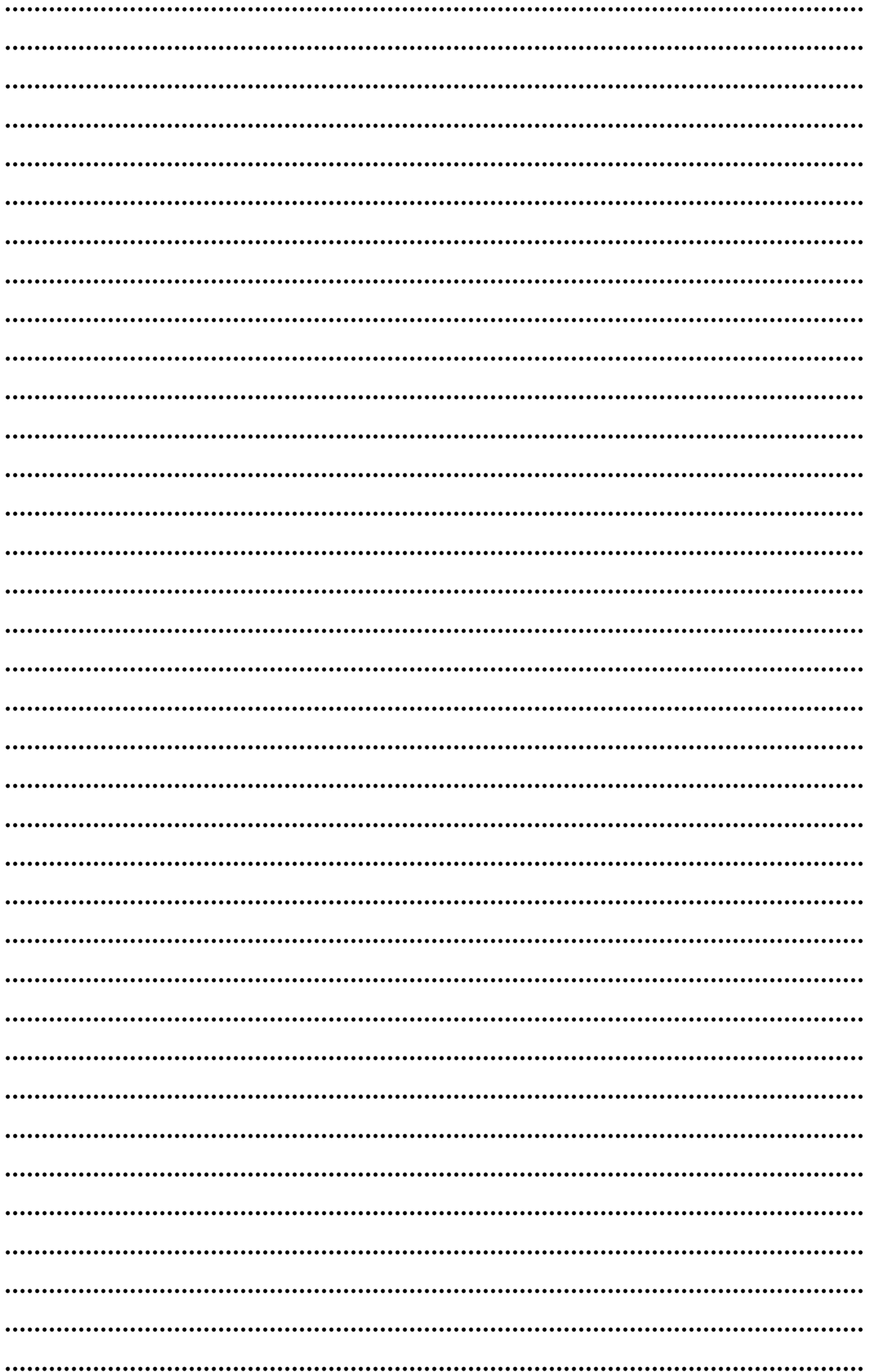



# FORM 4 ENDTERM 2 EXAMS

## HOMESCIENCE

### PAPER 2

### CLOTHING AND CONSTRUCTION

TIME:2 ½ HOURS

NAME..... ADM NO:.....

SIGN..... DATE;.....

#### INSTRUCTION'S TO CANDIDATES

- *This paper consists of 4 printed pages.*
- *Candidates must check the question paper to ascertain that all pages are printed as indicated and that no question(s) is/are missing*
- *Candidates must use machine stitches unless otherwise indicated*
- *Hand stitches will not be marked.*

## **GIRLS SKIRT**

A pattern of a girls skirt is provided. You are advised to study the sketches, instructions and layout carefully before you begin your work.

### **MATERIALS PROVIDED**

1. Pattern pieces
  - A. Skirt back
  - B. Yoke (Front)
  - C. Lower skirt (front)
  - D. Front waist band
  - E. Back waist band
  - F. Frill
2. Plain lightweight cotton fabric 56cm long by 90cm wide
3. Sewing thread to match the fabric
4. One large envelope

### **THE TEST**

Using the material provided, cut out and make the LEFT HALF of the girl's skirt to show the following processes;

- a) Cutting out
- b) Making of the dart at the back skirt
- c) Joining of the yoke front to the lower skirt front using an overlaid seam. **DO NOT TRIM NEATEN HALF OF THE SEAM USING LOOP STICHES**
- d) Attaching of the frill to the lower skirt front using a plain seam  
**LEAVE THE GATHERING STICHES AND DO NOT TRIM THE SEAM ALLOWANCE.**
- e) Making of the skirt side seam from the yoke to the hem line using an open seam
- f) Attaching of the front and back waist bands and holding them in place using tacking stitches.
- g) Making of the worked button hole.
- h) Omit the management of the skirt hem.
- i) Overall presentation

At the end of the examination, firmly sew onto your work, on a single fabric, a label bearing your name and Index number. Remove the needle, pins and loose threads from your work. Fold your work neatly and place it in the envelope provided. Do not put scraps of fabric in the envelope. Do not seal the envelope.



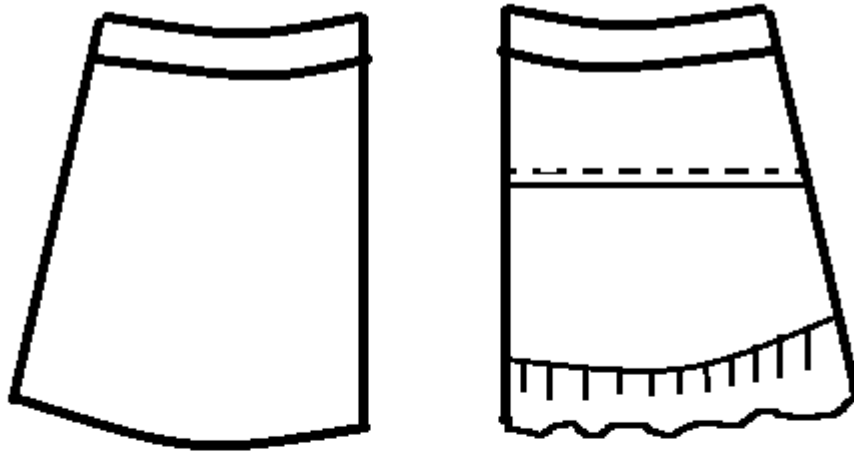

LAYOUT (Not drawn to scale)

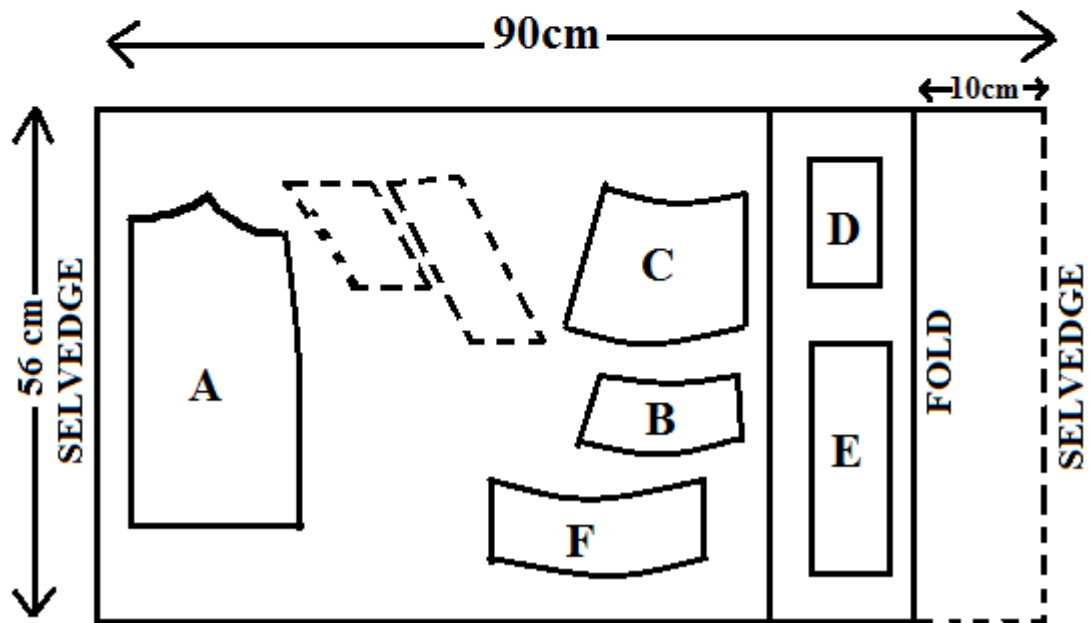

**FOR MARKING SCHEMES  
CALL/WHATSAPP 0746 222 000**

**MWALIMU AGENCY**

***FOR MARKING SCHEMES CALL/WHATSAPP 0746 222 000***