

F3 ENDTERM 2 EXAMS

ALL SUBJECTS

SERIES 1

SUBJECTS COMPILED:

Maths, English, Kiswahili, Biology, Chemistry, Physics, History, CRE, Geography, Agriculture, Business Studies and Computer.

A Collection of well-organized standard updated End of Term Two Test Examinations for our Current Form 3 Students in all Schools in Kenya.

SERIES 1

For marking schemes

CALL/TEXT/WHATSAPP 0746 222 000

MWALIMU AGENCY

FORM 3 ENDTERM 2 EXAMS

BIOLOGY

PAPER 1

TIME:2 HOURS

NAME..... ADM NO:.....

SIGN..... DATE;.....

INSTRUCTIONS

Answer all the questions in the spaces provided

1. The diagram below is that of a gill of a fish.

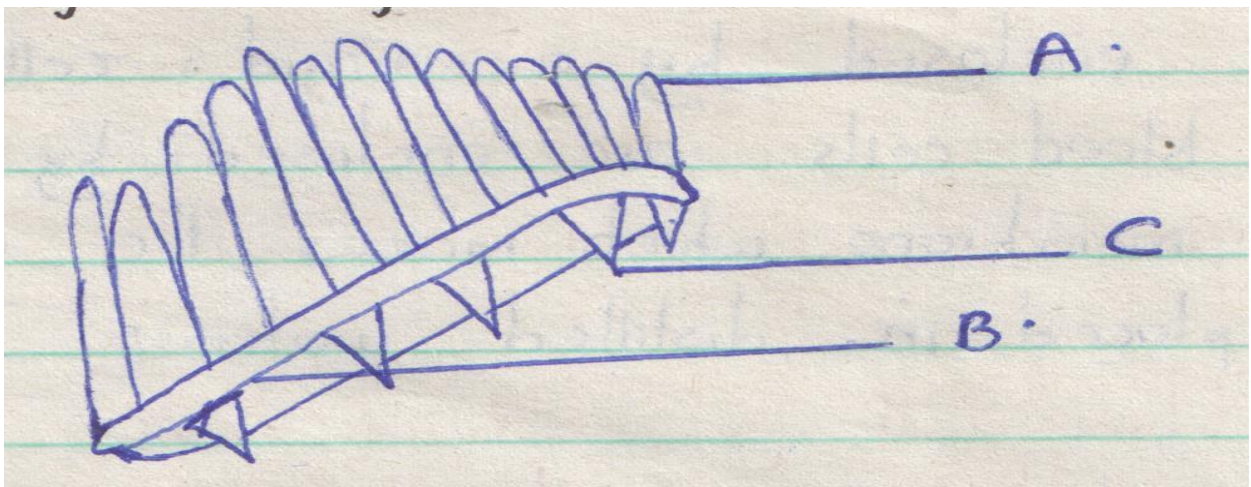

a) Name the parts labeled A and B. (2mks)

.....

.....

.....

b) State the function of part labeled C. (1mk)

.....

.....

c) Explain how structure labeled A is adapted to its function. (2mks)

FOR MARKING SCHEMES CALL/WHATSAPP 0746 222 000

.....
.....
.....

2. (a) Give the products of aerobic respiration in plants and animals. **(3mks)**

.....
.....
.....

(b) Name two factors that affect the rate of respiration. **(2mks)**

.....
.....
.....

3. Explain why red blood cells burst when placed in distilled water while plant cells remain intact. **(3mks)**

.....
.....
.....

4. Distinguish between diffusion and osmosis. **(2mks)**

.....
.....
.....

5. A form three student came across two different types of fruits which are described as follows:

Fruit A

Has free central placentation, hard epicarp and fibres air-filled mesocarp.

Fruit B

Has axile placentation, fleshy mesocarp and brightly coloured epicarp.

FOR MARKING SCHEMES CALL/WHATSAPP 0746 222 000

a) Suggest the possible agent of dispersal of each type of fruit. (2mks)

.....
.....
.....

6. A student examining pond water came across a certain living organisms which he drew as shown below.

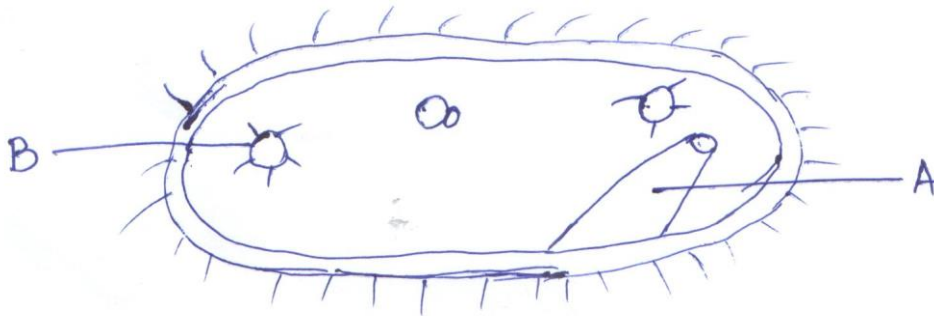

i) Identify the organism shown above. (1mk)

.....
.....

ii) State the kingdom of the above organism. (1mk)

.....
.....

iii) Name the structure labeled A. (1mk)

.....
.....

iv) State the function of the part labeled B. (1mk)

.....
.....

7. Give the role of the following hormones during menstrual cycle. (3mks)

a) Follicle stimulating hormone.

.....
.....

b) Oestrogen.

.....
.....

c) Luteinizing hormone.

.....
.....

8. During a surgical operation, a doctor accidentally cut two blood vessels A and B. Out of blood vessel A, blood was spurting out while through blood vessel B, blood was flowing smoothly.

i) Identify blood vessels A and B. **(2mks)**

.....
.....

9. What are the disadvantages of sexual reproduction? **(3mks)**

.....
.....
.....
.....

10. During cold weather, very small mammals eat more than their own weight of food per day whereas large mammals eat food which is only a small fraction of their weight. Give an explanation for this. **(3mks)**

.....
.....
.....
.....
.....
.....

11. State the function of the following cell organelles. **(3mks)**

a) Lysosomes.

.....
.....

b) Ribosomes.

.....
.....

c) Golgi apparatus.

.....
.....

12. Pregnancy would persist after the expiry of the fifth month of pregnancy even if the two ovaries are surgically removed from the body of female individual. Give an account for this. **(2mks)**

.....
.....
.....
.....

13. List two main branches of biology and for each, give a definition. **(2mks)**

.....
.....

14. What is the role of vascular bundles in plant nutrition? **(3mks)**

.....
.....

15. What do you understand by the term double fertilization in flowering plants? **(2mks)**

.....
.....

16. Define the following terms as used in ecology. **(3mks)**

i) Carrying capacity.

.....
.....

ii) Biosphere.

.....
.....

iii) Ecological niche.

.....
.....

17. Distinguish between intra-specific and inter-specific competition. **(2mks)**

.....
.....
.....
.....

18. (i) Name the process through which free atmospheric nitrogen is converted into nitrates. **(1mk)**

.....
.....

(ii) Name the bacteria found in root nodules of leguminous plants. **(1mk)**

.....
.....

(iii) What is the role of bacteria named (a) above. **(1mk)**

.....
.....

19. In a capture-recapture exercise to estimate population size of dragon flies on a stretch of rivers, 250flies were first caught and marked. Two days later 500 flies were caught in the second capture and out of this, 50 flies had marks on their bodies. Estimate the population size of the flies. (show your working)

(3mks)

20. The diagram below shows a stage of a certain type of cell division.

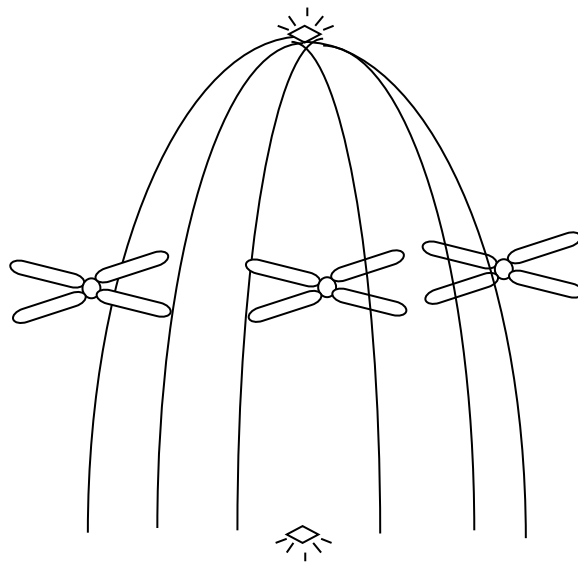

a) Identify the stage and type of the cell division the above cell is undergoing.

(2mks)

.....
.....

b) State two importance of the above type of cell division.

(2mks)

.....
.....

21. (a) What is placentation?

(1mk)

.....
.....

(b) Give three types of placentation.

(3mks)

.....
.....

22. Identify four ways through which the HIV/AIDs virus is transmitted.

(4mks)

.....
.....
.....
.....

23. State the mode of asexual reproduction in;

(3mks)

a) Yeast.

b) Amoeba.

c) *Rhizopus* species.

24. (a) Name one defect of circulatory system in humans.

(1mk)

.....
.....

(b) State three functions of blood other than transport.

(3mks)

.....
.....
.....
.....

25. What do you understand by the term oxygen debt? **(2mks)**

.....
.....

26. List any two distinguishing features of class arachnida. **(2mks)**

.....
.....

27. Give the name used to refer to fruit development without fertilization. **(1mk)**

.....
.....

28. During which phase of meiosis does crossing over occur? **(1mk)**

.....
.....

FORM 3 ENDTERM 2 EXAMS

BIOLOGY

PAPER 2

TIME:2 HOURS

NAME..... ADM NO:.....

SIGN..... DATE;.....

INSTRUCTIONS TO CANDIDATES:

- Write **your name**, and admission in the spaces provided above.
- This paper consists of **TWO** sections **A** and **B**
- Answer **ALL** the questions in section **A** in the spaces provided
- In section **B**, answer Question 6 (Compulsory) and either Question 7 or 8 in the spaces provided.

EXAMINER'S USE ONLY

SECTION	QUESTION	MAXIMUM SCORE	CANDIDATES SCORE
	1	8	
	2	8	
	3	8	
	4	8	
	5	8	
	6	20	
	7	20	
	8	20	
TOTAL SCORE		80	

1. The diagram below represents a nitrogen cycle.

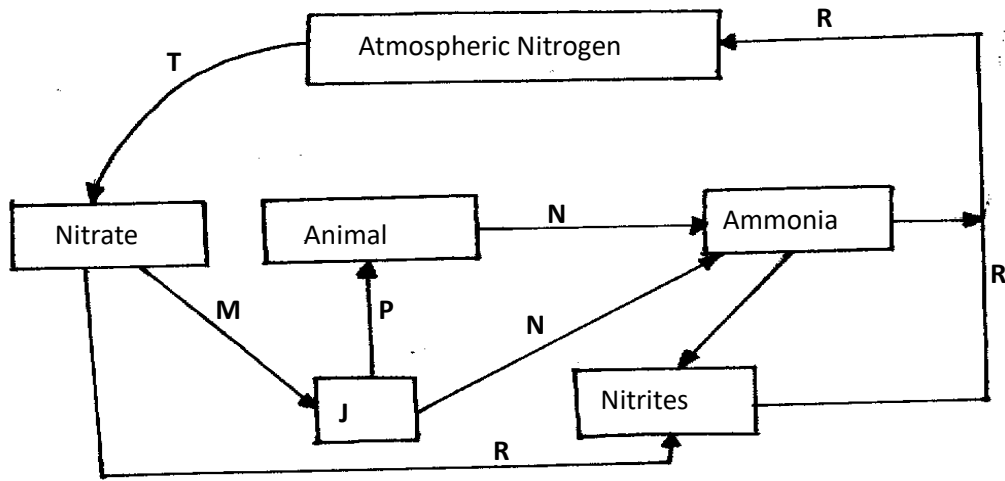

(a) Name the groups of organism represented by **J**. (1mrk)

.....

(b) Name the process represented by **R,P,M** and **N**. (4mrks)

R:

P:

M:

N:

(c) Name **one** process represented by **T**.

(1mrk)

.....

(d) (i) Name a structure in roots involved in process **M**. (1mrk)

.....

(ii) State **one** adaptation of the structure named in d (i) above to its function. (1mrk)

.....

2. The following diagram shows a cell at a certain stage of cell division.

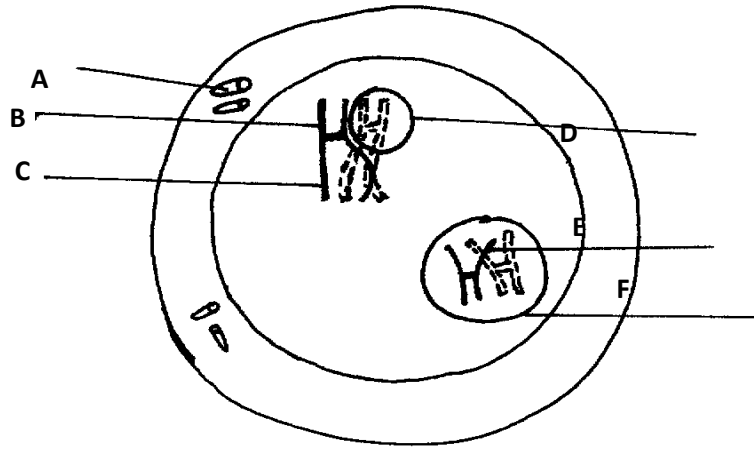

a) Name the type and stage of cell division. (1mrk)

Type.....

Stage.....

(b) (i) Give **one** reason for your answer in (a) above. (1mrk)

.....

(ii) What is the significance of the process shown in the diagram above in relation to the behavior of chromosomes? (1mrk)

.....

.....

(c) What is the general name of organs where the above process occurs? (1mk)

.....
.....

(d) Name the part labeled; (2mrks)

C

F

(e) State the significance of part labeled A in relation to the process shown above ?
(1mrk)

.....

(f) Name **one** cell in plants which is haploid (1mrk)

.....

3. In an experiment to analyze a 200cm^3 sample of air was treated with pyrogallic acid. This reduced its volume to 168cm^3 . Potassium hydroxide was then added and the volume of gas reduced further to 160cm^3

(a) What was the role of pyrogallic acid?
(1mrk)

.....
.....

(b) What was the role of potassium hydroxide?
(1mrk)

.....

(c) Calculate the percentage of oxygen and percentage of carbon (iv) oxide in the sample.(2mrks)

(d) Suggest the likely biological source of carbon (iv)oxide gas. (1mrk)

.....

(e) State the behavior of external intercostal muscles during exhalation. (1mk)

.....

.....

(f) Explain why smokers are more prone to respiratory tract infections than the non-smokers (2mks)

.....

.....

.....

.....

4. The diagram below represents **two** process underwent by a plant cell.

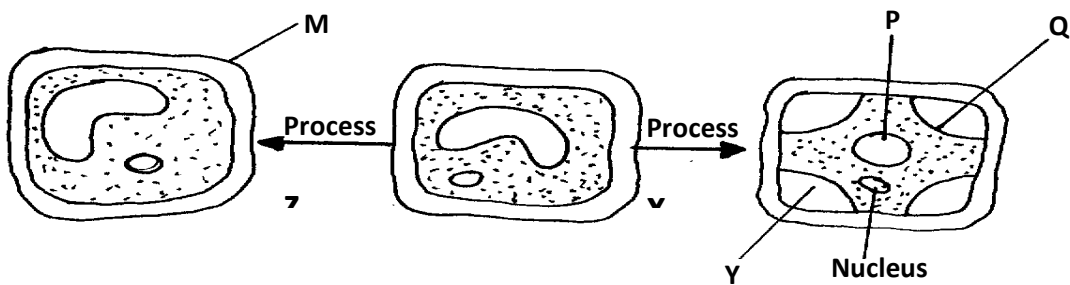

(a) Identify process **X**.....
(1mrk)

(b) Name the state of the cell after undergoing process;
(2mrks)

(i) **X**.....

(ii) **Z**

(c) Name the substance which is found in parts labelled; (2mrks)

(i) **P**.....

(ii) **Y**

(d) Name parts labelled **M** and **Q**. (2mrks)

M.....

Q..... (e) Name the cell organelle which is usually referred to as “cell’s kitchen”. (1mrk)

.....

5. (a) Name **two** substances transported in blood plasma.
(2mrks)

(i)

.....

(ii)

.....

(b) Wanjiru is blood group **A**.

(i) Name an antibody found in her blood plasma. (1mrk)

.....

(ii) Name an antigen found in her red blood cell.

(1mrk)

.....

(iii) Name the blood groups she can donate to;

(2mrks)

Blood groups-

(i)

.....

(ii)

.....

(c) What is meant by the term allergy?

(1mrk)

.....

.....

.....

.....

(d) Name **one** substance that can cause allergy.

(1mrk)

.....

SECTION B(40MARKS)

Answer questions 6 (Compulsory) and either question 7 or 8 in the spaces provided.

6. Two herbivorous mammal species were introduced into an ecosystem at the same time and in equal numbers. The graph below represents their populations during the first seven years. Study the graph and answer the questions that follow.

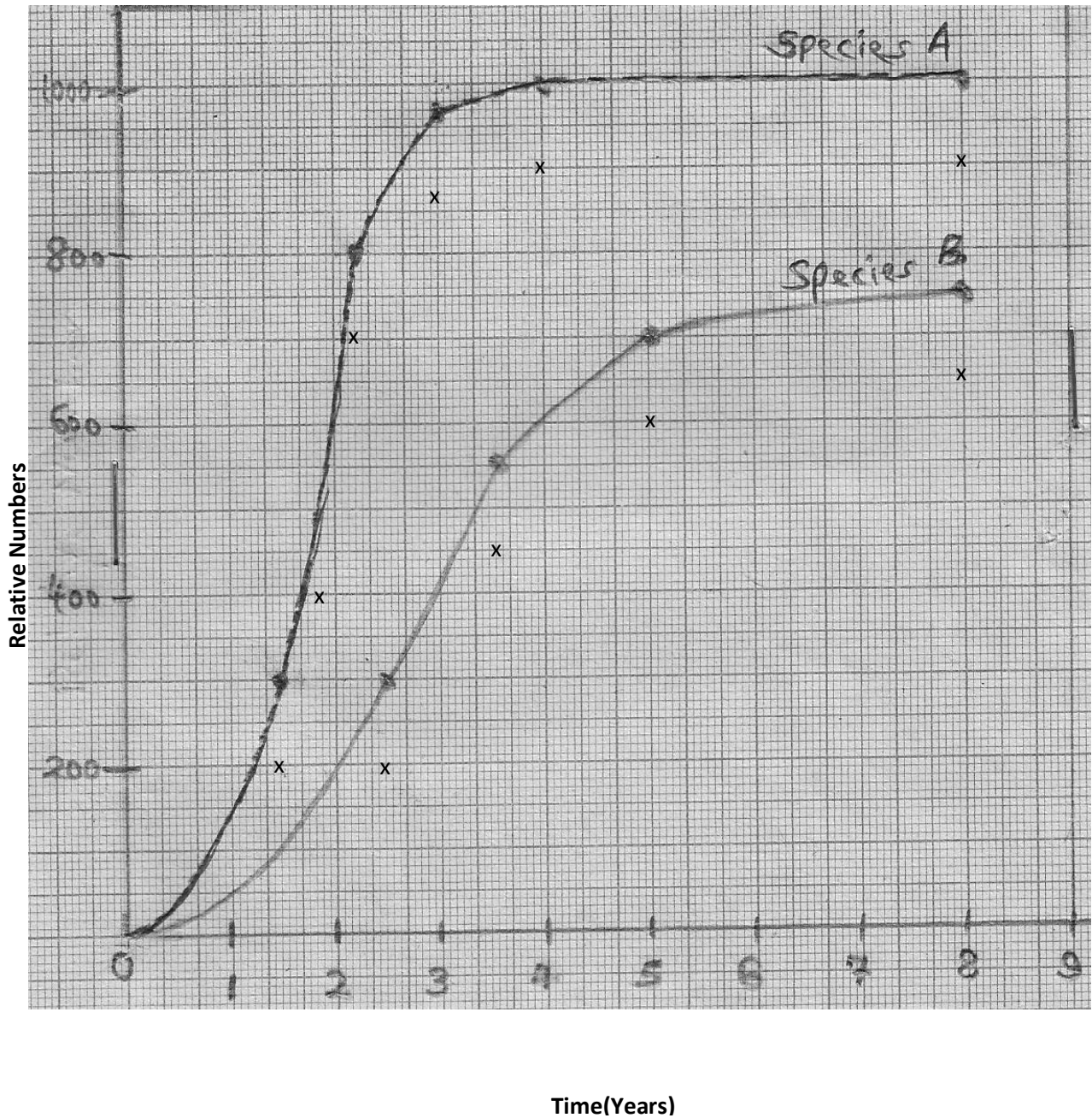

(a) (i) Which species has a better competitive ability?

(1mrk)

.....

(ii) Give a reason for your answer.

(1mrk)

.....

.....

.....

(b) Account for the shape of the curve for species A between;

(i) One year and three years.

(3mrks)

.....

.....

.....

(ii) 4 years and eight years.

(3mrks)

.....

.....

.....

(c) A natural predator of species A was introduced into the ecosystem. With a reason, state how the

population of each species would be affected?

(4mrks)

.....

.....

.....

.....

.....

(d) State **four** other biotic factors of the ecosystem which affects organisms distribution in their habitat other than the one illustrated in the above graph.

(4mrks)

.....

.....
.....
.....
.....
.....

(e) Name the instruments used to measure the following;

- (i) Light intensity.....
(1mrk)
- (ii) Light penetration in water.....
(1mrk)
- (iii) Speed of wind.....
(1mrk)
- (iv) Atmospheric pressure.....
(1mrk)

7. Describe how human male reproductive system is adapted to its functions(20 marks)

8. Describe how seeds and fruits are adapted to different modes of dispersal. (20marks)

.....
.....
.....
.....
.....
.....
.....
.....
.....

FORM 3 ENDTERM 2 EXAMS

CHEMISTRY

PAPER 1

TIME:2 HOURS

NAME..... ADM NO:.....

SIGN..... DATE;.....

233/1

CHEMISTRY

PAPER 1

FORM III

END TERM 2 EXAMS

Time: 2 hours

233/1
CHEMISTRY
FORM III

INSTRUCTIONS TO THE CANDIDATES:-

- v) Write your **name** and admission **number** on the spaces provided.
- vi) Answer **all** the questions in the spaces provided.
- vii) Mathematical tables and electronic calculators may be used
- viii) All working **MUST** be clearly shown where necessary.

Question	Maximum score	Candidate's score
1-30	80	

FOR MARKING SCHEMES CALL/WHATSAPP 0746 222 000

1. The diagram below shows Chromatograms for five different dyes.

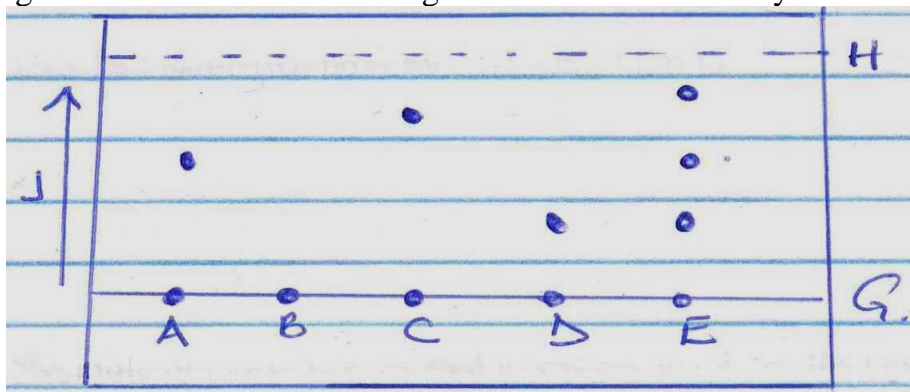

a) Name one condition required to separate the chromatograms present in a dye. (1 mk)

b) What is meant by the solvent front? (1 mk)

c) Which chromatograms are present in dye E. (1 mk)

d) Name two industrial applications of chromatography. (2 mks)

2. An element Y has the electronic configuration 2.8.5

a) Identify its period _____ (1mk)

b) Write a formula of the most stable anion formed when U ionizes. (1mk)

c) Explain the differences between the atomic radius of element Y and its ionic radius. (2mks)

3. a) What is meant by allotropy?

(1 mark)

.....

.

.....

.

b) The diagram below shows the structure of one of the allotropes of carbon

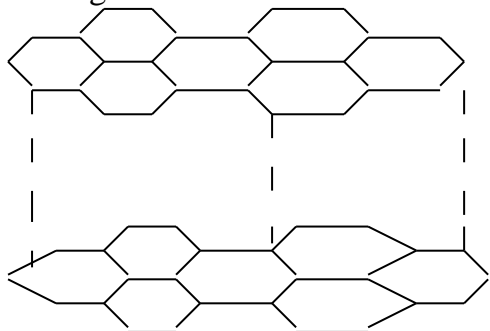

a. Identify the allotrope
mk)

(1/2

.....

b. State **one** property of the above allotrope and explain how it is related to its structure. (1½mk)

.....

.....

4. Study the flow chart below and answer the questions that follow.

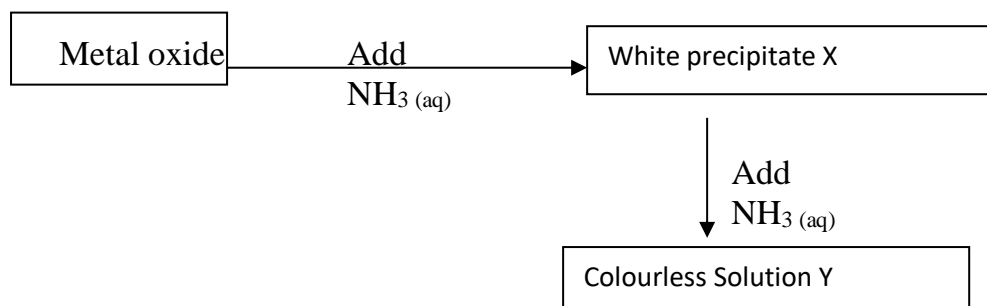

a) Identify the metal oxide.

(1mk)

b) Write an ionic equation leading to the formation of the white precipitate X. (1mk)

c) Give the formula of the ions responsible for the colourless solution Y. (1mk)

5. a) Apart from their location, state any two differences between a proton and an electron. **(2 mks)**

(b) Protons and neutrons are found in the nucleus of an atom. State two important roles played by neutrons in the nucleus of an atom. (2 mks)

6. Give equations to show the reactions that take place when;

d) Iron reacts with steam.

(1

mark)

(b) Name and give one industrial use of the gas produced in the reactions in (i) above. **(2mks)**

Name:

Use:

7. 20cm^3 of an unknown gas Q takes 12.6 seconds to pass through small orifice. 10cm^3 of oxygen gas takes 11.2 seconds to diffuse through the same orifice under the same conditions of temperature and pressure. Calculate the molecular mass of unknown gas Q (O=16).

(3mks)

8. A compound of carbon, hydrogen and oxygen contains 71.12g by mass of oxygen, 2.2g hydrogen and the rest is carbon. It has relative molecular mass of 90.

a) Determine the empirical formula of the compound.

(3mks)

b) Determine the molecular formula of the compound.

(2mks)

9. Study the information in the table and answer questions that follow:

Isotope	Relative abundance %
${}^{69}\text{R}_1$	61.3
${}^{71}\text{R}_2$	38.7

(a) Determine the number of neutrons of R_1

(1mk)

(b) Calculate the relative atomic mass of element **R**.

(2mks)

10. (a) Identify the type of bond formed in (i) and (ii).

(1mks)

FOR MARKING SCHEMES CALL/WHATSAPP 0746 222 000

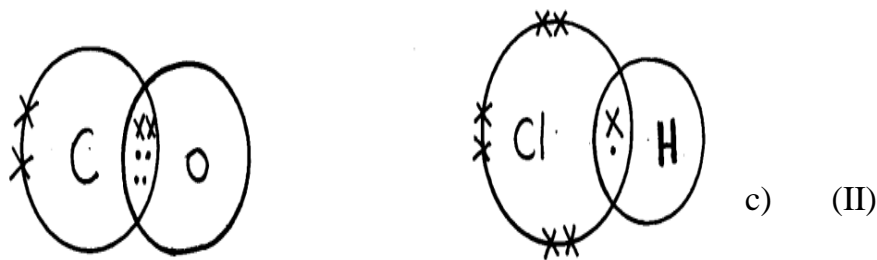

(I).....

(II).....

e) Use dot (.) and cross (x) diagram to draw the structure of Sulphur (IV) oxide. (2marks)

11. Complete the table below.

(3 mks)

Element	Latin Name	Symbol
_____	Plumbum	_____
Copper	_____	Cu
Potassium	_____	K
Tin		Sn

12. (a) State Gay Lussac's law.

(1mk)

b) What volume of oxygen will be required for complete combustion of 100cm³ of carbon (II) oxide. What is the volume of the product formed (All volumes at same temperature and pressure). (2mks)

13. If 25.0cm^3 of $0.1\text{ M H}_2\text{SO}_4$ solution neutralized a solution containing 1.06g of sodium carbonate in 250cm^3 of solution, calculate the molarity and volume of the sodium carbonate solution used.
(3mks)

14. (i) State Charles' law. (1mk)

(ii) The capacity of a balloon to hold a gas at 5°C is 1dm^3 before it bursts due to expansions show whether it will burst or not at 35°C at constant pressure.
(2mks)

15. What is the colour of the following?

Metal oxide	Colour when hot	Colour when cold
Zinc oxide	(i)	(ii)
Lead (II) oxide	(iii)	(iv)

(4mks)

16. Form two students from Anestar Premier High School reacted three elements as shown in the table below

Element	Reaction with Oxygen	Reaction with water
X	Formed acidic oxide	No reaction
Y	Formed basic oxide	Formed soluble hydroxide gave off hydrogen gas
Z	Formed acidic oxide	Dissolved to form an acidic solution

Which element (s) is likely to be:

(3mks)

i) Non-metal (s)

ii) Metal (s)

iii) Insoluble in water

17. State the function of the following parts of a Bunsen burner (3mks)

a) Air hole

b) Collar

c) Base

18. Study the flow chart below and answer the questions that follow

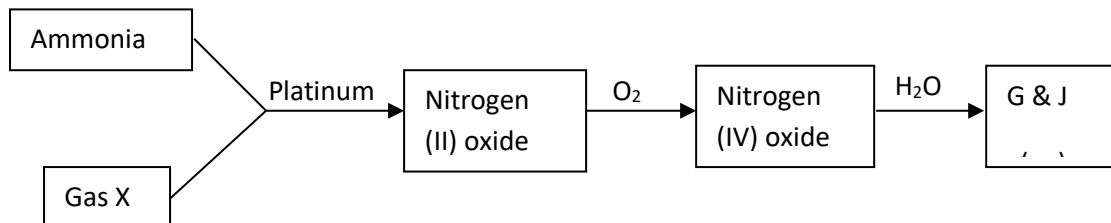

a) Identify gas X (1mk)

b) Write an equation for the reaction between ammonia and gas X (1mk)

c) Write an equation to show the formation of G and J (1mk)

19. The diagram below shows the effect of sunlight on chlorine water

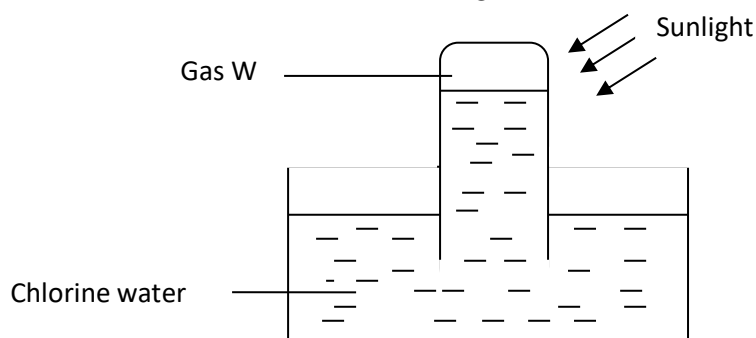

b) Identify gas W (1mk)

c) Write an equation to show the formation of gas W (1mk)

d) What compounds are present in chlorine water? (1mk)

e) Which compound is left in the beaker after complete formation of gas W? (1mk)

20. Study the table below and answer the questions that follow

Element	Atomic number	Atomic radius	Ionization energy
K	3	0.089	1800
V	11	0.136	1450
T	19	0.174	1150

d) Define the term '**ionization energy**' (1mk)

e) Explain the trend in the ionization energy from element K to T (2mks)

f) Compare the trend in the melting and boiling points of elements K and T. (2mks)

21. Explain using chemical means how you would differentiate between carbon (II) oxide and carbon (IV) oxide. (2mks)

22. The following diagram shows the effect of electric current on lead (II) Chloride.

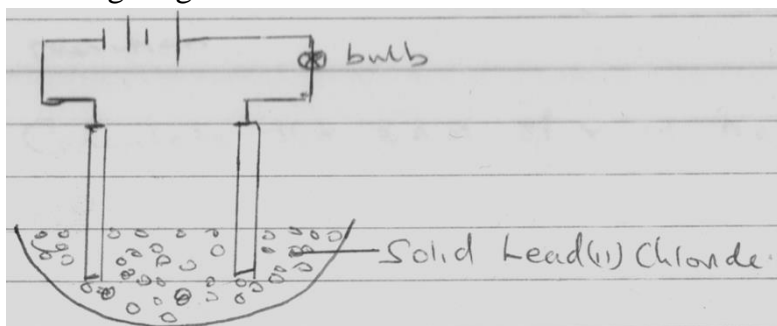

a) When the circuit was completed no current flowed. Explain why. (1mk)

b) When lead (II) Chloride was heated to about 300°C, it melted and there was light on the bulb. State and explain the observation made at the anode. (2mks)

23. The set-up below shows the products formed when solid lead (ii) nitrate is heated.

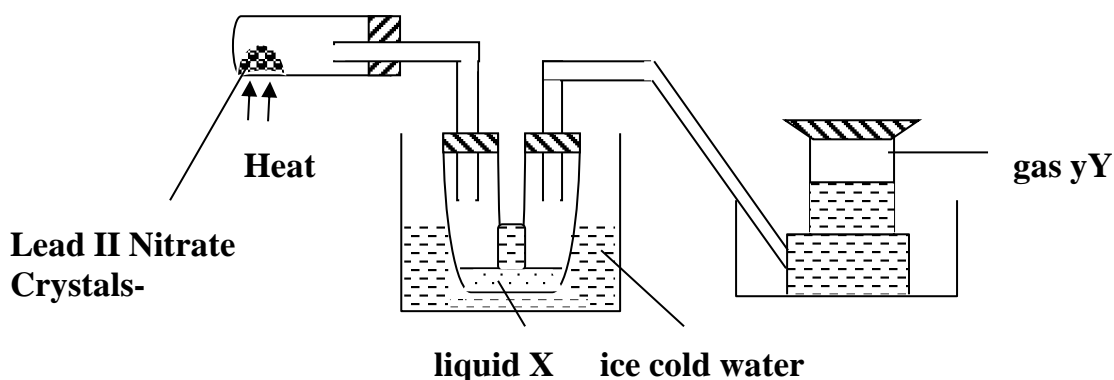

- a) Identify:
- (i) Liquid X (1 mark)
 - (ii) Gas Y..... (1 mark)

b) When lead (ii) Nitrate crystals are heated, they decrepitate and decompose, what is meant by the term decrepitating? (1 mark)

.....

24. Calculate the number of Al^{3+} ions released when 30cm³ of 0.1M of Aluminium Sulphate is dissolved in water. ($L = 6.024 \times 10^{23}$). (3mks)

FORM 3 ENDTERM 2 EXAMS

CHEMISTRY

PAPER 2

TIME:2 HOURS

NAME..... ADM NO:.....

SIGN..... DATE;.....

END OF TERM TWO EXAMINATIONS CHEMISTRY PAPER 2 (THEORY)

INSTRUCTIONS TO THE CANDIDATE

- Write your name, adm number and class in the space provided.
- Answer ALL the questions in the spaces provided.
- All working steps MUST be clearly shown, where necessary
- This paper consists of 8 pages
- Candidates should check the question paper to ascertain that all the pages have been clearly indicated and no question is missing.

1) Hydrogen can be prepared by reacting zinc with dilute hydrochloric acid.

a) Write an equation for the reaction.

(1mk)

.....

b) Name an appropriate drying agent for hydrogen gas.

(1mk)

.....

c) Explain why copper metal cannot be used to prepare hydrogen gas.

(2mks)

.....

.....

.....

d) Hydrogen burns in oxygen to form an oxide.

(i) Write an equation for the reaction.

(1mk)

.....

FOR MARKING SCHEMES CALL/WHATSAPP 0746 222 000

(ii) State **two** precautions that must be taken before the combustion begins and at the end of the combustion. **(2mks)**

.....
.....
.....

e) Give **two** uses of hydrogen gas. **(2mks)**

.....
.....
.....

f) When zinc is heated to redness in a current of steam, hydrogen gas is obtained. Write an equation for the reaction. **(1mk)**

.....

g) Element **Q** reacts with dilute acids but not with cold water. Element **R** does not react with dilute acids. Element **S** displaces element **P** from its oxide. **P** reacts with cold water.

Arrange

the four elements in order of their reactivity, starting with the most reactive. **(1mk)**

.....

2) (I) The number of protons, neutrons and electrons in atoms **A** to **F** are given in the table below
the letters do not represent the actual symbol of the elements:-

Atoms	Protons	Neutrons	Electrons
A	3	4	2
B	9	10	10
C	12	12	12
D	17	18	17
E	17	20	17
F	18	22	18

Choose from the table the letters that represent:

(i) An atom of a metal **(1mk)**

(ii) A neutral atom of a non-metal
(1mk)

- (iii) An atom of a noble gas (1mk)
- (iv) A pair of isotopes (1mk)
- (v) A cation (1mk)
- (vi) Anion (1mk)

(II) The grid below shows a part of the periodic table. The letters do not represent the actual symbols. Use it to answer the questions that follow:-

C							T
	K				U		
X	Y		M		Q	W	
J							Z

- iv) How do the atomic radius of element
 (i) **X** and **M** compare. Explain. (2mks)

.....

.....

- (ii) **U** and **Q**. Explain (2mks)

.....

.....

- v) Which letter represent the most reactive metal. Explain. (2mks)

.....

.....

.....

- vi) (i) Using crosses (**X**) to represent electrons, draw the atomic structure of element **Q** (1mk)

(ii) State the period and the group to which element **Q** belong (2mks)

Group

Period

(d) (i) The ionic configuration of element **G** is 2.8 G forms an ion of the type G^{-1} . Indicate on the grid, the position of element **G**. (1mk)

(ii) To which chemical family does element **G** belong? (1mk)

.....
(iii) State **one** use of element **U** (1mk)

.....
(iv) What is the nature of the compound formed between **K** and **U** (1mk)

.....
3) Study the set-up below and answer the questions that follow:

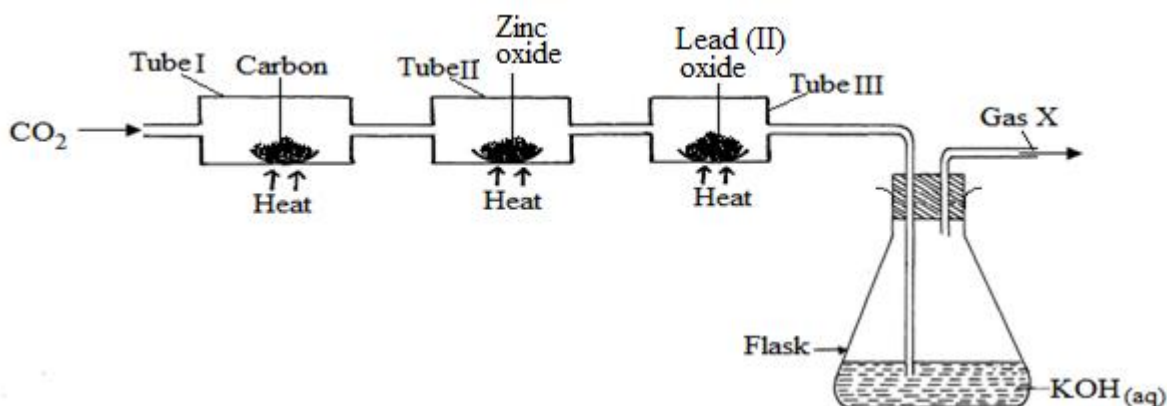

ii) (i) Name Gas **X** (1mk)

(ii) State the effect of releasing gas **X** to the environment (1mk)

.....
.....
.....
iii) Write down equations for the reactions taking place in;

(i) Tube **I** (1mk)

.....
(ii) Tube **II** (1mk)

(iii) Flask

(1mk)

iv) State the observation made in tube III

(1mk)

v) Write down an equation for the reaction which could be used to generate Carbon (IV) Oxide for the above set up

(1mk)

(e) Name the reagents used to generate gas X in the laboratory

(1mk)

(f) Complete the diagram above to show how excess gas X can be collected

(1mk)

4) The flow chart below illustrates two industrial processes, **Haber** process and the **Contact** process:

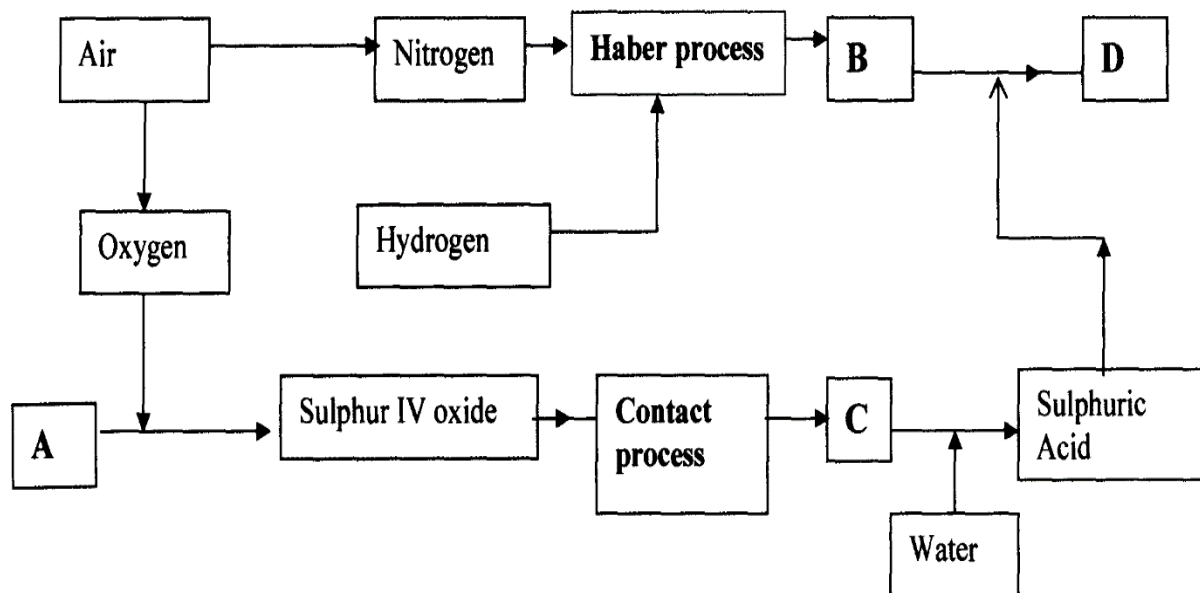

(a) (i) Give the name of the process by which air is separated into oxygen and nitrogen

(1mk)

d) Apart from oxygen and nitrogen gases produced from process (a)(i) name **one** other

gas produced

.....

(1mk)

(b) Name the substances represented by the letters **A, B, C** and **D** **(4mks)**

(i) A

(ii) B

(iii) C

(iv) D

(c) Name the catalysts used in:

(i) Haber Process (1mk)

(ii) Contact Process (1mk)

(d) Explain the role of the catalysts in both the Haber and the Contact processes (1mk)

.....
.....
.....

(e) Write a chemical equation for the formation of compound **B** (1mk)

.....
.....

(f) Calculate the percentage by mass of the nitrogen present in compound **D** (2 mks)

(g) Give **one** major use of compound **D** (1mk)

.....
.....

5) (a) Two reagents that can be used to prepare chlorine gas are manganese (IV) oxide and concentrated hydrochloric acid.

(i) Write an equation for the reaction (1mk)

.....

(ii) Give the formula of another reagent that can be reacted with concentrated hydrochloric acid to produce chlorine gas (1mk)

.....

(iii) Describe how the chlorine gas could be dried and collected in the laboratory(2 mks)

.....

.....

.....

(b) In an experiment, dry chlorine gas was reacted with aluminium as shown in the diagram below

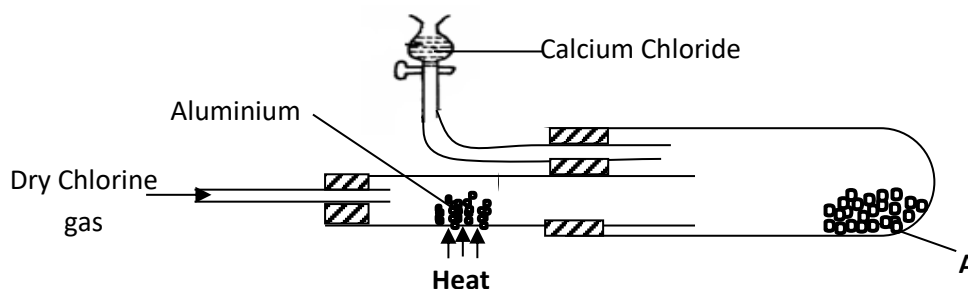

(i) Name substance A (1mk)

.....

(ii) Write an equation for the reaction that took place in the combustion tube (1mk)

.....

(iii) State the function of the calcium chloride in the set-up above (1mk)

.....

6) (a) Sulphur occurs naturally in two different forms called allotropes;

i) What are allotropes (1mk)

.....

.....

.....

ii) The two allotropes of sulphur are stable at different temperatures, as shown in the equations below.

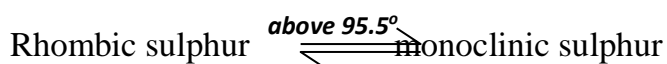

Give the name to the temperature 95.5°C

(1mk)

b) below is a flow diagram for the contact process for manufacture of sulphuric acid(VI)

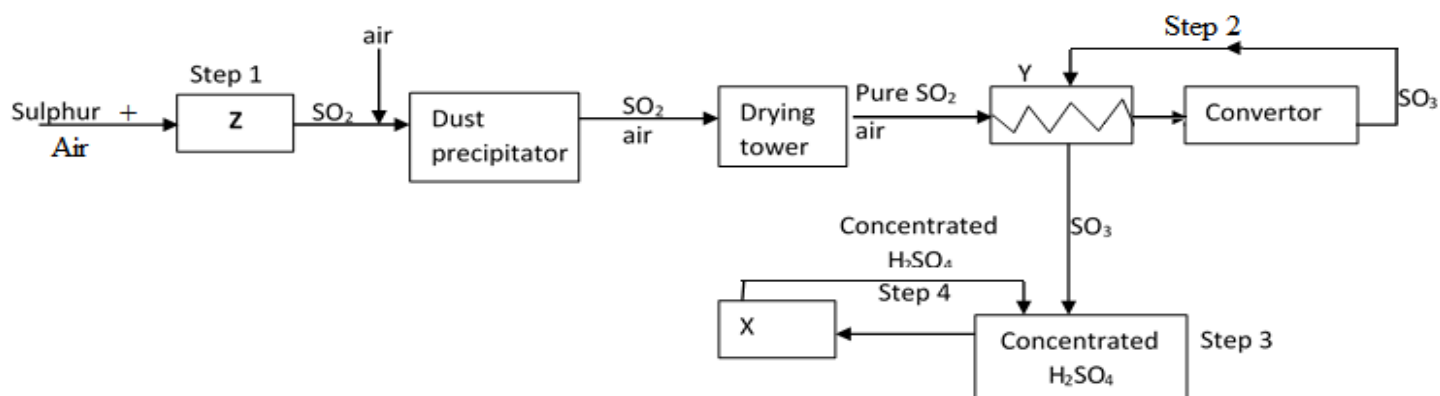

acid(VI)

iv) Give the name of the chambers labelled

(3mks)

Z

X

Y

ii) State the **three** conditions in the converter

(1mks)

iii) Explain why the gases are passed through:

29. The dust precipitator and drying tower

(1mk)

II. The chamber labeled Y

(1mk)

(iv) Write the balanced equations for the reactions in :

Step 2

(1mk)

Step 3

(1mk)

Step 4

(1mk)

7) The following flow chart shows the industrial manufacture of Nitric (V) acid.

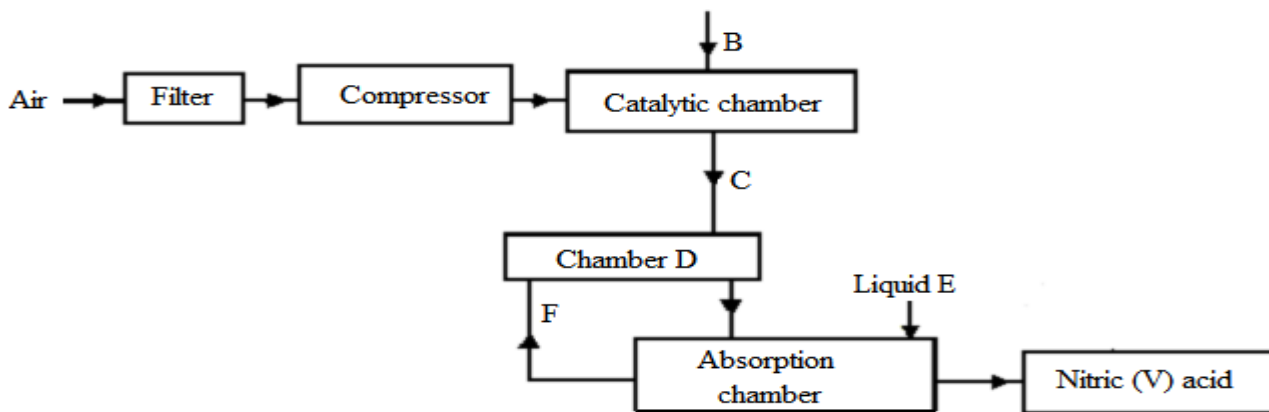

a) Identify substance **B**, **C**, **E** and **F**. (4mks)

- d) B
- e) C
- f) E
- g) F

b) Describe what happens in the catalytic chamber. (2mks)

.....

c) State what takes place in chamber **D**. (1mk)

.....

d) 60 – 65% nitric (V) acid is produced in the absorption chamber. Describe how the acid can be concentrated. (2mks)

.....

e) State why nitric (V) acid is stored in dark bottles. (1mk)

.....

f) Copper reacts with nitric (V) acid and not hydrochloric acid. Explain. (1mk)

.....

FORM 3 ENDTERM 2 EXAMS

PHYSICS

PAPER 1

TIME:2 HOURS

NAME..... ADM NO:.....

SIGN..... DATE;.....

INSTRUCTIONS:

- Write your name, Adm no., class, signature and date of examination in the spaces provided at the top of the page.
- Answer all the questions in the spaces provided after each question.
- All numerical answers should be expressed in decimal notations.
- You may use electronic calculators and tables.

8) The figure below shows a spherical ball placed between 2 wooden blocks and a meter rule.

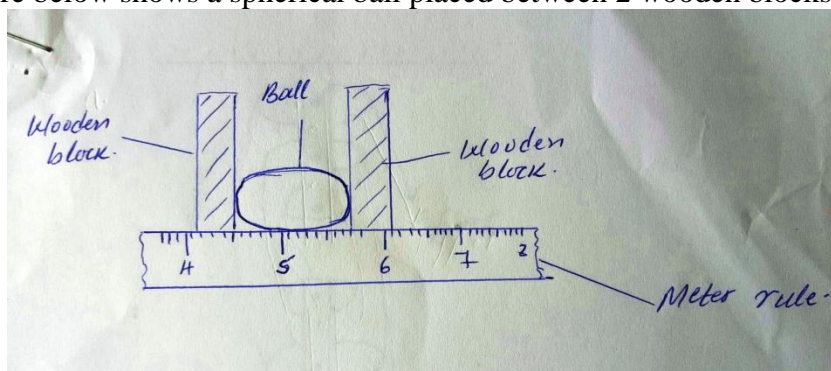

What is the volume of the ball?

(3 mks)

2. A solid weighs 16.5N on the surface of the moon. The force of gravity on the moon is 1.7N/kg. Determine the mass of the solid. (2 mks)

3. 30cm^3 of a liquid X was added to 70cm^3 of water and the resulting mixture had a volume slightly less than 100cm^3 , explain the observation. (2 mks)

4. Explain how heat loss by;

(i) Radiation is minimised in a vacuum flask. (1 mk)

(ii) Conduction is minimized in a vacuum flask. (1 mk)

5. The figure below shows part of a scale of vernier caliper. Given that the device has a zero error of -0.02 and has been used to measure the diameter of a ball.

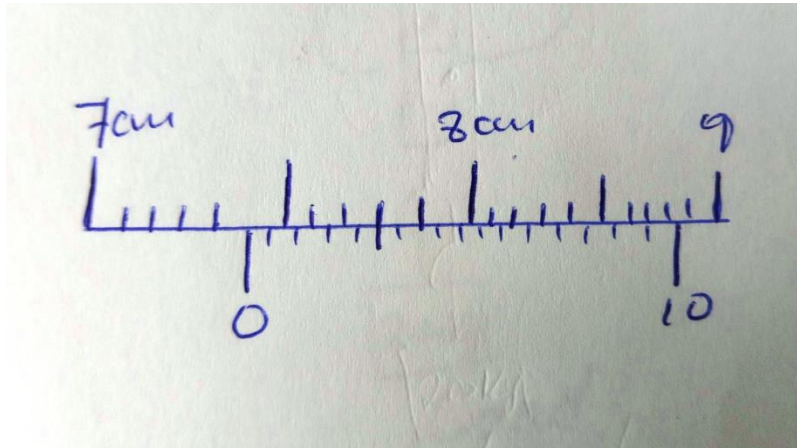

What is the radius of the ball?

(2 mks)

6. A pipe of radius 6mm is connected to another pipe of radius 9mm. If water flows in the wider pipe at 2m/s, what is the speed in the narrower pipe? (3 mks)

7. The springs below are identical and have negligible weight. The extension produced on the system of springs is 20cm.

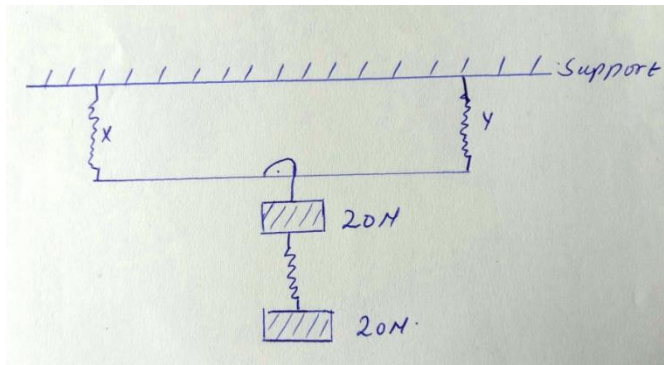

Determine the constant of each spring.

(4 mks)

8. An air bubble of volume 0.5cm^3 when released from the bottom of a lake rises to the surface of the lake.

(i) Explain why the bubble rises.

(2 mks)

(ii) Calculate the volume of the bubble at the surface of the lake given that the lake is 92.7m deep and the atmospheric pressure is equivalent to 10.3m of water pressure.

(4 mks)

(b) What assumption have you made in arriving at your answer?

(2 mks)

9. A fixed mass of gas at constant pressure has a volume of 600cm^3 at 0°C . At what temperature will its volume be 1099cm^3 ?

(4 mks)

10. (a) State three uses of magnets. (3 mks)

(b) Define the following terms as used in Physics:-

(i) Magnetic materials. (2 mks)

(ii) neutral point. (2 mks)

11. State three conditions for a body to be in equilibrium. (3 mks)

12. State four practical applications of friction. (4 mks)

13. Use simple sketches of a cone to illustrate the three states of equilibrium and name. (6 mks)

14. (a) Give a reason why water is not suitable as a barometric liquid. (3 mks)

(b) Explain the application of (a) above. (3 mks)

15. Use domain theory of magnetism to explain how a magnet may lose its magnetism on heating and hammering. (4 mks)

16. Explain the following observations:-

(i) A boy jumping from a high table tends to spread his legs. (1 mk)

(ii) Convex mirrors are not preferred for use as driving mirrors. (1 mk)

(iii) Why convex mirrors are used as driving mirrors and in supermarkets. (1 mk)

17. (a) State three practical applications of c.o.g. (3 mks)

(b) Name two factors that affect the c.o.g of a body giving a reason for each. (4 mks)

18. A car travelling at a speed of 72km^{-1} is uniformly retarded by application of brakes and comes to rest after 8 seconds. If the car with its occupants has a mass of 1250kg , calculate

FOR MARKING SCHEMES CALL/WHATSAPP 0746 222 000

a) breaking force. (2mks)

b) Work done by bringing it to rest (2mks)

19. A block and tackle system is used to lift a mass of 200kg. If this machine has a velocity ratio of 5 and an efficiency of 80%;

(a) Sketch a possible arrangement of the pulleys, showing how the rope is wound.(2 mks)

(b) Calculate the effort applied. (Take $g = 10\text{N/kg}$)

(2mks)

FORM 3 ENDTERM 2 EXAMS

PHYSICS

PAPER 2

TIME:2 HOURS

NAME..... ADM NO:.....

SIGN..... DATE;.....

SECTION A (25MKS)

(a) State two characteristics of image formed by plane mirrors. (2mks)

(b) State two factors that affects the speed of sound air. (2mks)

(c) What is a virtual image? (1mks)

(d) In the figure below, on the same diagram sketch the path of the ray after striking mirror AB. (1mk)

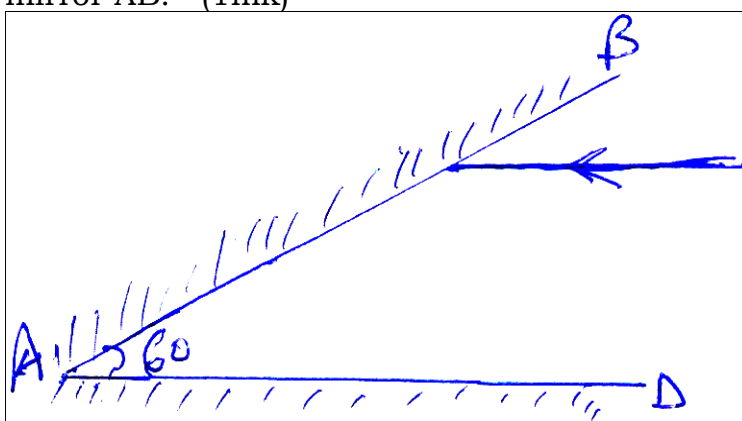

(e) An object is 25m tall is at a point 8m from the pin hole camera. If the image is 8.6m from the pin hole. Calculate the size of the image. (3mks)

(f) A curve at the bottom of a jar glycerin appears to be 13,2cm below the surface glycerin. Calculate the height of the Column of glycerin in the jar. (refractive index of glycerin is 1.47.

(g) State the law of electrostatics. (1mk)

(h) The figure below shows resistor network.

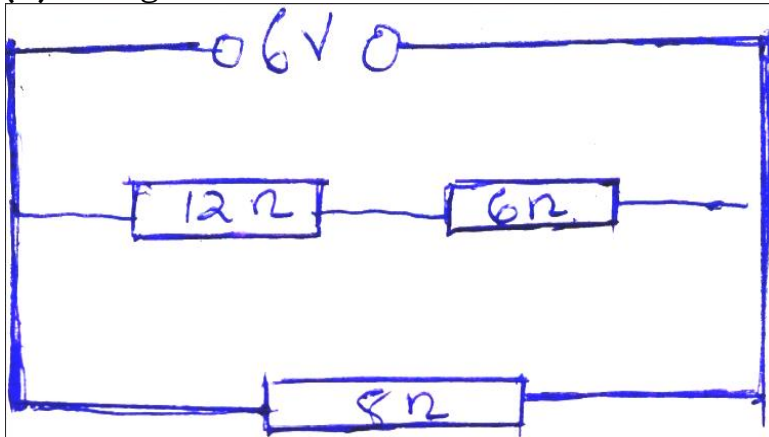

From the figure determine
f) Total resistance. (3mks)

g) Total current. (3mks)

(i) Distinguish between primary and secondary cells. (1mk)

(j) Give two uses of a gold leaf electroscope. (2mks)

(k) Two mirrors are inclined at an angle 60° determine the number of images formed. (3mks)

SECTION B (55MKS)

(l) The figure below shows a transparent water tank containing water. An electric lamp surrounded by a shield with a narrow slit is fixed at corner A of the tank. A light ray from the slit shines on the water surface BC at an angle of 48° as shown. Refractive index of water is $\frac{4}{3}$

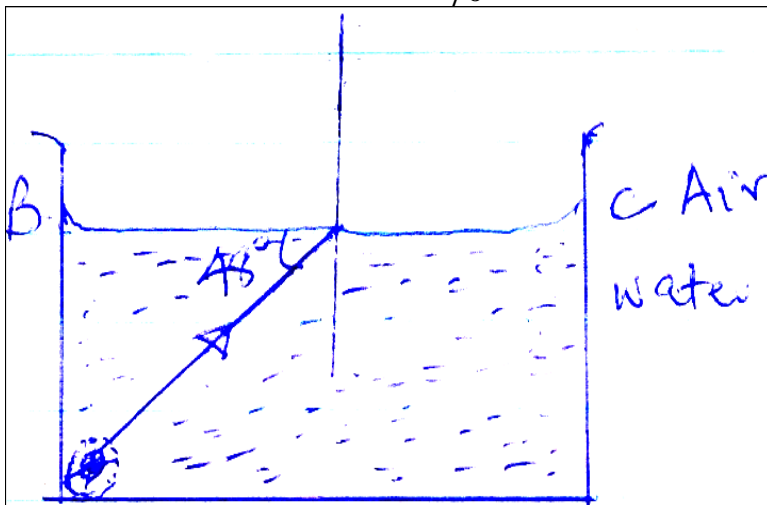

vii) Determine the angle of refraction for the ray shown. (3mks)

viii) Complete the ray diagram to show refracted ray (1mk)

ix) Determine the angle of incidence for which the angle of refraction is 90° (3mks)

x) Calculate the speed of light in water given that the speed in air is $3.0 \times 10^8 \text{ m/s}$

(m) a) Draw magnetic field pattern between the following poles. (2mks)

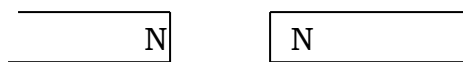

b) Using domain theory, explain why it is not possible to magnetize a magnetic material beyond a certain limit. (3mks)

h) The figure below shows an electromagnet connected to a battery.

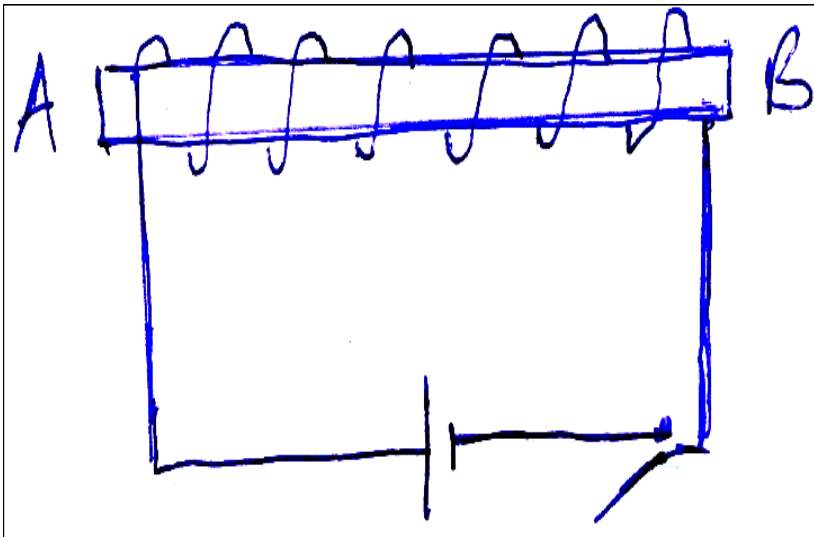

i) On the same diagram indicate the direction of the flow of current when the switch is closed. (1mk)

ii) State polarities A and B. (2mks)

iii) State three ways of increasing the strength of the electromagnet. (3mks)

iv) State two uses of electromagnets (2mks)

(n) a) Define the following terms

ix) Amplitude (1mk)

x) Frequency (1mk)

b) state one difference between electromagnetic and mechanical waves give one example in each. (4mks)

i) The wave shown in the figure below has a velocity of 200m/s.

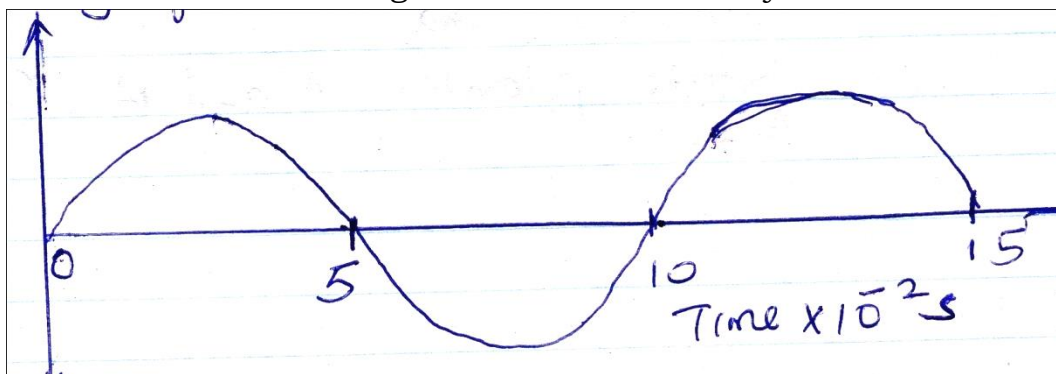

Determine

f) The period of the wave. (1mk)

g) The frequency of the wave. (3mks)

h) The wavelength of the wave, (3mks)

(o) a) The figure below shows circular waves approaching a concave reflector. Show the reflected waves. (2mks)



b) In the figure below water waves of one incident on an aperture which is greater than the wavelength of the waves. Show the pattern of the waves beyond the aperture. (2mks)

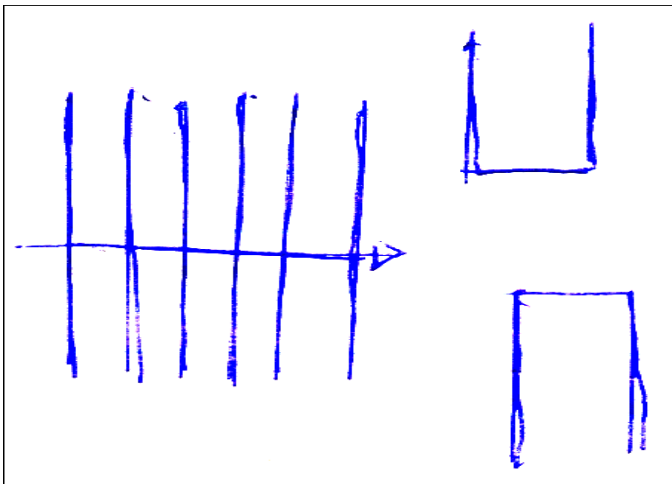

j) The figure below shows the set up to demonstrate interference of sound.

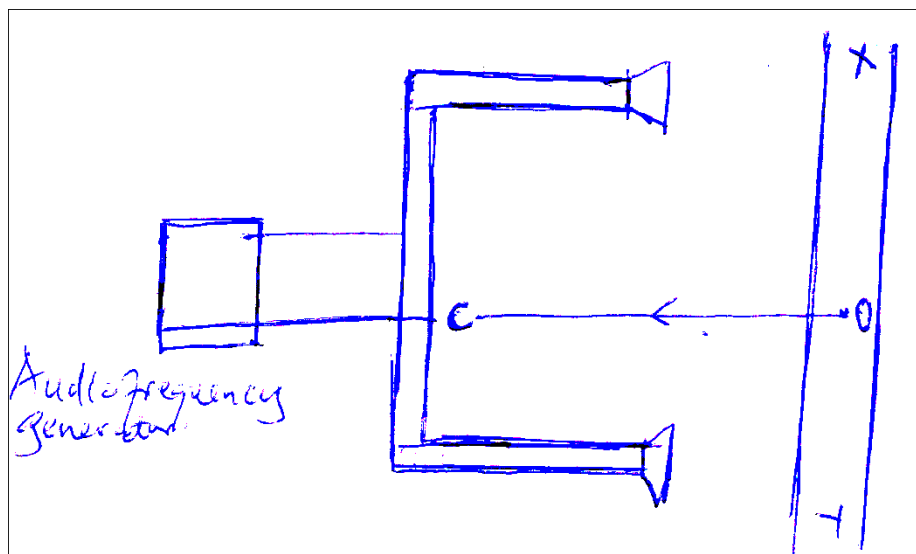

30. An observer moves along XY state and explain what the observer will hear. (3mks)

31. State and explain what now the observers will hear if he moves along line OC (2mks)

(p) a) State ohms law. (1mk)

b) Differentiate between potential difference (pd) and electromotive force (Emf)
(2mks)

c) A cell drives a current of 2.0A through 0.6 resistor. When the same cell is connected to 0.952 resistor the current that flows is 1.5A. find.

i) The internal resistance of the cell. (3mks)

ii) The electromotive force (Emf) of the cell. (3mks)

k) State two factors that affect the resistance of metallic conductor. (2mks)

FORM 3 ENDTERM 2 EXAMS

MATHEMATICS

PAPER 1

TIME:2 ½ HOURS

NAME..... ADM NO:.....

SIGN..... DATE;.....

SECTION I(50 marks)

Answer all the questions in this section in the spaces provided.

1. Evaluate: (3mks)

$$\frac{1}{2} \left(\frac{3}{5} + \frac{1}{4} \left(\frac{7}{3} - \frac{3}{7} \right) \right) \text{ of } 1\frac{1}{2} \div 5$$

2. A triangle has vertices A(2,5), B(1,-2) and C(-5,1). Determine;

a) The equation of line BC. (2mks)

b) The equation of perpendicular line from A to BC. (2mks)

3. The shaded region in the figure below shows an area swept out on a flat windscreen by a wiper. Calculate the area of the region. Take $\pi = 3.142$. (3mks)

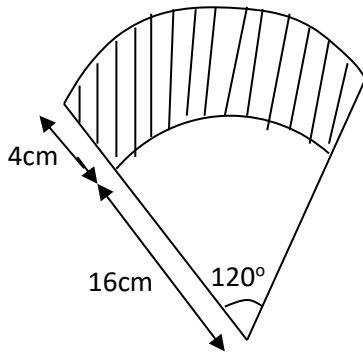

4. A piece of metal has a volume of 20cm^3 and a mass of 300g. Calculate the density of the metal in kg/m^3 . (3mks)

5. List the integral values of x which satisfy the inequalities below. (3mks)

$$2x + 21 > 15 - 2x \geq x + 6$$

6. Janet is a saleslady earning a basic salary of Kshs. 20,000 per month and a commission of 8% for the sales in excess of Kshs. 100,000. If in January 2010 she earned a total of Kshs. 48,000 in salaries and commissions. Determine the amount of sales. She made in that month.

(3mks)

7. The interior angle of a regular polygon is 108° larger than the exterior angle. Find the number of sides of the polygon. (3mks)

8. Given that $\cos A = \frac{5}{13}$ and angle A is acute. Find the value of $2\tan A + 3\sin A$ without calculators.

(3mks)

9. Without using a calculator evaluate: (2mks)

$$\frac{-9 + (-7) \times (-8) - (-5)}{-2 + (-6) \div 3 \times 6}$$

10. Solve for x in the equation below. (3mks)

$$\frac{6x - 4}{3} - \frac{2x - 1}{2} = \frac{6 - 5x}{6}$$

11. Calculate the area of the trapezium show below. (3mks)

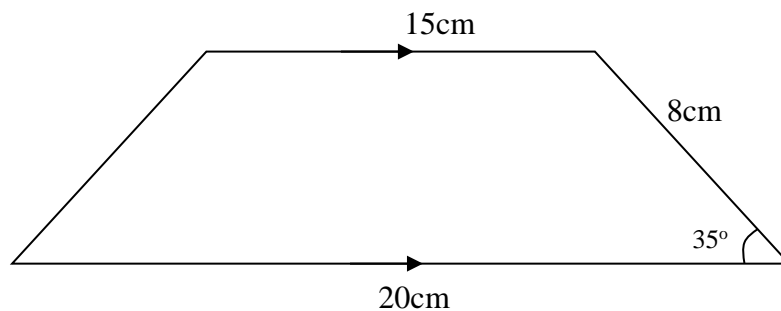

12. Solve the simultaneous equation. (4mks)

$$\begin{aligned}x^2 + y^2 &= 26 \\x + y &= 4\end{aligned}$$

13. Express 72 and 125 as products of their prime factors. (2mks)

14. A service vehicle left town P for town Q at 1000hrs had a puncture after travelling for 4 hrs 20 mins. Fixing a new tyre took 33 minutes. The vehicle then travelled for 1 hr 20mins to reach town Q. At what time did it arrive in 12 hour clock system?

(3mks)

15. A tourist visited Kenya with 2500 US dollars and changed the US dollars into Kenya shillings at a local bank in Kenya when the exchange rates at the time were as follows:

	<i>Buying</i>	<i>Selling</i>
1 US dollar	shs.78.45	shs. 78.55
1 Sterling Pound	shs.120.25	shs. 120.45

a) How much did he get in Kenya shillings?

(2mks)

b) While in Kenya he used shs. 80,000 and after his stay he converted the remaining amount into Sterling pounds. Calculate to 2 decimal places the Sterling pounds that he got.

(2mks)

16. Use logarithms tables to evaluate:

(4mks)

$$\sqrt[3]{\frac{497 \times 9.84}{5.24 \times 7.65}}$$

SECTION II (50 marks)

Answer any five questions in this section in the spaces provided.

17. A motorist left Embu for Nairobi a distance of 240km at 8:00 a.m. and travelled at average speed of 90km/hr. Another motorist left Nairobi for Embu at 8:30a.m and travelled at 100km/hr. Find;

a) The time they met. (3mks)

b) How far they met from Nairobi. (3mks)

c) The time of the day each motorist arrived at his destination. (4mks)

18. A farmer has a rectangular farm which measures 100m by 80m. The farmer intends to fence the plot using post at intervals of 4m apart leaving a gate of 4m. Also he will use four strands of barbed wire. Each post cost shs. 125 and wire is sold at rolls of 60m costing 1,500/= . Calculate;
- a) The number of post he will use. (2mks)
- b) The total length of the barbed wire. (2mks)
- c) The total cost of fencing the farm if the cost of the gate is 8,000/= and labour is shs. 1,500. (3mks)
- d) The farmer wishes to subdivide further the farm into square plot. Find the maximum area of each plot. (2mks)
19. The parents of a certain mixed school decided to buy a school van worth Kshs 900,000. Each student was to contribute the same amount of money. 50 students were transferred from the school as a result each of the remaining students had to pay kshs.600 more.
- a) Find the original number of the students in the school. (5mks)

b) Find the percentage change in contributions per student. (3mks)

c) If the ratio of boys to girls in the school was 11:7, find the amount of money contributed by boys alone. ((2mks)

20. The figure below shows two circles of radii 8cm and 6cm with centres O_1 and O_2 respectively. The circles intersect at points A and B. The lines O_1O_2 and AB are perpendicular to each other. If the common chord is 9cm; (Take $\pi=3.142$.

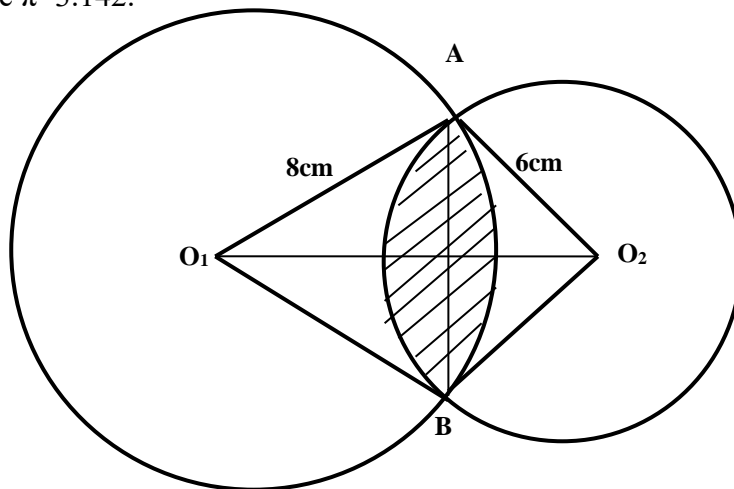

Calculate to 4.s.f.

a) Angle AO_1B (2mks)

b) Angle AO_2B (2mks)

c) Area of the shaded region.

(6mks)

21. A village water tank is in the form of a frustum of a cone of height 3.2m. The top and bottom radii of 18m and 24m respectively as shown below.

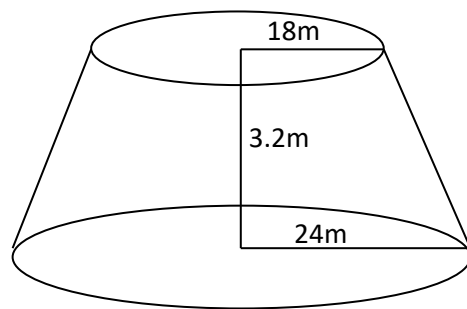

a. Calculate;

i. The surface area of the tank excluding the bottom.

(4mks)

ii. The capacity of the tank in litres.

(3mks)

b. 15 families each having 15 members use the water tank and each person uses 65 litres daily. How long will it take for the full tank to be emptied?

(3mks)

22. Measurements of a maize field using baseline XY were recorded as shown below in metres

	Y	
	240	
To R 160	190	
	180	75 To Q
	150	50 To P
To S 100	120	
	100	100 To N
To T 30	50	
	20	20 To M
	X	

a) Show the map of the maize field by scale drawing. Take 1cm rep 20m.

(4mks)

b) Find the area of the field in hectares. (4mks)

c) If the cost of one hectare is Kshs. 65,000, find the total cost of the maize field. (2mks)

23. Using a ruler and pair of compass only construct the following.

a) Triangle XYZ where XY is 6cm and angle XYZ is 135° and YZ=7cm. Measure XZ. (3mks)

b) Drop a perpendicular from Z to meet line XY at K. measure YK. (3mks)

c) Bisect line XY and let the bisector meet line XZ at Q. (2mks)

d) Join Q to Y and measure angle XQY. (2mks)

24. Complete the table for the function.

a) $y=1 - 2x - 3x^2$ in the range $-3 \leq x \leq 3$ (2mks)

x	-3	-2	-1	0	1	2	3
$-3x^2$	-27		-3	0		-12	

FOR MARKING SCHEMES CALL/WHATSAPP 0746 222 000

-2x				0			-6
1	1	1	1	1	1	1	1
y	-20			1		-15	

b) Use the table above to draw a graph of $y=1 - 2x - 3x^2$ on the graph provided. (4mks)

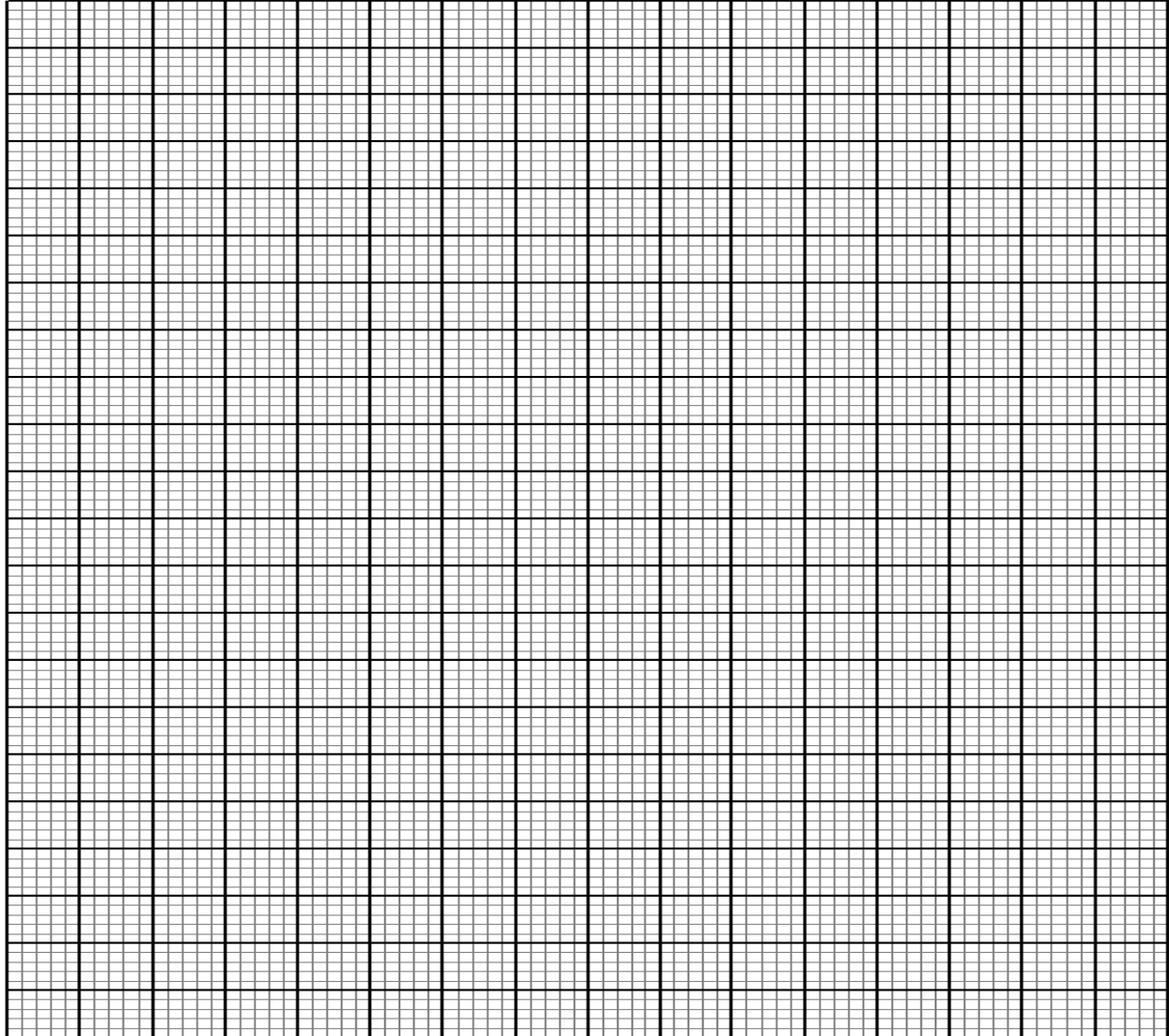

c) Use the graph in (b) above to solve;

i. $1 - 2x - 3x^2 = 0$ (2mks)

ii. $2 - 5x - 3x^2 = 0$ (2mks)

FORM 3 ENDTERM 2 EXAMS

MATHEMATICS

PAPER 2

TIME: 2 ½ HOURS

NAME..... ADM NO:.....

SIGN..... DATE;.....

INSTRUCTIONS TO CANDIDATES

1. Write your name and admission number in the spaces provided
2. Answer all questions in section I and any five questions in Section II
3. All Workings and answers must be clearly written in the spaces provided.
4. Marks may be awarded for correct working even if the answer is wrong.
5. Non programmable silent electronics and KNEC Mathematical tables may be use, except where otherwise.

FOR EXAMINERS USE ONLY

SECTION I

Question	1	2	3	4	5	6	7	8	9	10	11	12	13	14	15	16	TOTAL
Marks																	

SECTION II

QUESTION	17	18	19	20	21	22	23	24	TOTAL
MARKS									

This paper consists of 16 printed pages. Candidates should check the question paper to ascertain that all pages are printed as indicated and that no questions are missing

GRAND TOTAL

--

SECTION I (50 MARKS)

ANSWER ALL QUESTIONS IN THIS SECTION

1. Evaluate using logarithms.

[4 Marks]

$$\frac{\sqrt[3]{0.04689}}{51.64 \times 0.793}$$

2. A rectangular card measures 5.3cm by 2.5cm. Find

a) The absolute Error in the area of the card. [2Marks]

b) The Percentage Error in the Area of the card [2Marks]

3. The length of a room is 4m longer than its width. Find the length of the room if its area is 32m². [3 Marks]

4. If 20 Men can lay 36m of a pipe in 8 hours. How long would 25 Men take to lay the next 54m of the pipe?
[2 Marks]

5. Expand $(2 + x)^5$ in ascending powers of x up to the term in x^3 . Hence, approximate the value of $(2.03)^5$ to 4s.f.

(4marks)

6. Simplify by rationalizing the denominator;

$$\frac{3}{2\sqrt{3} - \sqrt{2}}$$

[2 Marks]

7. A scientific calculator is marked at sh. 1560. Under hire purchase it is available for a downpayment of sh. 200 and six monthly instalments of sh. 250 each. Calculate;

- a. The Hire purchase price.

[2 Marks]

- b. The extra amount paid out over the cash price.

[1 Mark]

8. Solve the equation;

$$\log(2x - 10) - 2\log 8 = 2 + \log(9 - 2x)$$

[3 Marks]

9. The Equation of a circle is given by $x^2 + y^2 - 6x + 4y - 3 = 0$. Determine the center and the radius of the circle. [3 Marks]

10. Make x the subject of the formula in the equation.

(3mrks)

$$y = \frac{bx}{\sqrt{ax^2 + b}}$$

$$\sqrt{ax^2 + b}$$

11. In the figure below, BT is a tangent to the circle to the circle at B. AXCT and BXD are straight lines. AX=6cm, CT=8cm, BX=4.8cm and XD=5cm.

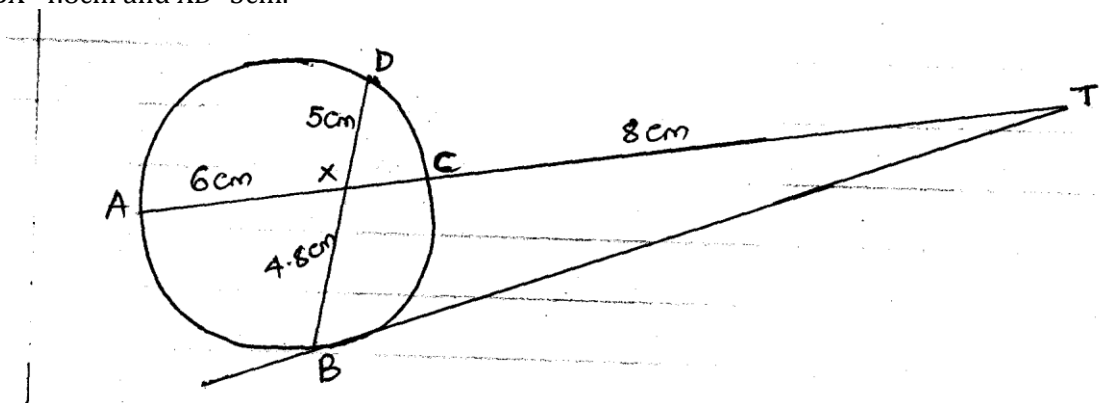

Find the length of;

a. XC

[2 Marks]

b. BT

[2 Marks]

12. Find the value of x if the matrix $\begin{pmatrix} x & 1 \\ 4 & x-3 \end{pmatrix}$ is a singular matrix. [3 Marks]

13. The first term of an arithmetic sequence is -7 and the common difference is 4.
a. List the first 6 terms of the sequence [2 Marks]

b. Determine the sum of the first 30 terms of the sequence [2 Marks]

14. The coordinates of points A and B are (2,5) and (8, -7) respectively. Find the
a) Coordinates of M Which Divides AB in the Ratio 1:2 [2 Marks]

b) Magnitude of AB [2 Marks]

15. Tap A Fills a tank in 6 hours, tap B fills it in 8 hours and tap C empties it in 10 hours. Starting with an empty tank and all the three taps are opened at the same time, how long will it take to fill the tank. [3 Marks]

16. Grade X of Tobacco Costs Sh.81.50 per Kg and grade Y cost sh 109 per Kilogram. In what ratio must the two grades be mixed in order to make a profit of 20% when the mixture sells at sh. 112.80 per kg. [3 Marks]

SECTION II: ANSWER ANY 5 QUESTIONS IN THIS SECTION(50MARKS)

17. The figure below shows triangle OAB in which M divides OA in the ratio 2: 3 and N divides OB .in the ratio 4:1 AN and BM intersect at X.

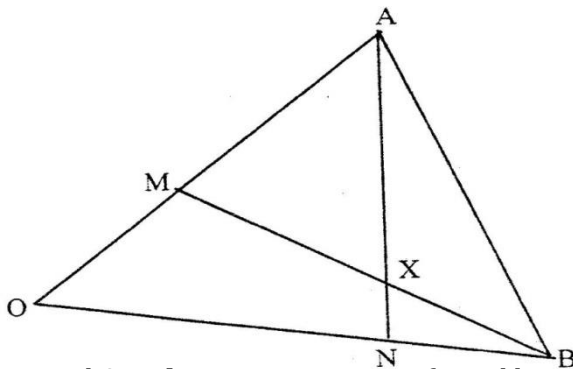

(a) Given that $OA = \mathbf{a}$ and $OB = \mathbf{b}$, express in terms of \mathbf{a} and \mathbf{b} : (4mks)

(i) \mathbf{AN}

(ii) \mathbf{BM}

(b) If $\mathbf{AX} = s\mathbf{AN}$ and $\mathbf{BX} = t\mathbf{BM}$, where s and t are constants, write two expressions for \mathbf{OX} in terms of \mathbf{a} , \mathbf{b} , s and t . Find the value of s and t . Hence write \mathbf{OX} in terms of \mathbf{a} and \mathbf{b} (6mks)

18. Kamau, Njoroge and Kariuki are practicing archery. The probability for Kamau hitting the target is $\frac{2}{5}$, that of Njoroge hitting the target is $\frac{1}{4}$ and that of Kariuki hitting the target is $\frac{3}{7}$. Find the probability that in one attempt;

a) Only one hits the target (2mks)

b) All three hit the target (2mks)

c) None of them hits the target (2mks)

d) Two hit the target (2mks)

e) At least one hits the target (2mks)

19. A matrix T is given by $T = \begin{pmatrix} 4 & 5 \\ 6 & 4 \end{pmatrix}$. Find T^{-1} [2 Marks]

b) Wanjiku bought 20 bags of maize and 25 bags of beans at a total cost of sh. 77,000. If she had bought 30 bags of maize and 20 bags of beans, she would have spent sh. 7,000 more.

i. Form a matrix equation from this information. [1 Mark]

ii. Determine the cost of a bag of maize and a bag of beans. [3 Marks]

c) She sold all the maize and beans at a profit of 10% on a bag of maize and 12 ½ % on a bag of beans. Calculate the total percentage profit. [4 Marks]

20. At the beginning of the year 2000, Kanyora bought two houses, one in Thika and the other in Nakuru each at 1,240,000. The value of the house in Thika appreciated at a rate of 12% p.a.

a. Calculate the value of the house in Thika after 9 years to the nearest shilling.

[2 Marks]

b. After n years, the value of the house in Thika was 2,741,245 while the value of the house in Nakuru was 2,917,231.

i. Find n

[4 Marks]

ii. Find the annual rate of appreciation of the house in Nakuru.

[4 Marks]

21. The table below shows income tax rates.

Taxable Income In K£ Per Month	Rate in shs. per k£
1 - 325	2
326 - 650	3
651 - 975	4
976 - 1300	5
1301 - 1625	6
Over 1626	7

Mr. Wafula earns a basic salary of 30,500. He has a house allowance of sh. 6,000 per month, medical allowance of sh. 4,000 per month and transport allowance of sh. 3,000 per month. He claims a tax relief of sh. 1,056 per month.

a. Calculate

i. Wafula's taxable income in k£ per month.

[2 Marks]

ii. Gross tax.

[3 Marks]

iii. Net Tax

[2 Marks]

b. His net income per month has the following deductions

Health insurance fund – sh. 150

Loan interest – sh. 200

Service charge – sh. 200

Sacco loan – sh. 2,500

Calculate his net income per month.

[3 Marks]

22.

a) P varies jointly as Q and the square of R. P = 18 when Q = 9 and R = 15. Find R when P=32 and Q=81.
[5 Marks]

b) A varies Directly as B and inversely as the square root of C. Find the percentage change in A When B is decreased by 10% and C increased by 21%.
[5 Marks]

23.

a) The first term of an arithmetic progression is 2. The sum of the first 8 terms of the AP is 240.

i. Find the common difference of the AP.

[2 Marks]

ii. Given that the sum of the first n terms of the AP is 1,560. Find n [2 Marks]

b) The 3rd, 5th and 8th terms of another AP from the first three terms of a G.P. If the common difference of the AP is 3. Find.

i. The first term of G. P

[4 Marks]

ii. The sum of the first 9 terms of the G.P to 4 s.f.

[2 Marks]

24.

a) Complete the table below for the function $Y=2x^2 + 4x - 3$

[2 Marks]

x	-4	-3	-2	-1	0	1	2
$2x^2$	32			1	0		8
$4x$	-8	-12	-8			4	8
-3	-3	-3	-3	-3	-3	-3	-3
y	21		-3				

b) On the grid provided, draw the graph of the function $y = 2x^2 + 4x - 3$ for $-4 \leq x \leq 2$ [3 Marks]

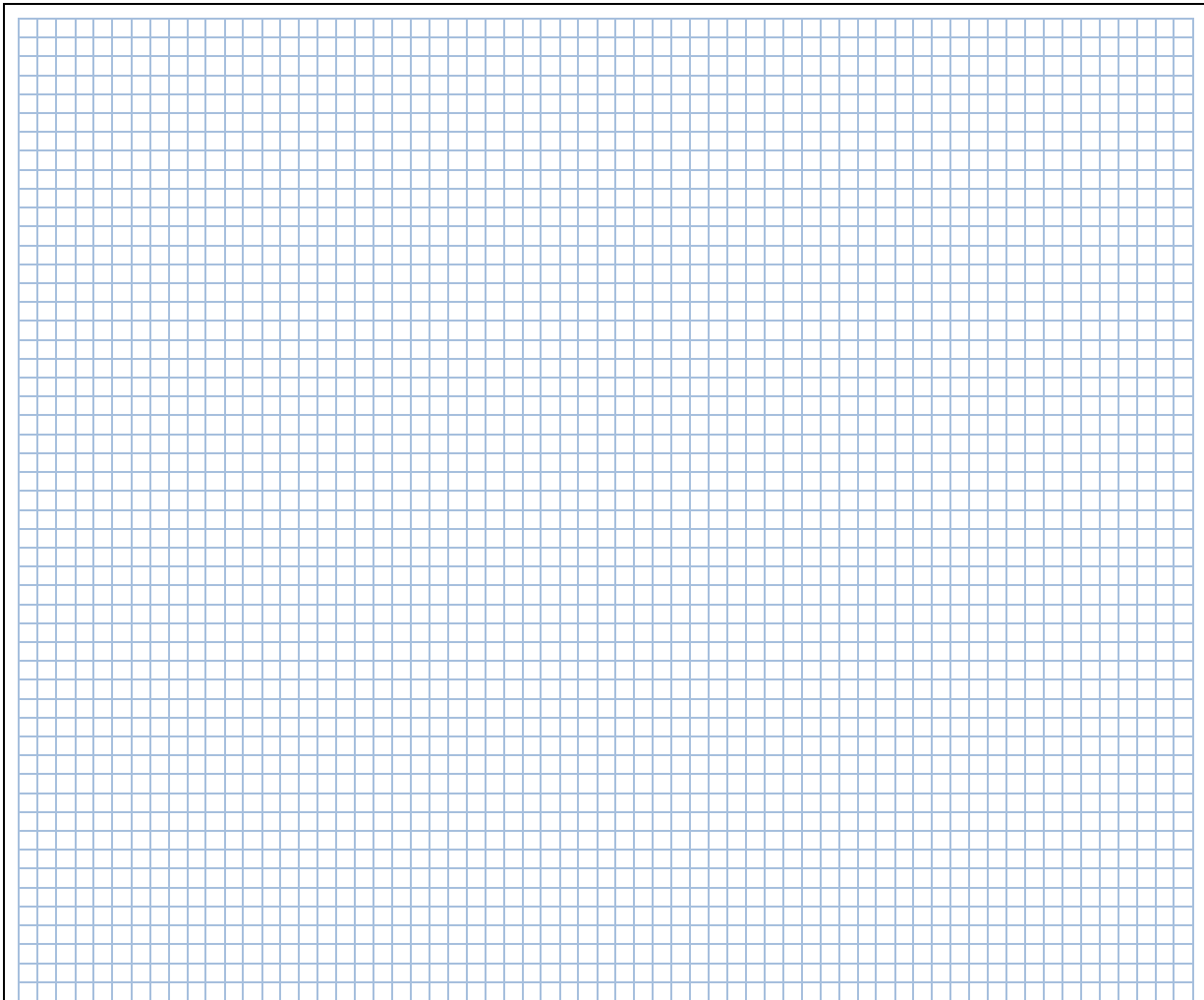

c) Use your graph to solve the roots of the quadratic equations.

i) $2x^2 + x - 5 = 0$

[2 Marks]

ii) $2x^2 + 3x - 2 = 0$

[2 Marks]

iii) $x^2 + 4x - 3 = 0$

(1 mark)

FORM 3 ENDTERM 2 EXAMS

ENGLISH

PAPER 1

TIME:2 HOURS

(Functional writing, cloze test and oral skills.)

NAME..... ADM NO:.....

SIGN..... DATE;.....

1. You are the secretary of Umoja Faith Church Youth Group. The group is planning to hold a meeting on 16th August 2015 whose main agenda will be the Mission Outreach and initiating income generating activities. The constitution stipulates that there must be a 21-day notification of the meeting.

- i) Write a notice of the meeting that will be sent to the members. **6 marks**
- ii) During the meeting, 8 members were present, 3 including the treasurer sent apologies and the whereabouts of 2 members were unknown. The youth pastor attended the meeting. Apart from the main issues, members raised some matters from the previous meeting. There were also some personal issues raised by some members.
Write down the minutes of the meeting. **14 marks**

.....

.....

.....

.....

.....

.....

.....

.....

.....

.....

.....

.....

.....

.....

.....

.....

.....

.....

.....

.....

.....

.....

.....

.....

.....
.....
.....
.....
.....
.....
.....
.....
.....
.....
.....
.....
.....
.....
.....
.....
.....
.....
.....
.....
.....
.....
.....
.....
.....
.....
.....
.....
.....
.....
.....
.....
.....
.....
.....
.....
.....
.....
.....
.....
.....
.....
.....
.....
.....
.....
.....
.....
.....

.....

.....

.....

.....

.....

.....

.....

.....

.....

.....

.....

.....

.....

.....

.....

.....

.....

.....

.....

.....

.....

.....

.....

.....

.....

.....

2. Read the passage below and complete each blank space with an appropriate word 10 marks

Citizens used to i)..... that political leaders would observe the principles of good governance simply ii).....they were expected to. iii).....; it appears most leaders on the continent have replaced integrity with reckless impunity that has iv)..... Africa in chaos. v).....office are also supposed to be vi)..... to the people that entrusted them with the vii).....of leading them. viii)....., the political elite in the continent see people as a means to an end. In many countries these days, Kenya included, politics has become the easiest way to make money. Electioneering is seen as an ix).....with extremely lucrative returns when campaign loyalties are x).....with appointments in the government of the day.

3. a) Read the following Ankole song and answer the questions that follow.

Suck and I hide you, my gentle one	Suck and I hide you, my beloved
I dreamt that the hunt was at Buganga	I dream that the hunt was at Ngarama
Where, oh where, shall I put, my little baby?	Where, oh where, shall I put you, my lovely little lips?
If I put you in a clump of grass, my gentle one	The hunters' rough dog will come sniffing around
The hunters' thick club tears up the back	
Suck and I hide you, gentle one	Suck and I hide you, for whom the drum sounds
Where, oh where, shall I put you, my lovely little lips?	Where, oh where, shall I put you, my beloved?
If I put you by the wayside, gentle one	Passers-by will take you with them, my beloved
If I put you in an anthill, my little baby	The ants will enclose you in their nest,
lovely little lips	Suck and I hide you, little baby
	Suck and I hide you, my gentle one
When I am dead and gone, gentle one	Feed on little blades of grass like cow, my beloved
And wash them down with a little water, my little baby	That's what raises orphans, you for whom the drum sounds
If I do not die, my little baby	
Good things will be ours to enjoy, you for whom the drum sounds	

i) Identify aspects of oral performance that make this song easy to remember? 2 marks

.....

.....

.....

.....

.....

.....

(ii) In what ways would this song be made interesting to listen to? 2 marks

.....

.....

.....

.....

.....

.....

(iii) How would you perform the last two lines of the above song? (2 marks)

.....

.....

.....

.....
.....
.....

b) **Study the genre below and answer the questions that follow**

I have a wife everyone she bears has a bead

- i) Identify the genre under which the above item falls. 1 mark
- ii) Assuming you were to perform this genre, what will you do before the presentation? 1 mark
- iii) How will (ii) above assist you as a presenter? 1 mark
- c) *Identify the silent letters in the words below* 3marks

- i) Shepherd
- ii) Rendezvous
- iii) Epistle

d) *Write another word that has the same pronunciation as the following words* 3marks

- i) Mark
- ii) Broach
- iii) Proof

e) Underline the stressed the syllables in the highlighted words 2 marks

- i) We have to *relocate* these people
- ii) The security officer will *punish* you if you come late.

f) *Indicate whether the following sentences have a falling or a rising intonation.* 2 marks

- i) A stitch in time saves nine
- ii) Do you like tomatoes or not.
- g) Jaramba's son, Mariapa, was really enthusiastic to go for a party with his friends at Carnivore. He had been invited to a friend's birthday party. He had to get permission from the father first in order to attend. However, Mariapa failed to convince his father because of his approach and language. What could have been the weaknesses in his negotiation skills? 5 marks

h) *Read the conversation below between Audrey, a student, and the school secretary then answer the questions that follow.* 6 marks

Audrey: Hallo. Good morning.

Secretary: Hallo. Who is on the line and what do you want?

Audrey: I am a Form 4Y student and I have been away from school for three days now. May I speak to the Principal?

Secretary: The Principal is not in the office now.

Audrey: Could I please leave a message for him?

Secretary: Oh, please, don't you have his cellphone number?

Audrey: No madam, since it is official, kindly take down the...

Secretary: Excuse me, young girl, I am too busy for this idle chat.

Audrey: I am sorry but it is very urgent, madam.

Secretary: (*without a pen or paper*) Go ahead and you better be quick.

Audrey: Thanks for the attention

i) *Identify the weaknesses in the secretary's telephone conversation skills. 3marks*

.....

.....

.....

.....

.....

.....

(ii) *What should she do to improve on this?*

3marks

.....

.....

.....

.....

.....

.....

FORM 3 ENDTERM 2 EXAMS

ENGLISH

PAPER 2

TIME:2 HOURS

NAME..... ADM NO:.....

SIGN..... DATE;.....

101/2
ENGLISH
PAPER 2
TIME: 2 HOUR

FORM THREE ENGLISH

101/2
ENGLISH
PAPER 2
TIME: 2 HOUR

Instructions to candidates.

- Answer ALL the questions only

For Examiners Use Only

Question	Maximum score	Candidate's score
1.Comprehension	20	
2.Literary Appreciation	25	
3.Poetry	20	
4.Grammar	15	
Total score	80	

**i) Read the passage below and answer the questions that follow
(20mks)**

WORRY has completely defeated me. My mind was so confused and troubled that I could see no joy in living. My nerves were so strained that I could neither sleep at night nor relax by day. My three young children were widely separated, living with relatives. My husband was in another city trying to establish a law practice. I felt all the insecurities and uncertainties of the post-war readjustment period.

I was threatening my husband's career, my children natural endowment of a happy, normal home life, and I was also threatening my own life. My husband could find no housing, and the only solution was to build. Everything depended on my getting well. The more I realized this and the harder I would try; the greater would my fear of failure. Then I developed a fear of planning for any responsibility. I felt that I could no longer trust myself. I felt I was a complete failure.

When all was darkest and there seemed to be no help, my mother did something for me that I will never forget or cease being grateful for. She shocked me into fighting back.

She upbraided me for giving in and for losing control of my nerves and my mind, she challenged me to get up out of bed and fight for all I had. She said I was giving in to the situation, fearing it instead of facing it, running from life instead of living it.

So I did start fighting from that day on. That very weekend I told my parents they could go home, because I was going to take over; and I did what seemed impossible at the time. I was left alone to care for my two younger children. I slept well. I began to eat better, and my spirits began to improve.

A week later when they returned to visit me again, they found me singing at my ironing. I had a sense of well-being because I had begun to fight a battle and I was winning. I shall never forget this lesson..... if a situation seems insurmountable, face it! Start fighting! Don't give in.

From that time on I forced myself to work, and lost myself to work. Finally I gathered my children together and joined my husband in our new home. I resolved that I would become well enough to give my family a strong, happy mother. I became engrossed with plans for my children, plans for my husband, and plans for everything except for me. I became too busy to think of myself. And it was that the real miracle happened.

I grew stronger and stronger and could wake up with the joy of well-being, the joy of planning for a new day ahead, the joy of living. And although days of depression did creep in occasionally after that, especially when I was tired, I would tell myself not to think or try to reason with myself on those days and gradually they became fewer and fewer and finally disappeared.

Now, a year later, I have a very happy, successful husband, a beautiful home that I can work in sixteen hours a day, and three healthy, happy children and for myself , peace of mind.

(Adapted from “How to stop worrying and start living”)

Questions

- (a) Give **five** effects of worry on the writer. (5mks)
- (b) What do you think was the cause of the writer’s worry. (2mks)
- (c) Describe the element of **irony** in the writer’s life. (3mks)
- (d) How does the writer get out of this terrible situation? (2mks)
- (e) What **steps** does the writer undertake to overcome the problem? (4mks)

(f) In a paragraph of about **60 words** explain the benefits of the writer's efforts to overcome worry.
(4mks)

2. Read the following excerpt and answer the questions that follow

However, the notion that he was about to hand over his own daughter to a gangster continued to **gnaw** at the conscience of Ole Kaelo relentlessly. He felt guilty, especially when he recalled the atrocities that were known to have been committed by Oloisudori over the years. But another voice told him quietly that he was being foolish and unreasonable to question his own conscience over the matter of Oloisudori, for he was just one among many who were enjoying the fruits of their labour. And it was hardly anybody's business to know how honest that labour was. After all, the small voice reassured him tauntingly, those who committed bigger crimes such as Goldenberg and Anglo-leasing, were still enjoying the 'fruits of their labour.' Had they not invested the yields of their ill-gotten money in housing estates, in shares, in import and exports in tourism, in transport and in other trades, just as Oloisudori had done?

When he went to bed later that evening, he remained awake for many hours **pondering** over those disturbing thoughts that went through his mind fleetingly, like water that churned violently in a turbulent sea. He thought of Oloisudori's **impending visit** and his intended marriage to Resian. He knew the success or failure of the event would determine the fate of his business. Even his continued ownership of that house where he and his family lived, depended on the outcomes of that event. Should Oloisudori fail to get Resian and recall the loan he had extended to him to buy that house, **he was done**. And knowing Oloisudori, he could very easily draw the rug from beneath his feet, leaving him vulnerable to all kinds of vagaries. And the thoughts gave him anxious moments.

At dawn when sleep overtook him, Ole Kaelo had a pleasant dream. Resian had consented to Oloisudori's proposal. After Oloisudori reported that to him, he was greatly pleased and relieved. His wife was rapturous. Although they were astonished at the turn of events, they were relieved to know that they would not have to live with the guilt of having forced their daughter to get married. What a wise child his once hardheaded daughter had turned to be after all! And how devious! After all those years of sullenness, awkwardness and tactlessness, she had finally brought relief to their life and ushered in a period of peace and tranquility. But then, it was just that. A dream!

FOR MARKING SCHEMES CALL/WHATSAPP 0746 222 000

Questions

a).Place the excerpt in its **immediate** context.

(4mks)

b).Discuss three **major issues** in this excerpt.

(6mks)

c).Discuss two character **traits** of ole kaelo in this excerpt.

(4mks)

d).“and the thoughts gave him anxious moments” (**add a question tag.**)

(1mk)

e).Discuss any **three aspects** of **style** in this excerpt.

(6mks)

f). Explain the **meaning** of the following expressions from the excerpt. (4mks)

- (i). Gnaw.....
- (ii). Pondering.....
- (iii). Impending visit
- (iv). He was done.....

3. Read the following **oral poem** and then answer the questions which follow

O elephant possessor of a saving- basket full of money
O elephant, huge as a hill, even in a crouching posture,
O elephant, enfolded by honour:demon, flapping fans of war.
Demon who snaps tree branches into many pieces and moves on the forest farm,
O elephant, whom ignores ' I have fled to my father for refuge'.
Let alone 'to my mother'Mountains Animal, Huge
Best who tears a man like a garment and hangs him up on a tree,
The sight of whom causes people to stampede towards a hill of safety,
My chant is a salute to the elephant ,Ajanaku who walks with a heavy tread,
Demon who swallows palm-fruit bunches, whole, even with the spiky pistil –cells,
O elephant, praise named, Laaye, massive animal blackish –grey in complexion,
O elephant, who single-handed cause a tremor in a dense tropical forest,
O elephant, who stands sturdy and alert, who walks slowly as if reluctantly,
O elephant, whom one sees and points towards with all one's fingers.
The hunters boast at home is not repeated when he really meets the elephant.
The hunters boast at home is not repeated before the elephant,
Ajanaku looks back with difficulty like a person suffering from a sprained neck.

FOR MARKING SCHEMES CALL/WHATSAPP 0746 222 000

The elephant has a porter's – knot without having any load on his head.

The elephant's head is his burden which he balances,

O elephant, praise named, Laaye, O death, please stop following me.

This part and parcel of the elephant's appellation.

If you wish to know the elephant, the elephant who is a veritable ferry –man.

The elephant whom honuor matches, the elephant who continually swings his trunk.

His upper fly-switch.,It's the elephant whose eyes are veritable water –jars,

O elephant, the vagrant par excellence.

Whose molar teeth are as wide as palm- oil pits in Ijesaland,

O elephant, lord of the forest, respectfully called Oriiribobo

O elephant whose teeth are like shafts,One tooth of his a porter's load,

O elephant fondly called Otiko,Who has a beast- of burden's proper nock,

O elephant, whom the hunter at other times aces face to face.

O elephant, whom the hunters at other times seas from the rear.

Beast who carries mortars and yet walks with a swaggering gaint.

Primeval leper, animal treading ponderously.

Questions

(a) What **type of** oral poem is this?

(2mks)

(b) Identify, illustrate and give the effect of any **three** features of style used in the poem.(6mks)

(c) How is the elephant **portrayed** in the poem? (2mks)

(d) What is the **persona's attitude** towards the elephant? (2mks)

(e) Identify any **two** economic activities of the community from which this poem is derived. (4mks)

(f) Identify the main **theme** of this poem. (2mks)

(g) Explain any **two** problems you may encounter when collecting material for this genre. (2mks)

4. Grammar

a). **Rewrite** the following sentences as instructed (2mks)

1. My examination results were released only after I had cleared the fee balance. **(Begin: Not until.....)**

2. If I were the Minister for National Security, I would ensure tighter security checks at the borders.

(Begin: Were I)

3. They had handled the case so carelessly that we were not satisfied. **(Begin : So ...)**

FOR MARKING SCHEMES CALL/WHATSAPP 0746 222 000

4. "I shall expect to see you next Wednesday," the teacher told the student. (*Write in reported speech.*)

b). Use the **correct form** of the word in brackets in the sentences that follow. (3mks)

i. The modern world today has manyforms of communication

(**sophistication**)

ii The gas was stored in acontainer (**pressure**)

iii. Do not wait for the bus, it comes to this town very (regular).

c). Give the **meaning** of the underlined **idiomatic expression**. (2mks)

(i) The teacher asked him to stop beating about the bush.

(ii) The politicians asked them to cross the bridge when they reach it.

d). Choose the correct **pronoun** in the following sentences.

(2mks)

vi) She knew all about my friend and _____(I/me)

vii) What would you do if you are _____? (she/her)

e). Complete each blank space in the following sentences with **appropriate choice** from:
(*few, a few, little, a little, some*) (2mks)

(q) If there is tea left in that flask, I would like to have_____

(r) Since animal proteins are very expensive_____people eat enough

f) .Replace the underlined word with the correct **phrasal verb**. (2marks)

1.The class teacher promised to solve the problem. (sort)

2.He tried all his dirty tricks on us but he did not succeed . (come)

3. The nurse couldn't tolerate the noise

4.The mayor assumed that the problem had been got rid of.

g). Rewrite the sentences below as to remove **gender bias**. (1mks)

1. The headmistress advised her girls to keep off drugs.

2. The father left his sons and daughters a big estate.

FORM 3 ENDTERM 2 EXAMS

ENGLISH

PAPER 3

TIME:2 ½ HOURS

NAME..... ADM NO:.....

SIGN..... DATE;.....

1. COMPULSORY: IMAGINATIVE COMPOSITION (20 MARKS)

Either,

a) Write a story beginning with the words:

I had not thought it was a big problem until I got involved

Or

b) Discuss the measures you would take to curb flooding in our Kenyan urban areas.

2.The Compulsory Set Text.

“Self-interest is a vice that whoever engages in it is bound to fail.” Using *Blossoms of the Savannah*, write an essay to support this assertion. (20 marks)

3. THE COMPULSORY SET TEXT

A DOLL’S HOUSE by Henrik Ibsen

(20 marks)

“Love all, trust none.” Show how this is portrayed using illustrations from the play, “A

FORM 3 ENDTERM 2 EXAMS

KISWAHILI

PAPER 1

TIME:1 ¾ HOURS

NAME..... ADM NO:.....

SIGN..... DATE;.....

102/1

KISWAHILI

KARATASI YA 1

(INSHA)

KIDATO CHA TATU

MUDA: SAA 1 ¾

MAAGIZO

1. Andika Insha **mbili**
2. Swali la **kwanza** ni la **lazima**
3. Chagua insha nyingine kutoka hizo tatu zilizobaki
4. Kila insha isipungue maneno **400**
5. Kila insha ina alama **20**

Watahiniwa wanastahili kuona kuwa maswali yote yako na hakuna yaliyoachwa.

Jibu maswali mawili, swali la kwanza ni la lazima.

1. Halmashauri ya utunzi wa mitihani nchini imewatahadharisha watahiniwa dhidi ya udanganyifu katika mitihani ya kitaifa. Andika tahadhari hiyo na hatua zitakazochukuliwa dhidi ya watakaozikiuka.
2. Katiba mpya imewapa vijana uhuru wa kujitegemea na kujiendeleza kimaisha. Thibitisha
3. Pilipili usiyoila yakuashiani?
4. Andika hadithi itakayomalizikia kwa:
.....kisa hiki kilinifundisha kwamba kuzaliwa masikini si hoja.

FORM 3 ENDTERM 2 EXAMS

KISWAHILI

PAPER 2

LUGHA

TIME:2 HOURS

NAME..... ADM NO:.....

SIGN..... DATE;.....

Kwa matumizi ya mtahini pekee

	Upeo	Alama
1. Ufahamu	15	
2. Ufupisho	15	
3. Matumizi ya lugha	40	
4. Isimujamii	10	
Jumla	80	

Kila mtahiniwa lazima aangalie kama kurusa zote za karatasi hii zimepigwa chapa sawasawa na kuwa maswali yote yamo

1. **Soma taarifa ifuatayo kisha ujibu maswali.**

Habari kuwa watoto chini ya miaka mitatu ‘huwindwa’ kitandani na kuraushwa na wazazi wao waende shuleni mwendo wa saa kumi na moja asubuhi ni za kusikitisha.

Kwa mujibu wa ripoti za wataalamu wa elimu ya watoto wachanga (ECD), watoto hao hutakikana kuwa darasani kabla ya saa kumi na mbili asubuhi.

Wanapowasili wao huanza kufukuza ratiba ya masomo ambayo huwapatia muda mfupi mno wa kula, kucheza, kupumzika na hata kuchunguza afya na usalama wao.

Badala ya kuondoka mapema kuelekea nyumbani, wengi wao hufika saa za usiku pamoja na wazazi wao wakitoka kazini. Wanapowasili nyumbani wanapaswa kuoga na kupata chakula cha jioni kwa pupa ili wafanye mazoezi waliyopewa na walimu wao.

Mazoezi hayo huwa ya masomo yote matano huku kila somo likiwa na zaidi ya maswali thelathini. Badala ya kupumzika mwishoni mwa juma, watoto hao huhitjika kuhudhuria shule siku nzima ya Jumamosi. Jumapili wanatakiwa Kanisani na hali hii hujirudia mpaka muhula umalizike.

FOR MARKING SCHEMES CALL/WHATSAPP 0746 222 000

Ikiwa ulidhani watapewa nafasi ya kupumzika wakati wa likizo , umekosea kwa sababu watoto hao huhitajika kuhudhuria shule. Hili limekuwa likiendelea hata baada ya Wizara ya Elimu kupiga marufuku kusomesha wakati wa likizo.

Wazazi-hasa wale wanaofanya kazi mijini- wamekuwa wakiunga mkono mtindo huu kwa sababu unawaondolea mzigo wa malezi na gharama ya kuwaajiri walezi.

Wataalamu wanasema matokeo ya hali hii ni watoto **wakembe** wenye afya na **maadili** mabaya kutokana na kuchanganyishwa akili na walimu wanaowataka wajue kila kitu wakiwa na umri mdogo.

Kuwashinikiza watoto wakembe wahudhuria shule na zaidi ya hayo wajue kila kitu kuna madhara mengi. Kwanza kabisa, kuraushwa kwa watoto macheo waende shule kunawanyima fursa ya kulala na kupumzika. Utafiti unaonyesha kuwa watoto wanahitaji kulala na kupumzika kwa zaidi ya saa 12 kwa siku. Hii ina maana kuwa mbali na muda mfupi wanaolala na kupumzika mchana kutwa, watoto wanapaswa kutumia usiku mzima kwa usingizi.

Hii huwasaidia kukua wakiwa na afya nzuri hasa kiakili. Matokeo ya kuwarausha watoto hao waende shule saa hizo huwafanya wakose furaha mbali na kuwafanya wachanganyikiwe kiakili.

Pili, kuwalazimisha watoto wakae darasani kuanzia saa kumi na mbili asubuhi hadi saa kumi na mbili jioni huwa kunawanyima fursa ya kucheza na kutangamana. Wataalamu wa afya ya watoto wanapendekeza kuwa watoto wachanga wanapaswa kucheza ili viungo vya miili yao kama moyo, akili, mapafu na kadhalika vifanye kazi vizuri.

Kinyume na watu wazima ambao hufanya kazi nzito nzito na kuwawezesha kufanya mazoezi, watoto huwa hawafanyi kazi hizo. Wazazi na walimu wanapaswa kufahamu kuwa kazi ya watoto ni mchezo na wana kila haki ya kupewa furaha ya kucheza wakiwa shuleni na hata nyumbani.

Tatu, wazazi wengi ambao hufurahia kuwaachia walimu jukumu la kuwalea watoto wao huku wao wakiwa kazini huwa wanasahau kuwa sio kila mwalimu ana maadili yanayopaswa kuigwa na mwanawe. Ingawa tunawatarajia walimu wawe mifano bora ambayo inaweza kuigwa na kila mtu, ukweli ni kwamba baadhi ya walimu hawajui maana wala hawana maadili. Hatari ni kwamba watoto **wakembe** husoma kwa kuiga wakubwa wao na ikiwa walimu wanaoshinda nao shule wamepotoka kimaadili, kuna uwezekano mkubwa wa watoto hao kupotoka pia. Hii ndiyo sababu wazazi wengi wamekuwa wakilalamika kuwa wanawao tabia mbaya ambazo hawaelewi zilipotoka.

Kila mzazi anayejali maisha ya mwanawe anapaswa kutekeleza jukumu lake la kumlea na kumwelekeza jinsi anavyotaka akue. Ni kinaya kuwa wanawatarajia wanawao wawe na tabia na maadili kama yao ilhali hawachukui muda wa kukaa nao na kuwaelekeza.

Nne, kuwawinda, kuwaamsha, kuwaosha na kuwalazimisha watoto waende shule kila siku hata ingawa hawataki huwa kunawafanya wawe wategemezi wasioweza kujipangia na kutekeleza mambo kivyao.

MASWALI.

(a) Ipe taarifa anwani mwafaka. (alama 2)

(b) Mwandishi anatoa maoni gani kuhusu ratiba ya masomo? (alama 2)

(c) Eleza athari za mfumo wa elimu unaoangaziwa hapa. (alama 3)

(d) Ni ushauri upi unaotolewa kwa wazazi ? (alama 2)

(e)Taja mbinu zozote **mbili** za lugha alizotumia mwandishi (alama 2)

(f) Eleza **maana** ya maneno haya kama yalivyotumiwa katika taarifa. (alama 4)

(i) **'huwindwa' kitandani**

(ii) **Maadili**

(iii) **Kuwashinikiza...**

(iv) **Wakembe...**

1. Soma taarifa kisha fupisha kwa mujibu wa maswali yafuatayo.

Uwezo wa kuyakumbuka mambo ni hazina kuu kutoka kwa mtu yeyote yule aliye hai. Uwezo huu wa kukumbuka ni mojawapo ya shughuli changamano za ubongo. Ubongo wa mwanadamu hutekeleza shughuli hii kwa namna tatu. Kwanza ubongo hunasa jambo kisha huliifadhi. Baadaye huanzisha mfumo wa kutoa kilicho hifadhiwa. Ubongo ukiathirika kwa namna yeyote katika moja wapo ya njia hizi, basi uwezo wa kuyakumbuka mambo huvurugika.

Ingawa inaaminika kuwa uwezo wa kukumbuka hurithishwa toka kizazi kimoja hadi kingine, wataalamu wa maswala ya kiakili wanabaini kuwa uwezo huu unaweza kuimarishwa. Uimarishaji huu huhitajika mikakati madhubuti.

Njia mojawapo ya kustawisha uwezo wa kukumbuka ni kupitia kwa lishe. Vyakula vilivyosheheni vitamini B vyenye amino asidi husaidia kuimarisha uwezo wa kukumbuka. Vyakula kama hivi ni mboga, nyama (hasa maini), bidhaa za soya, matunda, maziwa, bidhaa za ngano, samaki, pamoja na mayai. Vyakula vingine muhimu katika ustawishaji huu ni vile vyenye madini ya chuma. Madini haya huwezesha usambazaji wa hewa katika ubongo kwa wepesi. Vyakula ambavyo vina madina haya ni mboga za kijani, mawe, ndengu, soya, matunda kama maembe, ufuta (simsim) pamoja na nyama, hasa maini na mayai.

Ubongo wa mwanadamu aliye hai hufanya kazi kila wakati awe macho au amelala. Utendaji kazi wake huendeshwa na glukosi mwilini. Kwa hivyo, vyakula vyenye sukari hii ni muhimu kuliwa. Hata hivyo, lazima mtu awe mwangalifu na kuhakikisha kuwa mwili una kiwango cha sukari kisicho hatarisha maisha. Haya yanawezekana kwa kula vyakula vyenye nyuzinyuzi kama vile mboga na matunda.

Njia ya pili ni kupiga marufuku vileo kama pombe na nikotini. Vileo hivi huathiri utaratibu wa kunasa, kuhifadhi na kutoa yaliyo ubongoni.

Iwapo mtu ana tatizo la kuyakumbuka majina ya watu, ni muhimu kufanya mazoezi ya kusikiliza kisha kurudia majina hayo wakati wa mazungumzo. Ni bora kulihusisha jina na sura

ya mtu. Kwa njia hii ubongo utanasa jina na kile kinacholengwa.

Woga na kuvurugika kiakili ni mambo mengine tunayopaswa kuepuka kila wakati. Ni kawaida mtu kupata woga wakati anapokabili jambo asilokuwa na uhakika na matokeo yake kama mtihani au mahojiano. Lakini anapaswa kuwa makini. Woga huo usikiuke mpaka na kumvuruga kiakili. Vurugu hizi huathiri kilichohifadhiwa ubongoni na pia namna ya kukitoa.

Halikadhalika, mwili wenye siha nzuri huhakikisha kuwa ubongo ni timamu. Wataalamu wengi wa siha wanakubali kuwa na mazoezi ya kunyoosha viungo hustawisha ubongo na hivyo kuhakikisha kuweko kwa uwezo wa kukumbuka mambo. Ni muhimu kuwa na taratibu ya kunyoosha viungo kila wakati. Fauka ya hayo, mazoezi ya kiakili, kama vile kusoma makala yanayovutia, kujaza mraba na michezo mingine kama mafumbo, vitenzi ndimi ni muhimu katika kustawisha uwezo wa kukumbuka.

Jamii ya watu wenye uwezo kuyakumbuka mambo ni ya jamii iliopiga hatua kimaendeleo. Ni jukumu la kila mmoja wetu kuimarisha uwezo wa kukumbuka kila wakati.

Maswali:

- a) Kwa maneno 60 – 65 fupisha mchango wa chakula katika uimarishaji wa uwezo wa kukumbuka.(alama 6 ,2 mtuliliko) **Matayalisho**

Nakala safi

- b) Fupisha aya tatu za mwisho kwa maneno 80 – 90 (alama 7)
Matayarisho

Nakala safi

3. MATUMIZI YA LUGHA

(a) **Andika sifa bainifu za sauti.**

(alama 2)

(i) e:-

(ii) n:-

(b) **Eleza maana ya :-**

(alama 2)

(i) Kiimbo.

(ii) Shadda.

(c) **Tunga sentensi moja moja kudhihirisha ngeli zifuatazo:-**

(alama 2)

(i) U-U

(ii) Pokomo /Pa-ku-mu

(d) **Unda kitenzi kimoja kutokana na nomino ‘Mtubia’**

(alama 2)

(c) **Eleza matumizi mawili ya kiambishi ‘ku’**

(alama 2)

FOR MARKING SCHEMES CALL/WHATSAPP 0746 222 000

- (f) Tunga sentensi ya maneno manne ambayo ina sehemu zifuatazo. Kielezi cha namna, kivumishi, kitenzi na jina (alama 2)
- (g) **Yakinisha sentensi ifuatayo;** (alama 2)
Mvua haijanyesha vizuri msimu huu.
- (h) **Onyesha matumizi mawili mawili ya alama zifuatazo:-** (alama 2)
(a) Alama ya mshangao

(b) Mshazari
- (i) **Tunga sentensi sahihi ukitumia –wa- katika kauli ya kutendelea** (alama 2)
- (j) **Andika udogo wa sentensi:-** (alama 2)
Ndama wa ng'ombe yule ameuzwa.
- (k) **Onyesha tofauti ya vitate vifuatavyo kwakuvitungia sentensi** (alama 2)
(i) Dhamani
(ii) Thamani
- (l) **Kanusha sentensi ifuatayo katika wingi** (alama 2)
Ningalikuwa na pesa ningalinunua gari
- [m] **Tumia neno “shujaa” katika sentensi kama:-** (alama 2)
(i) Kivumishi

(ii) Kielezi.
- (n) Huku ukitumia mifano mwafaka, eleza tofauti ya sentensi sahili na ambatano (alama 4)
- (o) **Onyesha aina za viambishi katika sentensi hii:** (alama 2)
Nitajisomea

(p) **Andika katika usemi wa taarifa:-** (alama 2)
Tutaanza mashindano kesho, Mwalimu alimwambia mwanafunzi.

(q) **Eleza maana mbili ya sentensi:-** (alama 2)
Tumetengeneza barabara

(r) **Tumia mifano mwafaka kueleza aina za mofimu** (alama 2)

(s) **Changanua kwa njia ya mishale**
Mama analima shambani.

4. ISIMU JAMII

Soma mzungumzo yafuatayo kisha ujibu maswali :

- A :** Ohh, dada Naomi
B : Dada Ruth (anamsogea kwa bashasha wanakumbatiana). Ahh Mungu asifiwe!
A: Asifiwe sana
B: Ehh dadangu, miezi ...mingi...sijakuona
A: dada wee...Nilitumwa huko kusini ...Kuwahubiria watu injili (mtuo mdogo)singeweza kukata...
B: Ehh, usiwe kama Yona
A: Habari ya siku nyingi?
B: Nzuri Mungu bado ameendelea kunibariki
A: Amen!
B: Nimeendelea kuiona neema yake
A: Amen! Asifiwe Bwana
B: Halleluya
A: Ni Mungu wa miujiza!
B : Amen. Hata nami nimeona neema yake
Bado niko imara katika wokovu katika siku hizi za mwisho
A : Amen !
B : Ni Mungu wa ajabu kweli !
A : Nilikumbana na matatizo lakini nikategemea sala
Kama Paulo na sila... Na nikashinda (anatua). Sikuweza kumpa
shetani nafasi...maana ameshindwa
B : Ameshindwa kabisa

Maswali:-

(i) Hii ni sajili ya wapi ? Fafanua [alama 2]

(ii) Taja na ueleze sifa za sajili hii [alama 6]

(iii) Taja mambo **mawili** muhimu yaliyosaidia katika maenezi ya Kiswahili Afrika mashariki na kati. [Alama 2]

FORM 3 ENDTERM 2 EXAMS

CHRISTIAN RELIGIOUS EDUCATION

PAPER 1

TIME:2 ½ HOURS

NAME..... ADM NO:.....

SIGN..... DATE;.....

ANSWER ANY FIVE QUESTIONS

1. (a) Identify seven teachings on the relation between human beings and the environment from Genesis stories of creation.
(7mks)
(b) With reference to the story of the fall of human in Genesis 3, state the effects of sin on Adam and Eve.
(8mks)
(c) State five consequences of breaking taboos in traditional Africa communities.
(5mks)
2. (a) Describe the covenant ceremony between God and Abraham. (Genesis 15:1-9)
(8mks)
(b) State the characteristics of the covenant between God and Abraham.
(7mks)
(c) Identify five lessons that Christians learn about God from the call of Abraham. (5mks)
3. (a) Describe the contest between prophet Elijah and prophet of Baal at Mount Carmel (1st Kings 18:17-40) ()
(b) State seven problems faced by Prophet Elijah in Israel.
(7mks)
(c) Identify qualities of Prophet Elijah that a Christian leader should possess.(
4. (a) State five ways in which prophetic messages were compiled.
(5mks)
(b) Outline the message of hope that prophet Amos gave to Israel if they turned to God.
(7mks)
(c) Give reasons why Christians repent their sins.
(8mks)
5. (a) Outline six response that Jeremiah made to God during his call Jere 1:4-19
(6mks)
(b) Show how the letter Jeremiah wrote to the exiles gave them hope for restoration. Jere. 29:4-15
(7mks)

(c) Suggest seven reasons why Christians should accept pain and suffering in their daily lives.

(7mks)

6. (a) Name the specialists in traditional African Communities. (5mks)

(b) Explain reasons why cleansing rituals were performed in Traditional African Communities.

(8mks)

(c) Outline seven reasons why the church is opposed to female genital mutilation. (F.G.M.)

(7mks)

FORM 3 ENDTERM 2 EXAMS

CHRISTIAN RELIGIOUS EDUCATION

PAPER 2

TIME: 2 ½ HOURS

NAME..... ADM NO:.....

SIGN..... DATE;.....

Answer any five questions from this paper.

1. (a) Outline Isaiah's prophecy on the suffering servant. (Isaiah 53) (7 mks)
(b) Describe the annunciation of the birth of John the Baptist (Luke 1:5-25) (8 mks)
(c) State five ways in which a Christian couple should respond to childlessness. (5 mks)

2. (a) Describe the commissioning of the Twelve Disciples of Jesus according to Luke 9:1-9 (8 mks)
(b) Give six reasons why Jesus faced opposition from the Pharisees and the scribes during his Galilean ministry. (6 mks)
(c) State six ways in which Christians are taking care of the needy. (6 mks)

3. (a) Outline the preparations made towards the celebration of the last supper. (7 mks)
(b) Relate the parable of the prodigal son Luke 15:11-32. (7 mks)
(c) State the lessons learnt about God from the parable of the prodigal son. (6 mks)

4. (a) Outline Paul's instructions on the use of spiritual gifts for the purpose of order in the church. (7 mks)
(b) In what ways was unity demonstrated by Christians in the early church? (7 mks)
(c) State six factors that threaten unity in the church today. (6 mks)

5. (a) Describe the call of the first disciples of Jesus. (7 mks)
(b) Give reasons why Christians should observe Jesus teaching on the cost of discipleship. (5 mks)

(c) With reference to the sermon on the plain describe four teachings of Jesus from the beatitudes.

(8 mks)

6. (a) Describe the body of Christ(Corinthians 12:12-27) (8 mks)

(b) What lessons can Christians learn from the events of the day of Pentecost? (5 mks)

(c) Outline seven ways in which the gift of prophecy is used in the church today. (7 mks)

FORM 3 ENDTERM 2 EXAMS

HISTORY AND GOVERNMENT

PAPER 1

TIME:2 ½ HOURS

NAME..... ADM NO:.....

SIGN..... DATE;.....
INSTRUCTIONS TO STUDENTS

- . a) This paper consists of three sections A, B and C. [L] [SEP]
- . b) Answer ALL the questions in section A, THREE in section B and TWO questions from section C [L] [SEP]

SECTION A : 25 MARKS

Answer all the questions in this section.

1. Give the *main* source of information on unwritten history (1mark)
2. Give *two* functions age set among the Agikuyu in pre-colonial Kenya. (2 marks)
3. Give *two* ways of interaction between Kenya societies in the 19th century. (2 marks)
4. Identify the name of the council of elders among Mijikenda community. (1 mark)
5. Why was 1957 elections in important in history of Kenya. (1 mark)
6. Give *two* contributions of the early missionaries in the field of education (2 marks)
7. Give *two* characteristics of a good constitution. (2 marks)
8. Identify *two* special groups whose rights are protected by Kenyan constitution. (2 marks)
9. State *two* reasons why colonial government encouraged settler farming in Kenya (2 marks)
10. Identify *two* communities that showed mixed reactions in Kenya. (2 marks)
11. Identify *one* reason why trade unions were not formed in Kenya by 1914. (1 mark)
12. Name *two* cash crop that Africans were prohibited from growing in colonial Kenya. (2 mark)

FOR MARKING SCHEMES CALL/WHATSAPP 0746 222 000

13. Name the body in charge of election in Kenya. (1 mark)
14. Identify *two* features of independent schools and churches in colonial Kenya. (2 mark)
15. Give the political parties that represented Kenya during the 2nd Lancaster House Conference of 1962.(2 mks)

Section B (45 marks)

Answer any three questions from this section

16. a) Give three reasons why early visitors came to the East African Coast. (3 marks)
- (b) Explain six factors which led to the decline of Coastal towns after 1500A.D (12 marks)
17. (a) Give *five* reasons why the Maasai collaborated with the British during the colonial period in Kenya.(5 ks)
- (b) Explain *five* reasons why the Nandi resisted the British for so long. (10 marks)
18. (a) Identify *five* results of Devonshire White Paper of 1923. (5 marks)
- (b) Explain *five* consequences of colonial land policies in Kenya. (10 marks)
19. (a) Give *five* characteristics of early political organizations in Kenya. (5 marks)
- (b) Explain five problems faced by trade union movements in Kenya during colonial period. (10 marks)

Section C (30 marks)

Answer any two questions from this section

20. (a) Name *five* members of African Elected Members Organization. (5 marks)
- (b) Describe *five* impacts of the First Lancaster House Conference of 1960. (12 marks)
21. a) State *three* methods that were used by African Nationalist during the struggle for independence.(3 marks)
- b) Explain the role of women in the Mau Mau movement. (12 marks)
22. (a) Identify *five* levels of conflicts (5 marks)
- (b) Explain *five* factors that promote national unity in Kenya. (12 marks)

FORM 3 ENDTERM 2 EXAMS

HISTORY AND GOVERNMENT

PAPER 2

TIME: 2 ½ HOURS

NAME..... ADM NO:.....

SIGN..... DATE;.....

INSTRUCTIONS TO CANDIDATES

- (s) This paper consists of **three** sections; **A, B** and **C**.
- (t) Answer **ALL** the questions in section **A**, **THREE** questions from section **B** and **TWO** questions from section **C**.
- (u) Answers to all the questions **MUST** be written on the answer sheets provided.

FOR EXAMINER'S USE ONLY

	QUESTION	SCORE
SECTION A	1 – 17	
SECTION B	18	
	19	
	20	
	21	
SECTION C	22	
	23	
	24	
TOTAL SCORE		

SECTION A (25 Marks)

(Answer ALL the Questions in this section)

1. State **two** arms of Government. (2 Mark)
2. Identify **one** theory explaining the origin of man. (1 Mark)
3. Name **two** species of Homo sapiens. (2 Marks)
4. Name any **two** centers of Agricultural Revolution. (2 Marks)
5. State the **two** main methods of trade. (2 Marks)
6. Give **two** examples of regional trade. (2 Marks)
7. Identify **two** means of transport that comprised early land transport. (2 Marks)
8. Identify the sailing ship used by the Greeks. (1 Mark)
9. Identify **one** early source of energy. (1Mark)

FOR MARKING SCHEMES CALL/WHATSAPP 0746 222 000

10. Give the major limitation of using water as a source of energy. (1 Mark)
11. List *two* factors for the growth of Meroe. (2 Marks)
12. Identify *one* historical building in Kilwa. (1 Mark)
13. Identify the symbol of national unity among the Shona. (1 Mark)
14. State *two* sources of the principles on which the British constitution is made. (2 Marks)
15. Name *one* missionary society that came to spread Christianity in Africa. (1 Mark)
16. State *one* function of Emirs in Northern Nigeria. (1 Mark)
17. Who was the first Prime Minister of India. (1 Mark)

SECTION B (45 Marks)

(Answer *Any Three* Questions from this section)

18. (a) State *five* stages of evolution of man before Homo erectus. (5 Marks)
- (b) Describe the way of life of human beings during the late stone age period. (10 Mark)
19. (a) Give *three* negative impacts of scientific inventions in agriculture. (3 Marks)
- (b) Explain factors that have hindered industrialization in Africa. (12 Marks)
20. (a) State *five* methods used by the British to colonize Buganda kingdom. (5 Marks)
- (b) What benefits did the Buganda people get as a result of their collaboration? (10 Marks)
21. (a) How did the attainment of independence of Ghana contribute to liberation of other African countries? (3 Marks)
- (b) Describe African Nationalists activities that intensified the struggle for independence in South Africa. (12 Marks)

SECTION C (30 Marks)

(Answer *Any Three* Questions from this section)

22. (a) Identify the privileges enjoyed by assimilated Africans in the four communes in Senegal (5 Marks)
- (b) Explain reasons why French policy of assimilation failed. (5 Marks)
23. (a) Outline three features of direct rule in Zimbabwe. (3 Marks)
- (b) What were the disadvantages of indirect rule system of administration? (12 Marks)
24. (a) State the terms of the Rudd Concession treaty of 1883. (3 Marks)
- (b) State six grievances of the Ndebele and the Shona during the Chimurenga war of 1896-1897 (12 Marks)

FORM 3 ENDTERM 2 EXAMS

GEOGRAPHY

PAPER 1

TIME: 2 ¾ HOURS

NAME..... ADM NO:.....

SIGN..... DATE;.....

SECTION A: (Answer all questions in this section)

- 1) (a) Give two components of the solar system. (2mks)
(b) State three effects of the movement of the earth around the sun. (3mks)
- 2) (a) How does a land breeze occur? (2mks)
(b) Name three ocean currents found on the coasts of West Africa. (3mks)
- 3) The diagram below represents a barchans, use it to answer question (a).

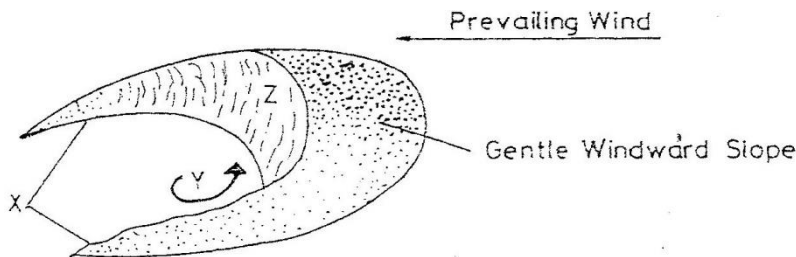

- l) (i) Name the feature marked X. (1mk)
(ii) The air current marked Y. (1mk)
(iii) The slope marked Z. (1mk)
- m) State two ways in which wind transports its loads. (2mks)

- 4) The diagram below shows a composite volcano.

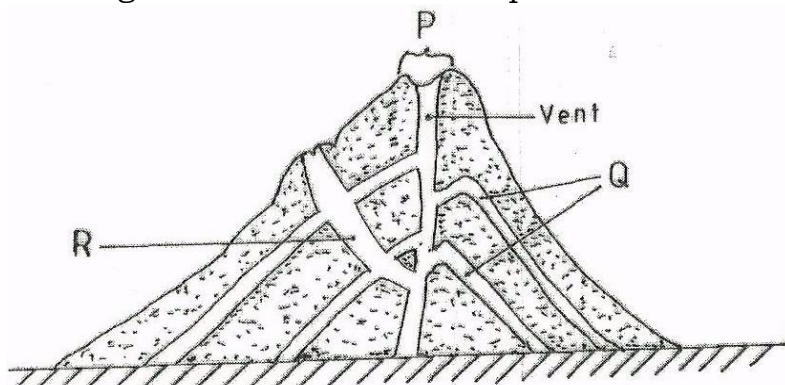

- xi) Name the features marked P, Q, R. (3mks)
 - xii) Give two ways in which vulcanicity influences human activities. (2mks)
- 5)** (a) What is the difference between ice sheet and ice berg? (2mks)
- (b) Name three types of glacier moraine. (3mks)

SECTION B:

Answer question 6 and any other TWO questions from this section.

- 6)** Study the map of Oyugis 1:50,000 (sheet 130/1) provided and answer the following questions.
- a)** (i) What is the four figure reference of Kokungu dam? (2mks)
- (ii) What is magnetic variation of the map? (1mk)
- (iii) Calculate the area covered by Koderia forest. Give your answer in square kilometer. (2mks)
- b)** Draw a square 10cm by 10cm to represent the area enclosed by Easting 84 and 94 and Northing 28 and 38. (1mk)

On the square, mark the name;

- e) Forest (1mk)
 - f) Swamp. (1mk)
 - g) District Boundary. (1mk)
 - h) Range. (1mk)
- c)** Describe the relief of the area covered by the map. (6mks)
- d)** Identify three social service of Kamangambo trading centre. (3mks)
- e)** Citing evidence from the map, explain three factors that favour farming. (6mks)

- 7)** (a) (i) Apart from the Rift valley, name other relief feature formed as a result of faulting. (3mks)
- (ii) With the aid of a well labeled diagram, describe how Rift Valley may have been formed by tensional forces. (8mks)
- (b) Explain three ways in which faulting influences drainage system. (6mks)
- (c) Explain four ways in which features resulting from faulting are of significance to the economy of Kenya. (8mks)

- 8)** (a) What is natural vegetation? (2mks)
- (b) Name the temperate grassland found in the following countries.

- i) Canada. (1mk)
- ii) Russia (1mk)
- iii) Australia. (1mk)

- (c) Explain how precipitation influences distribution of vegetation in an area. (4mks)
- (d) Describe the characteristics of the Savannah vegetation region. (6mks)
- (e) Give two reasons why Tundra region has scanty vegetation. (2mks)
- (f) You are planning to carry out field study in a forest within your district.

- viii) Give four reasons why it is important to seek permission. (4mks)
ix) Identify four challenges you are likely to encounter during the field study. (4mks)

- 9)** (a) (i) What is underground water? (2mks)
(ii) Explain how the following factors influence the presence of underground water.

- (a) Amount of rainfall. (2mks)
(b) Vegetation cover. (2mks)
(c) Slope gradient. (2mks)

- (b) (i) What is an artesian basin? (2mks)
(ii) State three conditions leading to the formation of artesian basin. (3mks)

- (c) (i) Identify three factors which influence the formation of Karst features. (3mks)
(ii) State four significance of Karst regions. (4mks)

(d) Your class is planning to carry out field study in a Karst landscape.

- d) Give two reasons why it is important to seek permission from the school authorities. (2mks)
e) Identify three challenges that you are likely to encounter during field study. (3mks)

- 10)** (a) What is a glacier? (2mks)
(b) Give two reasons why there are no ice sheets in East Africa. (2mks)
(c) Describe the formation of the following glacial features.

- a) Hanging valley. (6mks)
b) Arête. (6mks)

- (c) Name three erosional features found in glaciated lowland areas. (3mks)
(d) Explain three positive effects of glaciations in lowland areas. (6mks)

FORM 3 ENDTERM 2 EXAMS

GEOGRAPHY

PAPER 2

TIME: 2 ¾ HOURS

NAME..... ADM NO:.....

SIGN..... DATE;.....

INSTRUCTIONS TO CANDIDATES

- The paper consists TWO sections A and B.
- Answer ALL the questions in section A >
- In section B answer Question 6 and any other TWO questions from this section

SECTION A

ANSWER ALL QUESTIONS IN THIS SECTION.

1. (a) Name a mineral which occurs in each one of the following places in East Africa.

- i) Kwale in Kenya. (1mk)
- ii) Geita in Tanzania (1mk)
- iii) Kilembe in Uganda. (1mk)

(b) State two problems caused by dereliction of the land due to mining.
(2mks)

2. (a) Name three main areas where tropical rain forests are found in the world.
(3mks)

(b) State TWO factors favouring the development of soft wood forests in Kenya.
(2mks)

3. Explain how diamonds are processes. (5mks)

4. Outline the importance of oil exploitation in the Middle East countries.
(5mks)

5. Describe the characteristics of softwood forests in Canada.
(5mks)

SECTION B

ANSWER QUESTION 6 AND ANY OTHER TWO QUESTIONS IN THIS SECTION.

6. Study the data in the table below and answer the questions that follow.

Data showing items exported from countries A and B.

Country A		Country B	
Exports	Tonnes	Exports	Tonnes

FOR MARKING SCHEMES CALL/WHATSAPP 0746 222 000

Maize	12600	lubricating oil	2200
Coffee	9990	industrial chemicals	2100
Oil cakes	5560	fertilizers	5300
Spices	750	Vehicles	3300
		Wire products	2200
		Paper	2700
Total	28900	Total	17,800

(a) (i) Name the main export of each country.

(2mks)

(ii) Calculate the percentage of the export item with the least tonnage in each country.

(4mks)

(iii) Draw a divided rectangle 15cm long to represent the export items for country A.

(10mks)

(iv) State FIVE advantages of using divided rectangles to represent statistical data

(5mks)

(b) Differentiate between

(i) Primary data and secondary data

(2mks)

(ii) Discrete data and continuous data

(2mks)

7. (a) State FOUR ways in which minerals occur

(4mks)

(b) Name FIVE conditions necessary for the formation of petroleum

(5mks)

(c) Explain how the following factors influence mining.

(i) Capital

(2mks)

(ii) Value of the mineral.

(3mks)

(d) Describe how deep shaft mining is carried out.

(6mks)

(e) Give FIVE uses of Soda ash.

(5mks)

8. (a) Define the following terms;

(i) Forestry

(2mks)

(ii) Agro-forestry

(2mks)

(b) Explain how the following factors influence the distribution and types of natural forests.

(i) Climate

(4mks)

(ii) Altitude

(2mks)

(iii) Soils

(2mks)

(c) Explain FIVE reasons why tropical rain forests are difficult to exploit.

(10mks)

9. (a) Differentiate between human geography and economic geography.

(2mks)

FOR MARKING SCHEMES CALL/WHATSAPP 0746 222 000

- (b) Name at least FIVE human activities in Kenya. (5mks)
- (c) Your Geography class organized a field study on wildlife at Lake Nakuru National Park.
- (i) Apart from preparing a route map, identify other ways in which the class prepared for the study. (5mks)
- (ii) Why was it necessary to prepare a route map?
(4mks)
- (iii) Identify the activities the class was involved in during the study.
(6mks)
- (iv) Give THREE methods the class used to record data.
(3mks)

FORM 3 ENDTERM 2 EXAMS

AGRICULTURE

PAPER 1

TIME:2 HOURS

NAME..... ADM NO:.....

SIGN..... DATE;.....

- This paper contains three sections A, B and C.
- Answer all questions in Section A and B and any two from section C.
- All answers must be written in the spaces provided after the questions

SECTION A (30MKS)

1. Name any two physical characteristics used to classify soil. (2mks)

.....
.....
.....
.....

2. Name four types of livestock farming. (2mks)

.....
.....
.....
.....
.....

3. State four human factors that affect agriculture. (2mks)

.....
.....
.....
.....

.....
.....

4. What is the importance of seed dressing in crop production. (1mk)

.....
.....
.....
.....

5. State two conditions that may lead to sub-division of land. (2mks)

.....
.....
.....
.....

6. Farmer growing maize on 10 hectares is to dress it with sulphate of ammonia (20% N) at the rate of 120kg of S.A for hectare. AT the local market, S.A is available in 50Kg bag selling at 1500/- per bag. Calculate the amount of S.A the farmer needs to top dress his crop of maize. (3mks)

7. Define the following terms. (1½mks)

(i) Nursery bed

(ii) Seedling bed

(iii) Seedbed

8. State two examples of nitrogenous fertilizers. (2mks)

.....
.....
.....
.....

9. State three disadvantages of broadcasting seeds. (1¹/₂mks)

.....
.....
.....
.....
.....

10. State four deficiency symptoms of nitrogenous fertilizers. (2mks)

.....
.....
.....
.....
.....
.....

11. Give four conditions of the land which may make it necessary to carry out reclamation practices. (2mks)

12. State two mechanical methods of separating soil particles according to size during soil analysis. (2mks)

13. Give four pieces of information contained in a land title deed. (2mks)

.....
.....

.....
.....
.....
.....

14. State four effects of post election violence in 2008 to agriculture production. (2mks)

.....
.....
.....
.....
.....

15. State two reasons why shifting cultivation has become unpopular in Kenya. (1mk)

.....
.....
.....
.....

SECTION B

16. The diagram labeled E and F illustrate some soil structure. Study them carefully and answer the questions that follow.

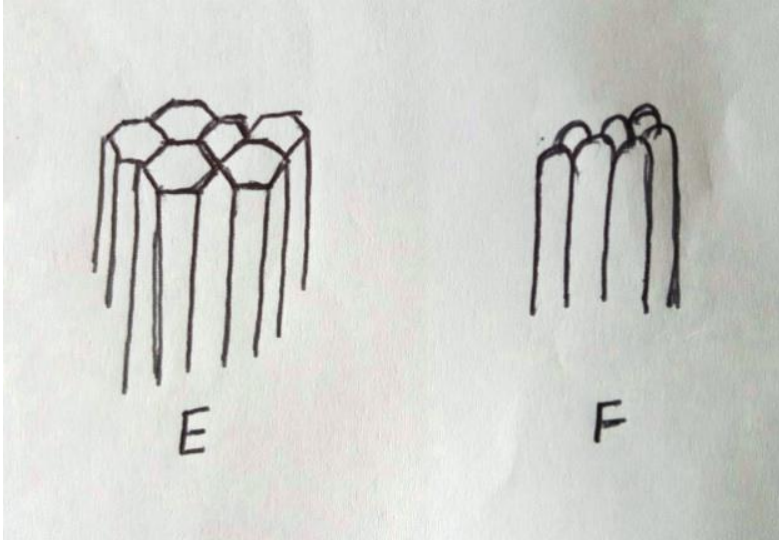

(i) Identify the soil structure E and F. (1mk)

.....
.....

.....
.....
(ii) List down two field practices which can destroys the structures shown above. (2mks)

.....
.....
.....
.....
(iii) Give two characteristic of a fertile soil. (2mks)

17. The diagram below illustrate a compose heap. Study it carefully.

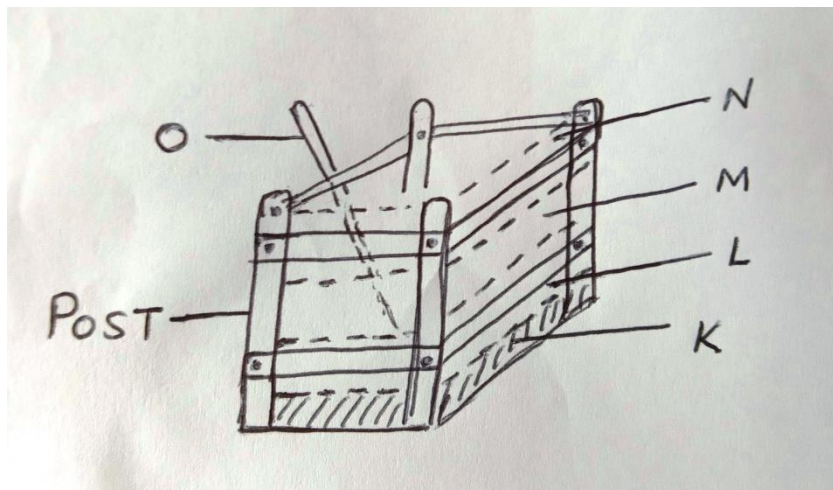

(a) Name the parts labeled K – N (2mks)

- K
- L
- M
- N

(b) State one use of each of the parts labeled K, M, N and O (2mks)

- K
- M
- N

O

(c) List four reasons why compost manure is not popularly used in the farm. (2mks)

18. Study the diagrams below.

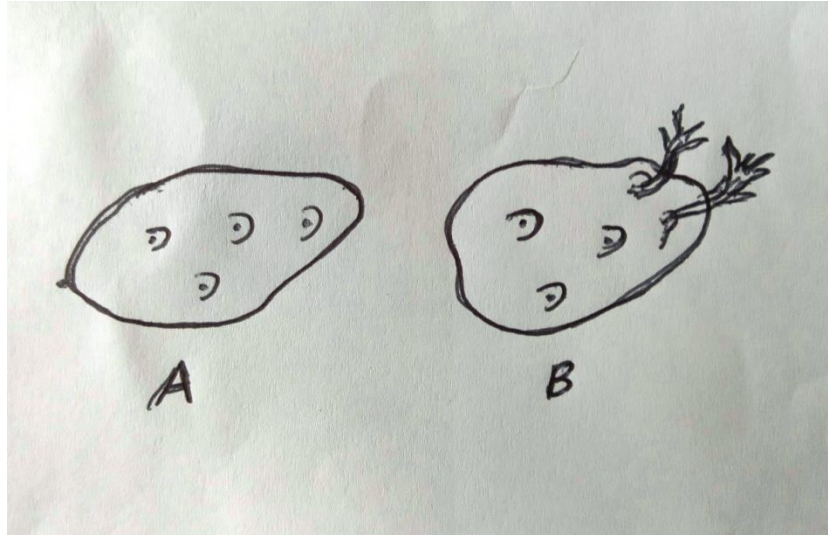

a) Name the process used to test Irish potatoes in readiness for planting. (1mk)

b) Which of the two is suitable for planting? (1mk)

c) Give a reason for your answer in (b) above. (1mk)

d) Give two reasons why maize need to be earthed. (2mks)

19.(a) State the two types of the multiple stem pruning system in coffee. (2mks)

(c) Name any two carrot varieties planted by farmers. (2mks)

SECTION C (40MKS)

- 20.**(a) Discuss the factors that should be put into consideration while choosing suitable implements for primary cultivation. (8mks)
- (b) Describe reasons for drainage as a method of land reclamation in crop production. (10mks)
- (c) State two factors that influence mass wasting (2mks)
-
- 21.**a) Discuss ways in which nitrogen is removed from the atmosphere. (8mks)
- b) Discuss factors to consider in choosing seed rates (10mks)
- c) State two main methods of planting (2mks)
-
- 22.**a) Mention the procedure involved in harvesting fish. (5mks)
- b) Discuss four types of soil erosion by water. (8mks)
- c) Mention various biological measures employed in soil and water conservation. (7mks)

FORM 3 ENDTERM 2 EXAMS

AGRICULTURE

PAPER 2

TIME:2 HOURS

NAME..... ADM NO:.....

SIGN..... DATE;.....

SECTION A (30 Marks)

Answer all questions in this section

1. Name **three** methods that are used in selection of breeding stock in livestock production.

.....
.....
.....
.....
.....
..... (1/2mks)

2. State **three** signs of heat in pigs. (1 1/2 mks)

.....
.....
.....
.....
.....

3. State **two** functions of a queen bee in a colony. (1mk).

.....
.....
.....
.....
.....

4. Name **two** breeds of sheep kept for dual purpose. (2mks)

.....

.....

.....

.....

5. Give any **four** advantages of artificial insemination. (2mks)

.....

.....

.....

.....

6. State **four** methods of identification in livestock. (2mks)

.....

.....

.....

.....

7. Give reasons why roughage is necessary in ruminant animals. (2mks)

.....

.....

.....

.....

8. What is a notifiable disease? (1/2mk)

.....

.....

9. State **four** qualities of livestock ration. (2mks)

.....

.....

.....

.....

10. Define the following terms. (2mks)

(i) Flushing

(ii) Crutching

(iii) Ringing

(iv) Raddling

11. A part from transmission of disease, give **three** harmful effects of ticks on cattle.

(1½mks)

.....
.....
.....
.....

12. State any **four** factors considered when siting farm structures (2mks)

.....
.....
.....
.....

13. State **four** major categories of farm tools and equipment (2mks)

.....
.....
.....
.....
.....

14. State **two** reasons for proper care and maintenance of farm tools and equipments (1mks)

.....
.....
.....

.....
.....
15. Give the functional difference between a rip saw and a cross cut saw. (1mk)

.....
.....
.....
.....

16. Differentiate between a broiler and a capon (1mk)

.....
.....
.....
.....

17. State **two** advantages of using embryo transplant. (1mks)

.....
.....
.....
.....
.....

18. Give **four** reasons for seasoning timber before use. (2 marks)

.....
.....
.....
.....

19. State any **four** reasons for castrating a goat. (2mks)

.....
.....
.....
.....

SECTION B (20 marks)

Answer all questions in this section

20. If the maize meal contains 6% Digestible Crude Protein (DCP) and Fish meal contains 64% DCP, calculate the amount of each feed stuff in kilograms, required to Prepare 200kg of chick mash containing 18% DCP (Show your working) (4mks)

21. Study the farm tools below and answer the questions that follow

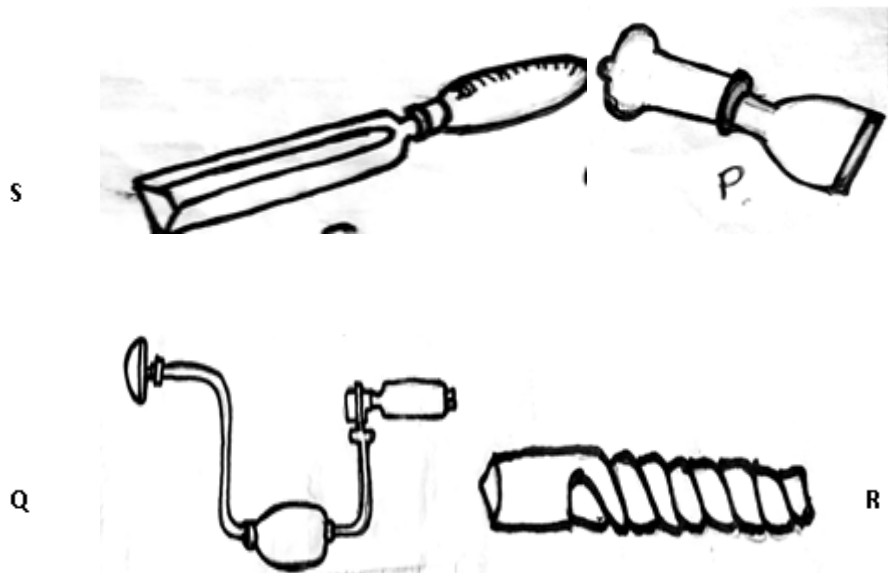

- (a) Identify the farm tools labeled S, P, Q and R (2mks)

S

P

Q

R

- (b) State the use of each of the tools labeled S and P

(1mk)

S

P

(c) Give **two** safety precaution that should be taken when using the pair of tools Q and R above (1mk)

(d) State **two** maintenance practices which should be carried out on the tool Q (1mk)

.....
.....
.....

22. The diagram below shows parts of a plunge dip.

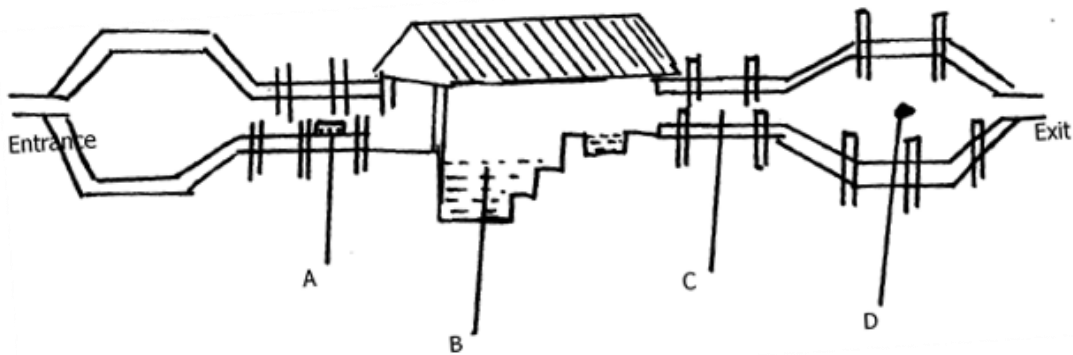

i) Name parts A, B, C and D (2mks)

- A
- B
- C
- D

ii) Give **two** reasons why cattle are held for some time in part C. (2mks)

.....
.....
.....
.....
.....

iii) State **two** maintenance practices carried out on part B. (2mks)

.....
.....
.....
.....

23. Study the illustration of a camel below and answer the questions that follow

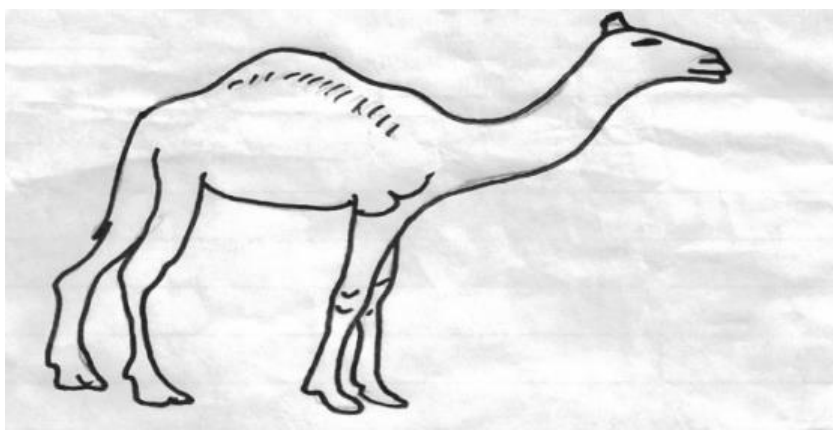

f) Name the species of camel shown above (1mk)

.....
.....
.....

(b) Name the environmental condition under which the camel above survives better (1mk)

.....
.....
.....

(c) Give **two** reasons which make it possible for the livestock to survive in such environment (2mks)

.....
.....
.....

(d) Name another species of camel other than the one above (1mk)

.....
.....
.....

SECTION C (40MARKS)

Answer any two questions

- 24 (a) Explain factors to consider during selection of a breeding stock. (10mks)
(b) Give reasons for maintaining a healthy stock on the farm (10mks)
- 25 (a) Explain **ten** effects of strong wind on crop production. (10mks)
(b) Describe **ten** cultural or biological methods of controlling soil erosion. (10mks)
- 26 a) Draw the differences between the digestive system of a ruminant and a non-ruminant
(5mks)
- (b) Explain **five** functions of water in nutrition (5mks)
- (c) State **ten** safety precautions which should be taken when using
Workshop tools in order to prevent injury (10mks)

FORM 3 ENDTERM 2 EXAMS

BUSINESS STUDIES

PAPER 1

TIME:2 HOURS

NAME..... ADM NO:.....

SIGN..... DATE;.....

INSTURCTIONS TO CANDIDATES

- a) Write your name and adm. no in the spaces provided above.
- b) Sign and write the date of examination in the spaces provided above.
- c) Answer ALL the questions.
- d) All answers should be written in the spaces provided in this booklet.
- e) This paper consists of 8 printed pages
- f) Candidates should check the question paper to ascertain that all the pages are printed as indicated and that no questions are missing.
- g) Candidates should answer all the questions in English

FOR EXAMINER'S USE ONLY

Question	1	2	3	4	5	6	7	8	9	10	11	12	13	14
Candidate's score														

Question	15	16	17	18	19	20	21	22	23	24	25
----------	----	----	----	----	----	----	----	----	----	----	----

FOR MARKING SCHEMES CALL/WHATSAPP 0746 222 000

Candidate's score											
-------------------	--	--	--	--	--	--	--	--	--	--	--

TOTAL MARKS

1. Define the following terms as used in Business Studies. (4 mks)

- (i) Economics.....
.....
- (ii) Entrepreneurship.....
.....
- (iii) Opportunity cost.....
.....
- (iv) Scale of preference.....
.....

2. Highlight four features of a good filling system. (4 mks)

- (i)
- (ii)
- (iii)
- (iv)

3. Outline four importance of a warehouse to a consumer. (4 mks)

- (i)
- (ii)
- (iii)
- (iv)

4. Outline four benefits of a business plan. (4 mks)

- (i)
- (ii)
- (iii)
- (iv)

5. Highlight four functions of an entrepreneur.(4mks)

- (i)
- (ii)
- (iii)
- (iv)

6. State four importance of a balance sheet (4 mks)

- (i)
- (ii)
- (iii)
- (iv)

7. The following information was extracted from the books of Dawida businesses enterprise for the year ended 30th June 2000.

Capital as at 30 th June, 2000	640,000
Capital as at 1 st July 1999	420,000
Drawing for the year	180,000
Net profit for the year	140,000

Determine the additional capital during the year. (5 mks)

8. Highlight four barriers to effective communication (4 mks)

- (i)
- (ii)
- (iii)
- (iv)

9. Below is a demand and supply curve.

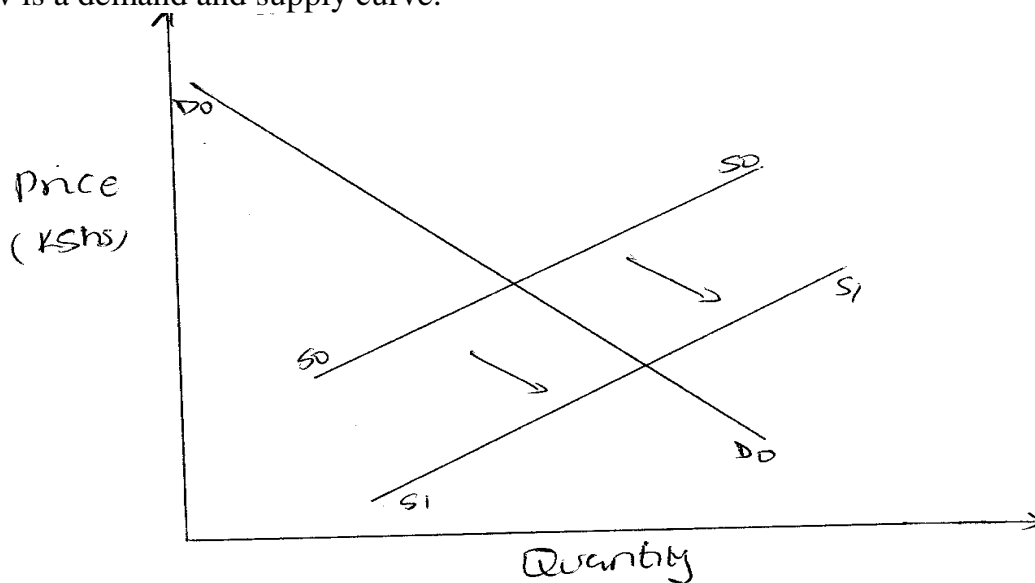

Highlight the factors that may have led to the above behavior. (4 mks)

- (i)
- (ii)
- (iii)
- (iv)

10. Outline four circumstances under which a cheque maybe be dishonoured. (4 mks)

- (i)
- (ii)
- (iii)
- (iv)

11. Give the difference between:

(4 mks)

(a) Double and co-insurance

.....
.....
.....

(b) Premiums and surrender value

.....
.....
.....

12. Highlight four advantages of indirect production (4 mks)

- (i)
- (ii)
- (iii)
- (iv)

13. Highlight four methods through which the government get involved in business activities.

(4 mks)

- (i)
- (ii)
- (iii)
- (iv)

14. Highlight four duties of commercial attaches in trade promotion.

(4 mks)

- (i)
- (ii)
- (iii)
- (iv)

15. Complete the table below. (4 mks)

FACTOR OF PRODUCTION	REWARD
Land	
Capital	
Labour	
Entrepreneurship	

16. Outline three leakages in a circular flow of income. (3 mks)

- (i)
- (ii)
- (iii)

17. Outline four advantages of using celebrities in product promotion. (4 mks)

- (i)
- (ii)
- (iii)
- (iv)

18. Distinguish between goods and services. (4 mks)

GOODS	SERVICES

19. Kenya is planning to extend her pipeline transport. State four advantages of pipeline transport to the country. (4 mks)

- (i)
- (ii)
- (iii)
- (iv)

20. Outline four factors that determine the size of a firm. (4 mks)

- (i)
- (ii)
- (iii)
- (iv)

21. Kiburu carried out the following transactions during the month of February 2015.

- February 1: Started business by depositing sh 220,000 in business bank account
- 7: Bought goods on credit from Miyogo Sh 72,000
- 8: Paid rent by cheque Sh 20,000
- 16: Sold goods to Kamula on credit Sh 50,000.

Required: Post the above transaction in the relevant ledge accounts. (8mks)

22. Highlight four features of perfect competition market.

(4 mks)

- (i)
- (ii)
- (iii)
- (iv)

23. Mention whether the following transactions have an increase, decrease or no effect on the assts, capital and liabilities of a business. (4 mks)

	Transaction	Assets	Capital	Liabilities
(a)	Bought premises on credit			
(b)	Took stock of goods and donated to a local dispensary			
(c)	Withdrew money from bank for office use			
(d)	Sold furniture receiving cash			

24. State the following abbreviations in full

(4mks)

- (i) GDP.....
- (ii) GNP.....
- (iii) NDP.....
- (iv) NNP.....

FORM 3 ENDTERM 2 EXAMS

BUSINESS STUDIES

PAPER 2

TIME:2 ½ HOURS

NAME..... ADM NO:.....

SIGN..... DATE;.....

INSTRUCTIONS:

Attempt any five questions from this paper.

1. a) Discuss five factors that may influence entrepreneurial practice positively in the country. (10mks)
b) Explain five principals of insurance. (10mks)

2. a) Explain five benefits of matatu reforms in transport sector.(10mks)
b) Using a well labeled diagram, differentiate between shift in demand curve and movement along the demand curve. (10mks)

3. a) Muema is planning to construct a warehouse for renting. Explain five measures that he may take to ensure its smooth operation. (10mks)
b) Explain five methods used to distribute imported manufactured goods. (10mks)

4. a) Outline five measures that the Kenya government may take to reduce unemployment. (10mks)
b) Explain five measures that the government may take to increase supply of maize in the market. (10mks)

5. a) Describe any five types of business activities. (10mks)
b) Munguti, who runs a retail store, had the following assets and liabilities as at 31st March 2016.

Premises	Sh. 100,000
Debtors	Sh. 4,000
Creditors	Sh. 16,000
Stock	Sh. 2,000
Cash at bank	Sh. 60,000
Cash in hand	Sh. 20,000
Loan from AFC	Sh. 50,000

During the month of April 2015, the following transactions took place
2015

April 1st sold goods at cost Sh. 2000 cash

April 2nd Paid creditors Sh. 8000 cash

April 10th received Sh. 2000 from his debtors in cash

April 15th Bought a motor van for Sh. 35,00 paying by cheque

April 25th purchased goods worth Sh. 15000 and paid by cheque

Required: Prepare a balance sheet as at 25th April 2015. (10mks)

6. a) Describe the following terms as used in accounting.

i) Assets (2mks)

ii) Credit transactions. (2mks)

iii) Networth of a Business. (2mks)

iv) Ledger. (2mks)

b) Muinamo started a business on 1st March 2012 with a capital of 240,000 consisting of Sh. 130,00 in bank, Sh. 50,000 in cash and furniture worth Sh. 60,00. Transactions for the first week were as follows;

2012: March 2nd purchased a typewriter by cheque Sh. 20,000

March 3rd bought delivery van for Sh. 450,000 from Mwangaza motors on Credit

March 4th Bought stock worth Sh. 15,000 for cash

March 5th Purchased goods worth Sh. 18,000 from Kinyua on credit

March 6th sold goods worth Sh. 30,000 on credit to Menge

March 7th paid 12,000 to Kinyua by Cheque

March 7th received Sh. 4,000 for rent by cheque

Required: Record the above information in the relevant ledger accounts and balance them off on 7th March 2012. (10mks)

FOR MARKING SCHEMES

CONTACT 0746 222 000

FOR MARKING SCHEMES CALL/WHATSAPP 0746 222 000