

AGRICULTURE NOTES

FORM 1 SIMPLIFIED VERSION

QUICK REVISION GUIDE

*An Updated Well-Organized Detailed Revision Notes for the
Current Form 1 Syllabus.*

**A Comprehensive Summary Analysis of
Agriculture KLB Work.**

SERIES 1

Past KCSE Topical Questions Available At The End Of This Book.

Mr Isaboke 0746 222 000

MWALIMU CONSULTANCY

Copyright ©Mwalimu

All rights reserved. This book or any portion thereof may not be reproduced or used in any manner whatsoever without the express written permission of the publisher except for the use of brief quotations in a book review.

Printed in Kenya

00100

Nairobi

0746-222-000

mwalimuconsultancy@gmail.com

Mwalimu Consultancy Ltd.

TABLE OF CONTENTS

1.0.0 Introduction to Agriculture (8 Lessons)

2.0.0 Factors Influencing Agriculture (24 Lessons)

3.0.0. Farm Tools And Equipment (7 Lessons)

4.0.0 Crop Production I (Land Preparation) (7 Lessons)

5.0.0 Water Supply, Irrigation And Drainage (10 Lessons)

6.0.0 Soil Fertility I (Organic Manures) (6 Lessons)

7.0.0 Livestock Production I (Common Breeds) (7 Lessons)

8.0.0 Agricultural Economics I (Basic Concepts and Farm Records) (7 Lessons)

INTRODUCTION TO AGRICULTURE

Definition of Agriculture

- Agriculture is the science and art of cultivation of crops and rearing of livestock.
- **As a science**, it involves *experimentation* and *application of scientific knowledge* in such areas as;
 - Soil analysis,
 - Control of pests and diseases,
 - Farm machinery and structures,
 - Crop and livestock breeding.
- **As an art, it involves the use of learned skills in;**
 - Tilling the land,
 - Construction,
 - Measurement,
 - Harvesting of crops,
 - Feeding and handling of livestock
 - Marketing.

Branches of Agriculture

Crop Farming (Arable Farming)

- The practice of growing crops on cultivated land.

It is subdivided into:

- ***Field crops Cultivation:***
 - maize, beans, potatoes, coffee, tea, cotton to name but a few.
- ***Horticulture:***
 - It involves the growing of perishable crops which have high value.
 - It is further subdivided into:
 - ***Floriculture*** - the growing of flowers.
 - ***Olericulture*** - the growing of vegetables.
 - ***Pomoculture*** - the growing of fruits.

Livestock Farming

- This branch deals with the rearing of livestock for various products.

It is further subdivided into:

- *Pastoralism*: This is the rearing of mammalian livestock such as cattle, sheep, goats, rabbits, pigs and camels.
- *Fish Farming (Aquaculture)*: This is the practice of rearing fish and other aquatic organisms , in ponds.
- *Bee Keeping (Apiculture)*: This involves the rearing of bees in structures known as beehives.
- *Poultry Keeping*: This is the keeping of domesticated birds.

Agricultural Economics

- It deals with the allocation of scarce resources (land, labour, capital and management) for agricultural production.

Agricultural Engineering

- This branch of agriculture deals with the use and maintenance of farm tools, machinery and structures.

Farming Systems

- A farming system is the organization of the various enterprises in a farm.

It is determined by the following factors:

- Resources available (land, labour, capital and management).
- Skills of the farmer.
- Environmental factors such as climate, soil type and topography.
- Government policy.
- Farmer's choice and preference.
- Enterprise requirement.
- Social-cultural factors.

The following are systems of farming:

Extensive System:

- It is a system where a large piece of land with low investment of resources per unit area is carried out.

Advantages

- It is cheap.
- Does not require high level of management.
- Requires less labour.

Disadvantages

- Low profit per unit area.
- Cannot be practiced where land is limited.
- Low output per unit area.
- The land is under-utilized,
-

Intensive Farming:

- This system utilizes the factors of production to the maximum and involves high level of management.

Advantages

- Maximum utilization of the resources.
- Can be practiced even where land is a limiting factor.
- Results in high yields.

Disadvantages

- Labour intensive.
- High capital investment is required.
- Requires high level of management.
- Can lead to high losses in case of poor management.

Large Scale Farming

- Refers to the farming practice under large areas of land over 20 hectares.
- It is used mainly for commercial purposes.
- The system is highly mechanized.

Advantages

- Results in high yields.
- Due to economics of scale high profit is realized.

Disadvantages

- Lack of diversification may lead to total failure in case of unfavorable conditions.
- High level of management is required.
- Heavy capital investment.
- Requires skilled and qualified manpower.

Small Scale Farming

- Refers to farming carried out on a small area of land less than 5 hectares.
- Family or casual labour can be engaged during the peak periods.
- Most of the Kenyan farmers are small scale due to unavailability of farmland.

Advantages

- Requires low capital investment.
- Possible where land is a limiting factor.
- Does not require high management level unless under intensive system.

Disadvantages

- Uneconomical to mechanize due to small size.
- Low production.
- Provides limited employment.
- Labour intensive.
- Difficult to specialize.

Methods of Farming

- A method of farming is an established way of carrying out farming activities.
- The following are the common methods of farming:

Mixed Farming

- It is the practice of growing crops and keeping of livestock on the same land.
- Its common in high potential areas.

Advantages

- Mutual benefit between crops and livestock.
- Crops supply feed for animals while animals supply manure for crops.
- Acts as an insurance against total loss by the farmer.
- The farmer is assured of an income throughout the year.
- There is maximum utilization of the resources.
- Animals can be used in the farm activities particularly draught animals.
- Ensures proper utilization of labour and land throughout the year.

Disadvantages

- High initial capital.
- Lack of specialization.
- Land can be a limiting factor if both enterprises are to be raised.
- Requires high level of management for both enterprises.

Nomadic-Pastoralism

- This is the practice of livestock rearing whereby animals are moved from one place to another in search of water and pastures.
- It is practiced in the arid and semi-arid areas where in most cases beef animals are kept.

Nomadic pastoralism is gradually changing to ranching with the introduction of:

- Improved pasture species, improved livestock breeds and supplementary feeding.
- Efficient disease and parasite control measures.
- Improved infra-structure such as roads, water supply, cattle dipping facilities.
- Extension services.

Advantages

- Serves as the backbone of beef industry in Kenya.
- Proper way of utilizing the arid and semi arid areas.
- Source of income to the pastoral communities.

Disadvantages

- It encourages the spread of livestock pests and diseases due to communal watering points, grazing and dipping facilities.
- There is a tendency to increased soil erosion and land degradation.
- Source of conflicts and ethnic tension among the nomadic communities for the control of good pastures and water.
- Difficult to control breeding and breeding diseases.
- High rate of inbreeding leading to poor quality livestock.
- Low production of milk, meat, hides and skins due to wastage of energy in traveling from one place to another in search of pastures and water.
- High death rates as a result of walking for long distances.

Shifting Cultivation

- It is a traditional method of cultivating a piece of land until the soil is exhausted and crop yields decline.
- The land is abandoned and the farmer shifts to a new field as the previous land is left fallow to regain its fertility.

Advantages

- Land is allowed to rest and regain its fertility.
- No build up of pests and diseases.
- Soil structure is restored.
- The cost of production is low since inorganic fertilizers and pesticides are not used.
- Crop produce are chemical free.

Disadvantages

- Not practical where land is a limiting factor.
- Farm planning and acquisition of credits for land development is 'not possible.
- It is a cumbersome method due to constant movement.
- Lack of soil conservation measures
- Not possible to grow perennial crops.
- Low output per unit area due to poor farming methods.
- Where fire is used to clear the land organic matter is destroyed.

Organic Farming

- It is a farming method where crops are grown and livestock reared without the use of agro-chemicals.
- It is a method of farming which has been adopted to reduce the long term effect of the agro-chemicals on crops which may eventually end up in man and livestock.
- Agro-chemicals are also expensive thus organic farming reduces the cost of production. Organically produced goods fetch high market prices.

Advantages

- Cheap and cost effective.
- Make use of the locally available materials
- Useful in improving the soil structures.
- No side effects from the crops and livestock products.
- No environmental pollution.

Agro-Forestry

- This is the practice of integrating trees and crops on the same piece of land.
- With land resources becoming more scarce, agroforestry is becoming more important.

Examples of common agroforestry trees and shrubs include:

- *Cajanus cajan*
- *Grevillea robusta*
- *Sesbania sesban*
- *Calliandra calothyrsus*
- *Casuarina equisetifolia*
- *Leucaena leucocephala*

Trees selected for agroforestry should have the following characteristics:

- Able to grow fast.
- Deep roots to minimize competition for nutrients.
- Should be preferably leguminous.

Advantages

- Trees reduce soil erosion in a given area.
- Leguminous trees add nitrates into the soil thus improving the *soil* fertility.
- Some trees can be used as livestock fodder to provide a high level of proteins.
- They are important sources of wood fuel and timber.
- There is maximum utilization of land.

Importance of Agriculture to the Economy of Kenya

- Provides *food* to the population to meet nutritional requirements and to enable man to engage in other activities of farming.
- Provides *employment*. This for example can be direct as a labourer in the farm, tea plucker or indirect for example, working in agricultural based industries.
- Source of *raw materials* for industries for example cotton lint for textile industry.
- Provides *foreign exchange* - through exporting agricultural produce.
- Provides *market for industrial goods* agriculture is a consumer of the finished goods from agro-based industries.
- Source of *income* - farmers as well as the government get revenue from the sale of agricultural produce and tax payment.

***This is a Property of Mwalimu Consultancy Ltd. Contact Mr Isaboke
0746-222-000 for more Educational Materials.***

FACTORS INFLUENCING AGRICULTURE

Introduction

Agricultural production is influenced by external factors:

- Human factors
- Biotic factors
- Climatic factors
- Edaphic factors.

Human Factors

These are human characteristics which affect the way decisions are made and operations carried out.

- ***Level of education and technology:***
 - Skills
 - Technological ad van cements .
- ***Human health/HIV-AIDS:***
 - These affect the strength, the vigour, vision and the determination to work.
 - HIV/AIDS is the biggest threat to human health today and has long lasting effects on agriculture, such as;
 - Shortage of farm labour.
 - Loss of family support.
 - Low living standards leading to despondency and hopelessness.
 - Increased criminal activities.
 - More time spent by the Government and NGO's in Carring for the sick.
- ***Economy;***
 - Stability in the countries' economy affect agricultural production.
- **Government Policy:**
 - These are governmental laws which have been enacted to protect farmers, land and livestock.

They include:

- Food policy
- Policies on control of livestock parasites and diseases.
- Policies on marketing of both local and export products and others.
- **Transport and communication:**
 - For agricultural goods to move from the farm to the consumers.
- **Cultural practices and religious beliefs:**
 - These activities hinder important changes in a society that may bring agricultural development.
- **Market forces:**
 - Demand and supply forces which affect prices of commodities in a free market.

Biotic Factors

These are living organisms which affect agricultural production.

- **Pests** - Destructive organisms which destroy crops.
- **Parasites** - These are invertebrates which live in or on other living organisms.
- **Decomposers** - Organisms which act on plants and animal tissues to form manure.
- **Pathogens** - Micro-organisms which cause diseases.
- **Predators** - Animals that kill and feed on other animals.
- **Pollinators** - They transfer pollen grains from the stamens to the pistil of a flower.
- **Nitrogen fixing bacteria** - They are micro-organisms which convert atmospheric nitrogen to nitrates ready for use by the plants.

Climatic Factors(weather elements).

- Rainfall,
- Temperature,
- Wind,
- Relative humidity
- Light.

Weather - Atmospheric conditions of a place at a given time period.

Climate - weather conditions of a place observed and recorded for a period of 30-40 years.

Rainfall

Supplies Water:

- Which is necessary for the life process in plants and animals.
- Which makes the plant turgid hence provides support.
- Acts as a solvent for plant nutrients.
- Cools the plant during transpiration.
- Which is used as a raw material in photosynthesis.

When plants lack enough water they respond in different ways as follows:

- By closing the stomata to restrict water loss.
- Hastens maturity.
- Some will roll their leaves.

Other plants have developed permanent adaptation to water stress such as:

- Growing needle like leaves.
- Develop fleshy leaves for water storage.
- Develop long roots.
- Wilting and death in extreme conditions.

Important Aspects of Rainfall:

- ***Rainfall reliability;***
 - This is the dependency on the timing of the onset of the rains.
- ***Amount of rainfall;***
 - Quantity of rain that falls in a given area within a given year.
- ***Rainfall distribution ;***
 - The number of wet months in a year.
- ***Rainfall intensity;***
 - Amount of rainfall that falls in an area within a period of 1 hour.

Temperature

- This is the degree of hotness or coldness of a place measured in degrees Celsius.
- ***Cardinal range*** of temperature is the temperature required by plant to grow and thrive well.
- ***Optimum range of temperatures*** - the best temperature for the best performance of plants.

Effects of Temperatures on Crop Production:

Low temperatures:

- Slow the growth rate of crops due to slowed photosynthesis and respiration.
- High incidences of disease infection.
- Improves quality of crops such as tea and pyrethrum.

High Temperatures

- Increase evaporation rate leading to
- Wilting.
- Hastens the maturity of crops.
- Increase disease and pest infection.
- Improves quality of crops such as pineapples, oranges and pawpaws.

Wind

Wind is moving air.

Good effects of wind include:

- Seed dispersal
- Cooling of land
- Pollination in crops
- Brings rain bearing clouds

Negative effects of wind:

- Increases the rate of evaporation of water.
- Causes lodging of cereals and distorts perennial crops.
- Increases evapo-transpiration.
- Spreads diseases and pests.
- Destroys farm structures.

Relative humidity

- The amount of water vapour in the air
- Affects the rate of evapo-transpiration.
- Forms dew which supplies soil with moisture under dry conditions.
- High humidity induce rooting in cuttings.
- Increases disease multiplication and spread.

Light

- Provide radiant energy harnessed by green plant for photosynthesis.

Important aspects of light:

- ***Light intensity ;***
 - The strength with which light is harnessed by chlorophyll for photosynthesis.
- ***Light duration;***
 - The period during which light is available to plants per day.
 - Plant response to light duration is known as ***photoperiodism***.
 - ***Short-day plants*** - require less than 12 hours of daylight to flower and seed.
 - ***Long-day plants*** - require more than 12 hours of daylight to flower and seed.
 - ***Day-neutral plants*** require 12 hours of daylight to flower and seed.
- ***Light wavelength;***
 - This is the distance between two - successive crests of a wavelength.
 - It dictates the difference between natural and artificial light.
 - Chlorophyll absorbs certain wavelengths of light.

Edaphic Factors Influencing Agriculture

- These are soil factors.
- Soil is the natural material that covers the surface of the earth,
- Made of weathered rock particles and decomposed animal and plant tissues, and on which plants grow.

Importance of Soil

- Provides anchorage to the plants by holding their roots firmly.
- Provides plants with mineral salts/ nutrients which are necessary for their growth.
- Provide the plants with water.
- Contains oxygen necessary for respiration of the plants and soil micro-organisms.

Soil Formation:

- Soil is formed through weathering process.
- Weathering is the breakdown and alteration of the parent rock near the surface of the earth to a stable substance.

- Weathering process is a combination of disintegration (breakdown) and synthesis (build up) process.
- Weathering process is continuous.

Types of Weathering

- Physical weathering
- Chemical weathering
- Biological weathering

Agents of Weathering

Physical Agents of Weathering

- Include wind, water, moving ice and temperature.
- **Wind** - carry materials which hit against each other to break into fragments.
- **Water** - intensity of rainfall causes breakdown of rock.
- **Moving ice** - has grinding effects which tear off rock particles.
- **Extreme temperature** cause rocks to expand and contract suddenly peeling off their surface.

Chemical Weathering

- Affects the chemical composition and structure of the rock.
- Involves processes such as ;
 - Hydrolysis,
 - Hydration,
 - Carbonation
 - Oxidation.
- **Hydration;**
 - The process by which soluble minerals in the rocks absorb water and expand weakening the rock thus leading to disintegration.
- **Hydrolysis;**
 - The process whereby water dissolves soluble minerals in the rock weakening it.
- **Oxidation;**
 - The reaction of rock minerals with oxygen to form oxides which break easily.

- **Carbonation;**
 - The process whereby carbonic acids formed when rain water dissolves carbon dioxide,
 - It reacts with calcium carbonates in limestone causing it to disintegrate.
 -

Biological Weathering

This involves the action of living organisms, plants and animals on the rocks.

- **Burrowing animals**, for example, termites and moles bring soil particles to the surface exposing them to other agents of weathering.
- **Big animals** like, elephants, buffaloes, camels and cattle exert a lot of pressure on the rocks as they step on them due to their heavy weights causing the rocks to disintegrate.
- **Earthworms** take part in the decomposition of plant matter with the soil particles.
- **Man's activities** like, mining and quarrying expose rocks to the surface during excavation. These activities breakdown large rocks into smaller rock particles.
- **Plant roots** force their way through the cracks in the rocks thus widening and splitting them.
- **Humic acids** formed when plant tissues decompose react with the rocks weakening them further.
- **Plant remains**-decompose adding humus into the soil.

Factors influencing soil formation

- **Climate**- (rainfall, temperature and wind)
- **Biotic factors** - living organisms.
- **Parent material**- Nature and properties of the original rock from which the soil is formed.
- **Time** - length of time during which the soil forming processes have taken place.
- **Topography** - influences the movement of disintegrated materials.

Soil Profile

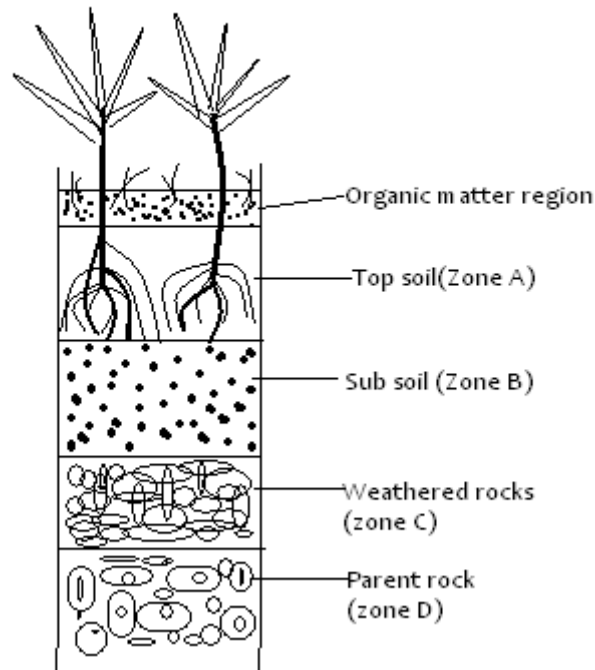

- It is the vertical arrangement of different layers of soil from the ground surface to the bedrock.
- These layers are also referred to as *horizons*.
- The layers show differences in their contents and physical properties such as colour, texture and structure.
- The layers include: organic matter region, top soil, sub-soil, weathered rocks and parent material.

Organic Matter Region

- First layer of the soil found on the surface.
- Made up of leaves and other plant remains at various stages of decomposition.
- Some soil organisms may also be found here.

Top Soil

- Has a dark colour due to the presence of humus.
- Is rich in plant nutrients and well aerated.
- It is a zone of maximum leaching (zone of eluviations)

Sub-Soil

- It is compact and less aerated.
- It is a zone of accumulation of leached material (zone of aluviation) from the top layers.
- Deep rooted crops have their roots growing up to this region.
- Hard pans normally form in this layer

Weathered Rocks

- It is also called substratum.
- Rocks at various stages of disintegration are found in this zone.
- Most of the materials found in this zone originate from the parent rock.

Parent Rock

- It exists as a solid mass which is un-weathered.
- It is the source of the inorganic composition of the soil.
- The water table is on the surface of this rock.

Soils Formed in Situ and Soils Deposited

- Soil formed in the same place and remains there is said to be *in situ*.
- However, soil can be formed due to deposition of soil particles carried from its original site of formation to another area which is usually in the lower areas of slopes.
- Such soils are said to have been formed through deposition.

<i>Soil Formed in Situ</i>	<i>Soil Deposited</i>
1.Has the colour of the parent	1. Has the characteristics of when: it
2. Shallower	2. Deeper
3. Less rich in plant nutrients	3. Richer in plant nutrients
4. Easily eroded	4. Not easily eroded
5. Less silty	5. More silty
6. Have the same chemical	6. Differ in chemical composition from
as that of the underlying	underlying parent
parent rock	rock

Soil Depth

- This is the distance between top soil layer and the bottom soil layer in a profile.
- It dictates root penetration and growth
- Deep soils are more suitable for crop growth since they contain more nutrients.
- Have a larger surface area for root expansion.
- Deep soils facilitate good drainage and aeration.

Soil Constituents

- ***Organic Matter*** - Dead and decaying plants and animal remains
- ***Living Organisms*** - Soil organisms and plant roots.
 - Micro-organisms (bacteria, protozoa and fungi)
 - Invertebrates -termites,
 - Earthworms and mollusks.
 - Higher animals - rodents and others.
- ***Inorganic or Mineral Matter***
 - Formed from the parent materials.
 - Supply plant nutrients
 - Form the skeleton and framework of the soil.
- ***Air***
 - Found in the pore spaces of the soil.
 - Used for root and organism respiration
 - Used for germination of seeds.
 - Helps in decomposition of organic matter.
 - Regulates soil temperature.
 - Regulates the movement of water through capillary action.
- ***Water***
 - Dissolves mineral salts
 - Maintain turgidity in plants.
 - Used for germination of seeds
 - Used by soil organisms.
 - Regulate soil temperature
 - Dictates the amount of air in the soil.

Water in the soil exists in three forms namely:

- ***Superfluous/Gravitational Water***
 - Found in the large spaces (macro-pores) in the soil particles.
 - Held by gravitation forces.
 - When the pores are saturated, the soil is said to be waterlogged.
 - It moves and may cause leaching.

- ***Hygroscopic Water***
 - Water found in thin films on the soil particles.
 - Held by strong adhesive forces between water and soil particles.
 - Does not move and hence not available for plant use.

- ***Capillary Water***
 - Occupy micro-pores in the soil particles.
 - Held by cohesive forces between water molecules.
 - Moves through capillary action
 - Available to plants for use.

Soil Structure

- This is the arrangement of soil particles in a soil horizon.
- ***Types of Soil Structure –***
 - Single-grained
 - Crumby
 - Granular
 - Prismatic
 - Columnar
 - Platy
 - Blocky

soil structure

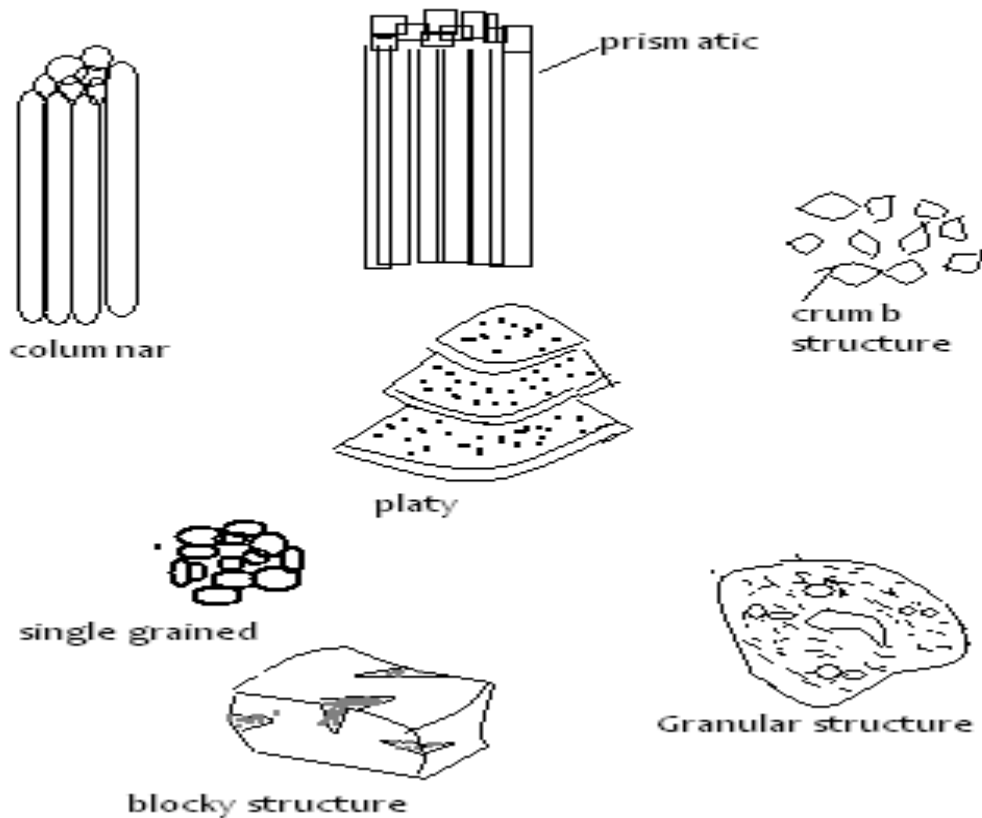

Importance of Soil Structure on Crop Production

Soil Structure Influences

- Soil aeration
- Soil drainage and water holding capacity.
- Plants root penetrability and anchorage.
- Microbial activities in the soil.
- Circulation of gases in the soil.

Farming practices which improve the soil structure are:

- Application of inorganic manure into the soil.
- Tilling the land at the right moisture content.
- Crop rotation.
- Minimum tillage.
- Cover cropping.
- Mulching.

Soil Texture

- It refers to the relative proportion of the various sizes of the mineral particles of soil.

Importance of Soil Texture on Crop Production;

- Influences soil fertility
- Affects the organic matter content
- Influences the drainage of the soil.
- Influences soil aeration.
- Influences water holding capacity.
- Influences the capillarity or movement of water in the soil.

Soil Textural Classes

Sandy Soils

- Made up largely of sand particles.
- Have large pore spaces hence poor in water retention.
- Easy to till (light soils).
- Freely draining.
- Low fertility due to leaching of minerals.
- Easily erodible.

Clayey Soils

- Made up largely of clayey particles.
- Have small pore spaces hence good in moisture retention.
- Difficult to till (heavy soils).
- Poorly 'drained.
- Expand when wet, crack when dry.
- High capillary.
- Rich in plant nutrients.

Loam Soils

- About equal amounts of sand and clay.
- Moderately good in both moisture and air retention.
- Fertile soils.

Soil Colour

- This depends on the, mineral composition of the parent rock and the organic matter content.
- Soils containing a lot of iron are brownish, yellowing and reddish in colour.
- Soils with a lot of silica are white.
- Soils with a lot of humus are dark or grey.

Soil pH

- This refers to the acidity or alkalinity of the soil solution/the concentration of hydrogen ions in the soil solution.
- Soil pH is determined by the concentration of hydrogen ions (H⁺) or the hydroxyl ions (OH⁻) in the soil solution.
- A pH of less than 7 means that the soil is acidic.
- A pH of more than 7 means that the soil is alkaline.
- As the hydroxyl ions (OH⁻) in the soil increase the soil becomes more alkaline.

Influence of Soil pH Crop Growth

- It determines the type of crop to be grown in a particular area.
- Most crops are affected by either very acidic or very basic soil pH.
- Soil pH affects the choice of fertilizers and the availability of nutrients to crops.
- At low pH the concentration of available iron and aluminium in the soil solution may increase to toxic levels, which is harmful to plants.
- Very acidic or low pH inhibit the activity of soil micro-organisms.

***This is a Property of Mwalimu Consultancy Ltd. Contact Mr Isaboke 0746-222-000
for more Educational Materials.***

FARM TOOLS AND EQUIPMENT

Introduction

- Farm tools and equipment perform specific jobs in the farm.
- They make work easier and more efficient.
- They can be classified according to their uses as follows:

Garden Tools and Equipment

Tools	Uses
Panga	Cutting and shallow cultivation, making holes.
Jembe/hand hoe	Cultivation, digging, shallow planting holes and trenches.
Fork jembe	Cultivation, digging out roots, harvesting of root crops.
Rake	Collecting trash, breaking large clods, levelling, removing stones from a seedbed and spreading organic manure.
Spade	Scooping and carrying of soil, sand, concrete mixture and manure
Spring balance	Measuring weight.
Trowel	Scooping seedlings during transplanting and digging planting holes for seedlings.
Pruning hook	Bending tall branches when pruning.
Secateur	Cutting young stems and pruning branches.
10. Tape measure	Measuring distances.
11. Axe	Cutting big trees and roots and splitting logs of wood.
12. Soil auger	Making holes for fencing posts.
13. mattock	Digging hard soils
14. sprinklers	Overhead irrigation.
15. Watering can	Watering plants in nursery bed.
16. Wheel barrow	Transportation of soil, fertilizers, farm produce, tools and equipment.
17. Levelling board	For levelling a nursery bed.
18. Pruning saw	Cutting old wood stems and pruning big branches.
19. Hose pipe	For conveying water from a tap to where it is need.
20. Knap sack sprayer	Applying agro-chemical by spraying.
21. Garden shear	Trimming hedges.
22. Pruning knife	Removal of small shoots.
23. Meter ruler	Measuring distances.
24. Garden fork	Shallow digging.

Livestock Production Tools and Equipment

Tools	Uses
Drenching gun	Administering liquid drugs to animals orally.
Bolus gun/dosing gun	Administering solid drugs or tablets to animals orally.
Wool Shears	Cutting off wool from sheep.
Hypodermic syringe	Administering drugs by injection for example in vaccination.
Stirrup (bucket) pump	Application of acaricide by hand spraying.
Thermometer	Taking body temperatures of farm animals.
Burdizzo	Used in bloodless method of castration.
Halter	Rope designed to restrain the animal.
Trimming knife	Cutting short the overgrown hooves.
Elastrator	Stretching rubber ring during castration, dehorning and docking of lambs.
Iron dehorner	Applies heat on the horn bud to prevent growth of horns.
Nose ring	Fixed into the nose of a bull to restrain it.
Strip cup	Detecting mastitis in milk products.
Trocar and cannula	Relieving a bloated animal of gases particularly ruminants.
Hard broom	For scrubbing the floor.
Ear notcher	Making ear notches in livestock.
Bucket	For holding milk during milking.
Milk chum	For holding milk after milking.
Milk strainer/sieve	Removing foreign particles from milk for example hairs and
Rope	Tying or tethering animals.
Milking stool	Used by the milker to sit on while milking.
Weighing balance	Weighing milk after milking.
Teeth clipper	Removal of canine teeth of piglets soon after birth.
Chaff cutter	Cutting fodder into small bits.
Dehorning wire	Cutting grown horns.

Workshop Tools and Equipment

Tools	Uses		
Spanner	Tightening and loosening nuts and bolts.		
Pliers	Cutting small wires and thin metal and gripping firmly.		
Files	Sharpening tools, smoothening or shaping edges of metals,		
Rasps	Smoothening and shaping of wooden structures.		
Chisels (wood)	Making grooves in wood.		
Cold chisel	Cutting and shaping metal.		
Screw drivers	Driving screws in or out of wood or metal.		
Saws			
Cross cut saw	Cutting across the grain of wood.		
Rip saw	Cutting along the grain of wood.		
Hack saw Bow saw	Cutting metals.		
Tenonback saw	Cutting branches of trees.		
Coping saw	Cutting Joints on wood and fine sawing.		
Compass/keyhole saw	Cutting curves on thin wood.		
	Cutting either along or across the grain of wood especially		
	when cutting key holes.		
Tin snip	Cutting metal sheets.		
Braces and bits.	Boring holes in wood.	,	
Drill and bits	Boring holes in metal work and woodwork.		=
Hammer			
Claw hammer	Driving in, removing and straightening nails.		
Ball pein	Driving in nails, rivets and straightening metal. Also used		
	on cold chisel		
Mallet	Hammering or hitting wood chisel.		
Jack plane	Fine finishing of wood.		
Scrappers/spokeshave	Smoothening curved surfaces of wood such as handles of		
	jembes, axes.		
Measuring equipment		~	
Metre ruler	Measuring short length -.		
Try square			
	Measuring length angles and to ascertain squareness.		
Marking gauge	Marking parallel lines to the edge of wood.		
Fencing pliers	Cutting wires, hammering staples when fencing.		
Vice and clamps	Firmly holding pieces of work together.		

Tools	Uses
Spirit level	Measuring horizontal or vertical levels.
Soldering gun	Melting soldering rods when repairing or fabricating metal sheets.
Wire brush	Brushing rough surfaces.
Divider	Marking and laying out.
Centre punch	Marking the point of drilling.
Paint brush	Applying paint on surfaces.
Sledge hammer	Ramming hardware, breaking stones.
Wire strainer	Tightening wires during fencing.
Riveting machine	Fix rivets when joining pieces of metal.
Claw bar	Removing long nails from wood, straining fencing wires and digging fencing holes.

Plumbing and Masonry Tools

Tools	Uses
Pipe wrench	Holding, tightening and loosening metallic pipes.
Pipe cutter	Cutting PVC pipes.
Levelling rod	Levelling the floor during construction.
Mason's trowel	Placing mortar between construction stones and bricks.
Wood float	Create a level surface on walls and floors.
Mason's square	Ascertain verticalness.
Plumb bob	Spreading screed over floors and walls.
Shovel	Mixing and scooping concrete or mortar, measuring cement.

Care and Maintenance of Tools and Equipment

Reasons for Maintenance

- To increase durability.
- To increase efficiency.
- Reduce costs of replacement.
- For safety of the user/avoid accidents.
- Avoid damage to the tool.

Methods

- Use tools for the right work.
- Proper handling when using tools or equipment.
- Clean and oil tools after work.
- Keep tools in their right place.
- Replace and repair worn-out parts
- Sharpen cutting or digging edges
- Grease moving parts to reduce friction
- Use safety devices in the workshop to reduce accidents and breakage

CROP PRODUCTION 1

(Land Preparation)

Introduction

- A piece of land which is prepared is known as seedbed.
- A seedbed is a piece of land that is prepared ready to receive planting materials.

Seedbed Preparation

Reasons for Seedbed Preparation;

- To enable water to infiltrate.
- To kill weeds
- To improve soil aeration.
- To destroy pests and diseases.
- To incorporate organic matter in the soil.
- For easy planting.
- To facilitate root penetration.

Operations in Land Preparation

Land Clearing

- Clearing of land is necessary when:
- Opening up a virgin land.
- A stalk growing crop was previously planted.
- There is long interval between primary and secondary cultivation.
- Land was left fallow for a long time.

Procedure

- Tree felling and removal of stumps and roots.
- Burning
- Slashing
- Use of chemicals.

Note: Burning should be avoided where possible since it;

- Leads to loss of organic matter,
- Kills soil organisms
- Destroys soil structure and plant nutrients.

Primary Cultivation

- This is the initial breaking of land.
- It is done early before the onset of the rains to:
 - Give time for soil organisms to act on organic matter.
 - Allow gaseous exchange to take place, thus carbon dioxide diffuses out of the soil while oxygen enters into the soil.
 - Allow other operations to take place in time.

Reasons for primary cultivation:

- Remove weeds.
- Bury organic matter.
- Open up soil for infiltration of water and air.
- Expose pests and disease causing organisms.
- Soften the soil for easy planting.

Operations in primary cultivation

- ***Hand digging ;***

Use of hand tools ;

- Jembes,
- Mattocks,
- Fork-jembes.

- ***Mechanical cultivation ;***

Use of mouldboard ploughs;

- Disc ploughs,
- Chisel ploughs,
- Subsoilers
- Rippers.

- ***Use of Ox-Ploughs ;***

Which can be drawn by;

- Oxen,
- Donkeys,
- Camels

Depth of Cultivation

Depends on:

- The type of crop to be planted/size of seed.
- The implements available.
- The type of soil.

Choice of Implement

Determined by:

- The condition of land.
- The type of tilth required/type of crop.
- Depth of cultivation.

Secondary Tillage

- These are refinement practices on the seedbed that follow primary cultivation.
- It is also known as harrowing.

Reasons for secondary Tillage:

- To remove the germinating weeds.
- To break soil clods to produce required tilth.
- To level the seedbed for uniform planting.
- To incorporate organic matter/manure into the soil.

Factors determining number of secondary cultivation:

- Soil moisture content.
- Size of the planting materials.
- Condition of the soil after primary cultivation.
- Slope of the land.

Tertiary Operations:

- **Ridging ;**
 - The process of digging soil on a continuous line and heaping on one side to produce a furrow and a bund (ridge).
 - It is important for root crops, to allow root expansion and for soil and water conservation.
- **Rolling:**
 - It is the compaction of the soil to produce a firm surface which increases seed-soil contact and prevents wind erosion.
- **Levelling;**
 - Production of an even, uniform surface which promotes uniform planting.

Subsoiling:

- This is deep cultivation into the subsoil layer to break up any hardpan which might have developed.

It is done for the following reasons:-

- To facilitate drainage.
- Bring up leached nutrients to the surface.
- Increase aeration of the soil.
- To improve root penetration.
- The implements used include *chisel plough* and *subsoilers*.

Minimum Tillage:

- This is the application of a combination of farming practices with the aim of reducing the disturbance of the soil.

Examples of which include:

- Use of herbicides.
- Mulching and cover-cropping.
- Timely operations to prevent weed infestation.
- Strip cultivation.
- Uprooting and slashing of weeds.

Reasons for Minimum Tillage

- To reduce cost of cultivation.
- To control soil erosion.
- To preserve soil moisture.
- To prevent root exposure and damage.
- To reconstruct destroyed soil structure.

***This is a Property of Mwalimu Consultancy Ltd. Contact Mr Isaboke 0746-222-000
for more Educational Materials.***

WATER SUPPLY, IRRIGATION AND

DRAINAGE

Introduction

- Water is a very important natural resource.
- It is necessary for both crops and livestock.

Uses of water in the farm;

- Cleaning equipment.
- Irrigation in dry areas.
- Processing farm produce, for example, coffee.
- Drinking by livestock and man.
- Mixing agro-chemicals such as acaricide, fungicides and herbicides.
- Providing power in water mills to grind grain crops.
- Cooling engines.
- Construction work.

Sources of Water in the Farm

Three major sources of water in the farm:

- ***Surface water:***

Includes water from;

- Rivers,
- Streams
- Dams.

- ***Ground water:***

Includes water from;

- Springs,
- Wells
- Boreholes.

- ***Rain water:***

This is water tapped in various ways such as;

- Rooftops
- Rock surface, when it is raining and stored in various ways.

Collection and Storage of Water

- **Dams:**
 - These are structures constructed across rivers and channels.
 - They collect and store water for use during the dry season.
- **Weirs:**
 - These are structures constructed across rivers to raise the water level for easy pumping.
 - Unlike in the dams water flows over the barrier created across the river.
- **Water Tanks:**
 - These are structures made of concrete, stone, metal sheets and plastics.
 - They store water from rain or that which has been pumped from other sources.
 - Tanks should be covered to prevent contamination from dust.

Pumps and Pumping of Water

- Pumping is the lifting of water from one point to another by use of mechanical force.
- Water is pumped from the various sources and then conveyed to where it is required for use or storage.

Types of Water Pumps

Used to lift water from its source.

- Centrifugal pumps
- Piston or reciprocating pumps
- Semi-rotary pumps and
- Hydram

Conveyance of Water

- This is the process of moving water from one point, usually the source or point of storage to where it will be used or stored.
- **Piping;**
 - This is where water is moved through pipes.
The common types of pipes include:
 - Metal pipes
 - Plastic pipes
 - Hose pipes
- **Use of Containers:**
 - In this case water is drawn and put in containers .

- drums, jerry cans, pots, gourds, tanks and buckets .
- Which are carried by animals, bicycles, human beings and vehicles.
- **Use of Canals:**
 - In this case water is conveyed from a high point to a lower one along a gradual slope to avoid soil erosion.
 - Water conveyed through this way is mostly used for irrigation and livestock.

Water Treatment

- Raw water contains impurities which may be dissolved, floating or suspended in water.

These impurities are grouped into three categories, namely:

- ***Physical impurities:*** these are dissolved impurities detected by colour, taste and smell.
- ***Chemical impurities:*** these are dissolved impurities detected by use of chemical analysis.
- ***Biological impurities:*** these are microorganisms in water such as bacteria, viruses and algae.

Importance of Treating Water

- To kill disease causing microorganisms such as cholera and typhoid bacteria that thrive in dirty water.
- To remove chemical impurities such as excess fluoride which may be harmful to human beings.
- To remove smells and bad taste.
- To remove sediments of solid particles such as soil, sand and sticks.

Methods of Treating Water

- ***Aeration:*** this is the removal of smell and odour from water by fine spraying or bubbling of air.
- ***Sedimentation:*** this is where water is put in large containers so that solid particles such as sand, metal and others can settle at the bottom.
- ***Filtration:*** this is passing water through fine granular materials to remove solid particles and biological substances.
- ***Coagulation:*** addition of chemicals which precipitate impurities and help in softening of hard water.
- ***Chlorination:*** Sterilization to destroy disease causing organisms.

Irrigation

- It is the artificial application of water to crops in dry areas or where water is not enough.
- It is one of the methods of land reclamation in case of arid and semi arid areas.

Factors to Consider in Identifying and Assessing the Potential of Land for Irrigation Development

- Topography of the land
- Soil type
- Type of crop to be grown
- Water availability
- Human factors such as skill, capital availability and economic activities.

Types of Irrigation

- ***Surface irrigation:***
 - This includes flood irrigation and basin irrigation.
 - It is used in flat areas.
 - The problem with this method is loss of water through seepage.
 - It also increases soil salinity.
- ***Sub-surface Irrigation:***
 - This involves the use of porous pipes or perforated pipes.
 - It is used in slopy areas and where water is inadequate.
- ***Overhead or Sprinkler Irrigation:***
 - It is used in any area which is not steep.
- ***Drip or Trickle Irrigation:***
 - It is used where water is little and in relatively sloppy and flat areas.

Drainage

- This is a method of removing excess water or lowering the water table from a marshy water-logged land.
- It is also a method of land reclamation.

Importance of Drainage as a Method of Land Reclamation

- To increase soil aeration.
- To raise soil temperature.

- To increase microbial activities in the soil.
- To reduce toxic substances from the soil.
- To increase soil volume for exploitation by plant roots.

Methods of Drainage

- Use of open ditches.
- Use of underground drain pipes.
- French drains.
- Cambered beds.
- Pumping out water from the soil.
- Planting tree species which absorb a lot of water for example eucalyptus.

Water Pollution

- This is the process by which harmful substances get into the water.
- The harmful substance is referred to as a **pollutant**.

Agricultural practices which pollute water include:

- Use of inorganic fertilizers.
- Use of pesticides.
- Poor cultivation practices such as over cultivation, cultivating along the river banks.
- Overgrazing which leads to erosion of soil thus causing siltation in water sources.

Methods of Preventing Water Pollution

- Soil conservation measures which minimize soil losses through erosion.
- Fencing off the water sources.
- Adopting organic farming practices for example controlling pests and weed using non-chemical techniques.
- Planting grass along river banks to minimize siltation in rivers.
- Proper disposal of empty chemical containers.

SOIL FERTILITY I

(Organic Manures)

Introduction

- Soil fertility is the ability of the soil to provide crops with the required nutrients in their proper proportions.

Characteristics of a Fertile Soil

- **Good depth** - Good soils give roots greater volume to obtain plant nutrients and provide strong anchorage.
- **Good aeration** - for the respiration of plant roots and use by soil organisms.
- **Good water holding capacity** - ensures provision of adequate water for plant growth.
- **Proper drainage** - ensures provision of adequate air for plant growth.
- **Correct soil pH** - different crops have different soil pH requirements.
- **Adequate nutrients supply** - it should supply the required nutrients in the correct amounts and in a form available to plants.
- **Free from excessive** infestation of soil borne pests and diseases.

How soil loses fertility

- **Leaching**: vertical movement of dissolved minerals from the top to the lower horizons of the soil profile.
- **Soil erosion** - The removal and carrying away of the top fertile soil from one place to another.
- **Monocropping** - This is the practice of growing one type of crop on a piece' of a land over a long time.
- **Continuous cropping** - crops take away a lot of nutrients from the soil which are never returned.
- **Growing crops continuously** without giving the soil time to rest makes the soil infertile.

- **Change in soil pH** - changes in soil pH affect the activity of soil microorganisms as well as the availability of soil nutrients.
- **Burning of vegetation** - burning of vegetation cover destroys organic matter. It also exposes the soil to the agents of soil erosion.
- **Accumulation of salts** - soils with a lot of salts are said to be saline. State of having too much salt in the soil is referred to as soil salinity.
- Salts accumulation cause water deficiency in plants. It may also lead to change in soil pH.

Maintenance of Soil Fertility

Soil fertility is maintained through the following methods:

- **Control of Soil Erosion ;**
 - Terracing,
 - Contour cultivation,
 - Strip cropping,
 - Cut off drains
 - Planting cover crops.
- **Crop Rotation ;**
 - Practice of growing different crops on the same field in different seasons in an orderly sequence.
- **Control of Soil pH :**
 - Application of liming materials such as *limestone, quicklime, magnesium carbonate and slaked lime if the soil is acidic.*
 - Application of acidic fertilizers if the soil is alkaline.
 - Application of manures.
- **Proper drainage;**
 - Done through:**
 - Breaking hard pan.
 - Construction of water channels.
 - Growing crops on cambered bed

- Pumping out water from the soil.
- **Weed control:**
 - Use of herbicides.
 - Slashing
 - Uprooting.
 - Mulching
 - Use of proper farming practices such as early planting, correct spacing and cover crops.
- **Intercropping** –
 - Farming practice where different crops species are grown together in the field.
- **Minimum Tillage;**
 - Use of herbicides.
 - Uprooting of weeds.
 - Slashing weeds
 - Mulching
 - Strip cultivation.
- **Use of Inorganic Fertilizer ;**
 - Chemical compounds manufactured to apply specific plant nutrients for example calcium ammonium nitrate (CAN).
- **Use of Manure;**
 - Well decomposed manures release nutrients into the soil and increase its water holding capacity.

Organic Manures

- Manures are derived from plants and animal remains.
 - They supply organic matter to the soil which after decomposition releases plant nutrients.
 - The end product of this decomposition is known as humus.
 - It influences soil chemical properties and soil temperature.
 - Manures supply a wide range of essential plant nutrients.
- .

Importance of Organic Matter in the Soil

- Increases the soil water holding capacity of the soil.
- Improves soil fertility by releasing a wide range of nutrients into the soil.
- Provides food and shelter for soil micro-organisms.
- Improves the soil structure.
- Buffers soil pH/moderates soil pH.
- Reduces the toxicity of plant poisons in the soil.
- Moderates soil temperature by its dark colour.

Limitations in the Use of Manure

- They are bulky - low nutritive value per unit volume.
- Laborious in application and transport.
- They spread diseases, pests and weeds.
- Loss of nutrients if poorly stored.
- If not fully decomposed crops may not benefit from them.

Types of Organic Manures

- Green manure.
- Farm yard manure.
- Compost manure

Green Manure

- Made from green plants which are grown for the purpose of incorporating into the soil.

Characteristics of plants used for preparation for green manure:

- Have fast growth rates.
- Have high nitrogen content.
- Capable of rotting quickly.
- Capable of growing in poor conditions.

Preparation of Green Manure

- Plant the green manure crop in the field.
- Allow the crop to grow up to flowering stage.
- Incorporate it into the soil through ploughing.
- Allow the crop to decompose for two weeks.
- Prepare the field for planting the major crop.

Reasons why green manure is not commonly used/limitations:

- Most of the plants used as green manure are food crops.
- Green manure crops may use most of the soil moisture.
- Most of the nutrients are used up by soil micro-organisms in the process of decomposing the green manure.
- Planting of the major crop is delayed.

Farm Yard Manure (FYM)

- Is a mixture of animal waste and crop residues used as beddings in animal houses.

Factors that Determine the Quality of FYM

- The types of the animals used.
- Types of food eaten
- Types of litter used.
- Method of storage.
- Age of farmyard manure.
- Age of the animals used.

Preparation of FYM

- Provide beddings in the houses of farm animals.
- Animals deposit their droppings and urine on the beddings.
- Animals mix them through trampling.
- The beddings together with dung are removed and heaped under shed to decompose.
- After sometime, the materials decompose and FYM is formed.
- It can then be used in the farm

Compost Manure

- Is manure prepared from heaped (composted) organic materials.

Factors to consider in selecting site for making compost manure:

- A well drained place.
- Direction of the prevailing wind.
- Size of the farm.
- Accessibility.

Preparation of Compost Manure

Two methods:

- *Four heaps method*
- *Indore Method (Pit Method)*

Indore Method (Pit Method)

Procedure ;

- Select a sheltered place with a shade and near the field.
- Dig a pit with the dimension 1.2m x 1.2m x 1.2m.
- Place the materials in the following order:
 - Hedge cuttings or maize stalks to a depth of 30cm as a foundation
 - A layer of grass, green weeds or leaves and kitchen wastes to 30cm.
 - A well rotten manure/poultry droppings.
 - Wood ash and phosphatic fertilizers.
 - A layer of topsoil to introduce microorganism for the decomposition of organic remains.
- *Note:* Some water should be sprinkled to the materials to initiate the decomposition process and regulate temperatures.

Four heaps method:

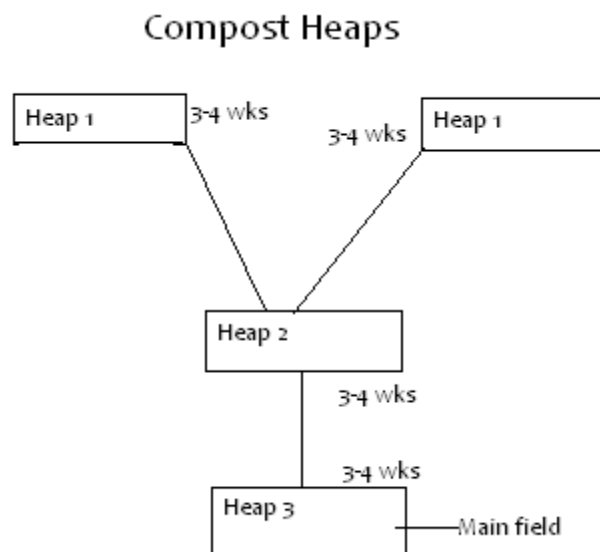

Procedure

- Clear the site.

- Level the site
- Four posts 2m high are fixed 1.2m apart from four corners of the heap.
- Fix wood planks on the sides.
- Materials are placed in two heaps as in the pit method,
- The two heaps make up heap 1.
- After 3-4 weeks, the decomposed material from heap 1 is transferred to heap II.
- After another 3 - 4 weeks the material is transferred to heap III.
- After 3-4 weeks it is ready for use in the farm.

Indicators of well decomposed manure

- Absence of bad odour.
- Materials are lighter.
- Manure is brown in colour.

Advantages of Compost Manure

- One does not have to own livestock in order to prepare it.
- A lot of manure can be produced within a short time.
- A variety of materials can be used in its preparation.
- Uses locally available materials thus cheaper than the artificial fertilizers.
- Improves the soil structure.

Limitations of Compost Manure

- It releases nutrients slowly into the soil.
- Large quantities of compost manure are required to supply enough plant nutrients.
- Its preparation is labour intensive.
- It may induce soil-borne pests and diseases.

***This is a Property of Mwalimu Consultancy Ltd. Contact Mr Isaboke 0746-222-000
for more Educational Materials.***

LIVESTOCK PRODUCTION:

(Common Breeds)

Introduction

- The term livestock is used to refer to all domesticated animals.
- These animals include cattle, sheep, goats, poultry, pigs, rabbits, camels, bees, fish and donkeys.

The importance of keeping livestock:

- Source of food.
- Source of income.
- Cultural values.
- Source of animal power.
- Provision of raw materials for industries.
- Farmyard manure from the animals is used in maintaining soil fertility.
- Cattle dung is used in the production of biogas.

Cattle Breeds

- Cattle can be classified into two groups based on their origin.

These are;

- Indigenous cattle.
- Exotic cattle.

Indigenous Cattle

- ***Zebus*** –

They are small in size and with a distinct hump and include:

- Nandi,
- Bukedi
- Maasai cattle.

- ***The Borana***

- These are the cattle kept in the Northern parts of Kenya.
- They are larger than the Zebus.

- Indigenous cattle are hardy hence able to tolerate the harsh environmental conditions in the tropics.
- They are the major suppliers of beef in Kenya.

Exotic Cattle

- Foreign cattle from the temperate regions.
- They have distinct breed characteristics and are classified into various breeds.

General characteristics:

- They have no humps.
- They have low tolerance to high temperatures hence popular in cool climates of the Kenya highlands ..
- They are highly susceptible to tropical diseases.
- They have fast growth rates leading to early maturity.
- They are good producers of both meat and milk.
- They cannot walk for long distances.
- They have short calving intervals of one calf per year if well managed.

Exotic cattle breeds fall under the following groups:

- Dairy cattle breeds.
- Beef cattle breeds.
- Dual purpose breeds.

Dairy Cattle Breeds

- They include;
- Friesian,
- Ayrshire,
- Guernsey
- Jersey.

Characteristics of Dairy Cattle

- Wedge or triangular in shape.
- Large stomach.
- Docile with mild temperament.
- Large, well suspended udders and teats.
- Lean bodies.

- Lean and smooth neck.
- Large and long mammary milk wells and veins.
- Cylindrical; uniform and well spaced teats.
- Wide and well set hindquarters to accommodate the udder.

Friesian-Holstein (largest of all dairy breeds)

- ***Origin:*** Holland
- ***Colour:*** Black and white
- ***Size:*** Cow weighs 550-680kgs Bull weighs 950 kg.
- Highest milk producers of all dairy breeds about 9150 kg per lactation but with least butterfat content; 3.5%

Ayrshire

- ***Origin:*** Scotland
- ***Colour:*** White with brown markings.
- ***Size:*** Cow weighs 360-590kgs Bulls weighs 500-720kg.

Conformation:

- Straight top lines, horns are long and face upwards.
- Milk production is second to Friesian about 6100kg per lactation with butter content of about 4%.

Guernsey

- ***Origin:*** Guernsey Island off the coast of France.
- ***Colour:*** Yellowish brown to red with white legs, switch and girth ..
- ***Size:*** Bulls 540-770kg. Cow weighs 450- 500kgs

Conformation:

- Udders are less symmetrical.
- Average milk production is about 5185kg per lactation with a butterfat content of 4.5% hence the yellow colour of milk.

Jersey (smallest of all the dairy breeds)

- ***Origin:*** England
- ***Colour:*** Yellow brown with black muzzle and switch.
- ***Size:*** Bulls weigh 540-700kg. Cow weighs 350-450kgs

Conformation:

- Dished forehead, have straight top-line and level rumps with sharp withers.
- Have protruding black eyes.
- Average milk production 1270kg per lactation of butterfat content 5%.
- They tolerate high temperatures.

Beef Cattle

Examples:

- Aberdeen Angus,
- Hereford,
- Shorthorns,
- Galloway,
- American Brahman,
- charolais
- Santa Getrudis.

Characteristics of Beef Cattle

- Blocky or square conformation.
- Have thick muscles or are well fleshed.
- Early maturing.
- Deep chest and girth and short legs.
- Straight top and lower lines.

AberdeenAngus

- **Origin:** North East Scotland.
- **Colour:** Black
- **Shape:** Cylindrical, compact and deep; It is polled.

Size:

- Mature bulls weigh 900kg.
- Mature cows weigh 840kgs.
- It is found in Timau area of Kenya

Hereford

- **Origin:** England.
- **Colour:** Deep red and white-faced.
- **Size:** Average weight of bulls is 1000kg.
- Cows weigh 840kgs.
- It is found in areas such as Naivasha.

Shorthorn

- **Origin:** England.
- Has easy fleshing ability
- **Colour:** Red, Roan or white
- **Shape:** Cylindrical, compact and deep.
- It is polled.

Size:

- Bulls weigh 700-900kg,
- cows weigh 545-630kgs.

Galloway

- **Origin:** Scotland.
- **Colour:** Black
- Kept in the highland areas like Molo in Kenya.

Charolais

- **Origin:** France.
- **Colour:** Creamy white.
- **Size:** Bulls weigh 1200kg, cows weigh 1000kgs.
- It is found in ranches in Laikipia District.

Dual Purpose Breeds

Examples: Sahiwal, Red Poll and Simmental.

Sahiwal

- **Origin:** India and Pakistan ..
- **Colour:** reddish brown.
- **Size:** Bulls weigh 650kg, and cows 400kg.

- Milk production averages 2700-3000 per lactation with a butter fat content of 3.7%.
- It has a pendulous udders which does not let down milk easily.
- It is therefore said to be a difficult milker.
- It is kept in semi-arid areas such as Naivasha.

Red Poll

- ***Origin:*** England.
- ***Colour:*** Deep red with a white nose.
- ***Conformation:*** Polled-deep girth and short legs.
- ***Kept in semi-arid*** areas such as Nakuru, Mogotio.

Simmental

- ***Origin:*** Switzerland.
- ***Colour:*** Light red and white patches on the head.

Conformation:

- It has broad and straight back, with well-sprung ribs and deep girth.
- It is well fleshed at rear quarters, well suspended udders and large teats.

Sheep Breeds:

Purpose of Keeping Sheep;

- Meat (mutton).
- Wool production.

Exotic Sheep

- ***Wool breeds*** -for example merino.
- ***Dual purpose-*** for example Corriedale, Romney marsh.
- ***Mutton breeds*** -for example Hampshire Down, Dorpers.

Merino

- ***Origin:*** Spain

Characteristics:

- It has white face and its lips and nostrils are pink in colour.
- Rams have horns which are spiral in shape.
- It is susceptible to foot rot, worm and respiratory diseases.

Corriedale

- ***Origin:*** New Zealand.
- ***Size:*** Rams 85 - 90kg. Ewes 60-- 85 kg
- This is a dual-purpose breed with white open face and white spots on the legs.
- It is hornless and hardy.

Romney Marsh

- ***Origin:*** England.
- ***Size:*** Rams 100 - 115kg.
- Ewes 84- 100 kg
- It is a dual-purpose breed which s hornless with wide poll and black nostrils and lips.
- It is average in prolificacy.
- It is resistant to foot rot diseases and worm infestation.

Hampshire Down

- ***Origin:*** England.
- ***Size:*** Rams 125kg.
- Ewes 80-100 kg
- It is a mutton breed which is early maturing, hardy and prolific.
- Fleece is of poor quality because of the black fibres.
- Lambing percentage is 125-140.

Dorper

- Is a crossbreed of Dorset horn and black head Persian sheep.
- It is mutton breed.

Dorset Horn

- Dual purpose breed of sheep.
- Indigenous Breeds of Sheep
- Their bodies are covered with hair.
- Their classification is based on their tails and their names vary according to different tribes.

Characteristics;

- Thin tailed sheep found in West Africa.
- Fat tailed such as Maasai sheep.
- Fat rumped sheep.

Maasai Sheep

- Found in South Western Kenya and Northern Tanzania.
- Size: Ram 38kg,
- Ewe 20-30kg.
- Colour: Red and brown.
- These are early maturing with long legs and small pointed horns.

Black Head Persian Sheep

- **Origin:** South Africa
- **Colour:** White with black head and neck.
- It is polled with a big dewlap, fat rump and a curved tail..

Goats

Goats well adapted to a wide range of environmental conditions because of the following characteristics:

- They feed on a wide range of vegetation.
- They require very little amount of water.
- They are tolerant to high temperatures.
- They are fairly resistant to diseases.
- They can walk long distances without losing weight.

Indigenous Goat Breeds

- Galla (white in colour). Adult female can weigh 25kg.
- Somali (Boran): Found in Northern Kenya (white in colour).
- Turkana/Samburu: (Long hair and bearded).
- Mubende: (Black) (40-45kg). These are small and hardy and are kept for meat and milked by the pastoralists.

Exotic Breeds

Boer goat

- **Origin:** South Africa
- **Colour:** White
- Has long ears and long hair on their bodies.

Anglo-Nubian

- **Origin:** North East Africa
- **Colour:** Roan and White
- These have long legs, lopped ears and are polled.
- They produce 1-2 litres of milk per , day.

Jumnapari

- **Origin:** India
- **Colour:** White, black and fawn.
- They are horned, have large lopped ears
- Produce 1-1.5_litres of milk per day.

Toggenburg

- **Origin:** Switzerland
- **Colour:** White patches on the body, white stripes on the face and neck.
- Erect forward pointing ears and polled.
- Can produce 2-3 of milk per day.

Saanen

- **Origin:** Switzerland.
- **Colour:** White
- They have erect, forward pointing ears and polled.
- Can produce 2-3 litres of milk per day.

Angora

- **Origin:** Angora in Asia.
- **Colour:** White
- It is kept for wool production.

French alpine. Pigs

Characteristics:

- They are sparsely haired and therefore cannot withstand cold.
- Pigs wallow when it is hot due to absence of sweat glands.
- They breathe fast when it is hot.
- They have bristles instead of hair.

Breeds

Large White

- ***Origin:*** Britain
- _ Kept for bacon and pork production.
- Long, large and white in colour.
- Ears straight and erect.
- Has dished face and snout.
- Most prolific and with good mothering ability.
- Fairly hardy.

Landrace

- ***Origin:*** Denmark
- White and longer than large white. _
- Ears drooping.
- Good for bacon production.
- Very prolific with good mothering ability. _
- Requires high level of management.

Wessex Saddle

- ***Back Origin:*** England
- ***Colour:*** Black with white forelegs and shoulders.
- Straight snout and drooping ears. _
- Good for bacon and pork.
- Good for keeping outdoors.
- Excellent mothering instincts.

Other pig breeds include:

- Berkshire,
- Middle-white
- Duroc Jersey pig.

Pigs can be crossed to obtain hybrids or crosses.

Advantages of Crosses

- Increased litter size. _
- Early maturing.
- _ Increase in body length.
- _ High proportion of lean meat to fat.

Poultry Breeds

There are three types of chicken breeds:

- The light breeds kept for egg production.
- The heavy breeds kept for meat production.
- Dual purpose breeds - kept for both eggs and meat production.

Characteristics of Light Breeds

- Never go broody hence poor sitters.
- Excellent layers (over 220 eggs per year).
- Poor meat producers (hens can attain 2kg; cocks 3kgs)
- Very nervous and exhibit high degree of cannibalism.
- Hen's comb is large and bent over one eye and cock's comb is large with 5 - 6 serrations.

Examples:

- Leghorns,
- Anconas,
- Silkies,
- Minorcas.

Characteristics of Heavy Breeds

- Can lay few eggs and provide good meat as broilers.
- Can go broody.
- Heavier and bigger in size.
- Grow fast.

Examples:

- Light Sussex,
- Cornish Dark
- White.

Characteristics of Dual-Purpose Breeds

- Go broody.
- Have good meat.
- Disease resistant (do not require high standard of management).
- Rarely exhibit cannibalism.

Examples: Rhode Island Red.

Hybrids

- These are developed by crossing two different breeds.
- They are superior in performance.
- Can attain 2kg in 56 days for broilers and layover 200 eggs per year for layers.

Examples:

- Shavers,
- Thombers
- Isabrown.

Rabbits

Kept for the following reasons:

- To provide meat, fur, hair or wool.
- To provide skin for leather.
- To provide manure.
- As pet animals.
- Used for research purposes.

Breeds

- **Californian white:** white, very prolific black ears, nose and feet).
- **New Zealand white:** (white with pink eyes - good for meat).
- **Flemish giant** (dark grey - good for meat).
- **Angora rabbit** (white, kept for wool production).
- **Chinchillah** (greyish, kept for its fur).
- **Earlops** (white with droopy ears).
- **Kenya white** (white, smallest of breeds).

Camels

Kept for;

- Transport,
- Racing,
- To provide milk, meat and wool.

There are two species of camels.

Dromedary (*Camelus dromedarius*)

- **Origin:** Arabia and Syria
- Are single humped, have light body
- Good for racing and rapid transport.

Bacterian (*Camelus bacterianus*)

- **Origin:** Central Asia
- Has double humps, heavier and has shorter legs.
- Can live in cold regions hence its thick and long coat acts as insulation.
- Capable of shedding the coat during spring.

Terms used to describe livestock in different age, sex and use.

Livestock	Adult		Replacement Stock		Young	Users)
	Male	Female	Male	Female	One	
Cattle	Bull	Cow	Bullock	Heifer	Calf	Dairy - milk Beef-meat
Sheep	Ram	Ewe	Ram	Hogget	Lamb	Mutton - meat Wool sheep -wool
Goat	Buck or	Doe or	Buck	Doe	Kid	Dairy - milk
			Billy	Nanny		Mutton - meat
Pigs	Boar	Sow	Boar	Gilt	Piglet	Pork - meat
						Bacon -cured
Poultry	Cock	Hen	Cockerel	Pullet	Chick	Broilers - meat
						Layers - eggs
Rabbits	Buck	Doe	Buck	Doe	Kindling	Meat
Camel	Bull	Cow	Bull	Heifer	Calf	Pack, trained for
						riding, racing
						meat, fur

This is a Property of Mwalimu Consultancy Ltd. Contact Mr Isaboke 0746-222-000

for more Educational Materials.

AGRICULTURAL ECONOMICS I

(Basic Concepts and Farm Records)

Introduction

- Economics is the study of how man and society chooses to allocate scarce productive resources to produce various commodities, over time, and distribute them among various consumers in society.
- It attempts to explain how man can best use the limited resources to produce goods and services which satisfies his needs with minimum wastage or loss of these resources

Example;

- food,
- clothing
- shelter
- Agricultural economics is therefore defined as a science that aims at maximizing output while minimizing costs by combining the limited supplies of goods and services for use by the society over a certain period of time.
- **These are;**
 - land,
 - capital,
 - labour
 - management

Basic economic Principles

Scarcity

- Economic scarcity means resources are limited in supply relative to demand.
- This principle implies that there is no time that man can have enough resources to satisfy all his need or desires

Choice/Preference

- Human wants are many and varied and means of satisfying them are limited.
- Therefore, man has to make a choice among the alternatives in order to use the resources available.
- Man does this by satisfying the most pressing needs first.
- This is called **scale of preference**.

Opportunity Cost

- Opportunity cost is the revenue forgone from the best alternative.
- It exists only where there are alternatives.
- Where there are no alternatives the opportunity cost is equal to zero.
- Opportunity cost helps in decision making.

Farm Records

- Farm records are documents kept in the farm
- They show farm activities carried out over a long period of time
- Or information kept in the farm in written form, about the farm and all activities in it.

Uses of Farm Records

- Show the history of the farm
- Show whether the farm is making a profit or loss.
- Show all the assets and liabilities of the farm which can be used to value the farm.
- Help in supporting insurance claims on death, theft, fire or loss of farm assets.
- Help in tax assessment to avoid over taxation.
- Used as a guide in planning and budgeting.
- Helps to detect losses or theft in the farm.
- Make it easy to share profits or losses in partnerships.
- Help in settling disputes among heirs to estate if the farmer dies without a will.
- Provide labour information on terminal benefits for a worker.

Type of Farm Records

- **Production Records** - Show the total yield and yield per unit of each enterprise.
- **Inventory Records** - A record of all permanent and consumable goods in the farm.

Consumable Goods Inventory

<i>Date</i>	<i>Commodity</i>	<i>Quantity</i>	<i>Date</i>	<i>Issued to</i>	<i>Quantity</i>	<i>balallce</i>
	<i>Item</i>					<i>Stock</i>

- **Field Operation Records** - Show in details all field practices carried out together with the input used for all the crop enterprises.
- **Breeding Records** –
 - Show all the breeding activities in the farm.
 - From these records it is possible to select the prolific animals and cull the infertile ones.
- **Feeding Records** – A record of the types of feeds used in the farm and their quantities.
- **Health Records** –
 - Indicates the health conditions of the animals in the farm.

From these records it is possible to:

Select and cull animals on health grounds.

***This is a Property of Mwalimu Consultancy Ltd. Contact Mr Isaboke 0746-222-000
for more Educational Materials.***

F1 TOPICAL REVISION

QUESTIONS

***A SERIES OF TOPICAL REVISION
AGRICULTURE QUESTIONS IN THIS
CLASS.***

***An Intensive Analysis of Past KCSE
Questions. Candidates are Hereby
Advised to Keep attention to this
Crucial Quick Revision Kit.***

For Marking Scheme/Answers

CALL/WHATSAPP 0746 222 000

INTRODUCTION TO AGRICULTURE

This topic entails the following:-

- **Definition of agriculture**
- **Main branches of agriculture**
- **Farming systems**
- **Farming methods**
- **Role of agriculture to Kenya's economy**
- **Varied opportunities in agriculture.**

The following relevant questions and their answers in this topic will help and motivate the user to comprehend and understand the required concepts and practices:

1. Give **two** factors which characterize intensive farming
2. State **three** reasons why organic farming is encouraged in farming
3. State **two** ways in which agriculture contributes to industrial development
4. State **four** ways by which wind affects the growth of crops
5. State **one** physical characteristic used in classifying soil
6. Outline **four** advantages of organic farming
7. State **two** conditions under which shifting cultivation is practiced
8. Differentiate between the following terms as used in Agriculture:-
 - (a) Oleculture and floriculture
 - (b) Apiculture and aquaculture

FACTORS WHICH INFLUENCE AGRICULTURE

In this topic, the following factors influence agriculture.

- Human factors e.g. -level of education, -Health HIV/AIDS, -Economic status of the farmer e.t.c
- Biotic factors e.g. pests, parasites, decomposers, pathogens, pollinators, predators e.t.c.
- Climatic factors e.g. rainfall, temperature, wind and relative humidity, light
- Edaphous factors e.g. type of soils, soil profile, soil structure, soil texture, soil chemical properties.

The following relevant questions and their answers in this topic will greatly help and motivate the user to comprehend and understand the required concepts:

1. State **two** roles of humus in the soil that are beneficial to crops
2. a) outline **five** activities that may be undertaken in organic farming
3. List **four** effects of temperature on crop growth
4. State **four** ways by which wind affects the growth of crops
5. Name **two** factors related to light that affect crop production and distribution in Kenya
6. Describe the environmental conditions that may lead to low crop yields
7. List **three** environmental factors that affect crop distribution in Kenya
8. State **one** physical characteristic used in classifying soil
9. Outline **four** advantages of organic farming
10. The diagrams below show an experiment carried out by a form 1 class. Study them carefully and

answer questions that follow:

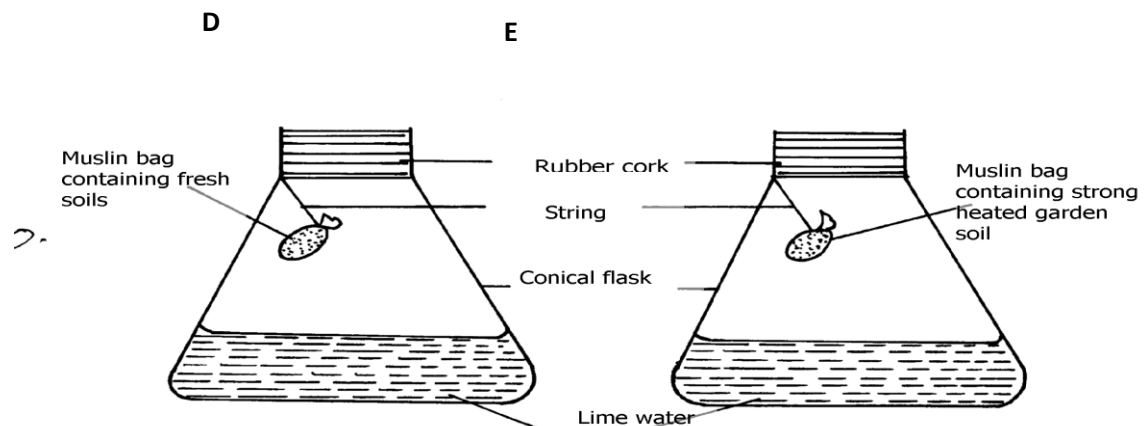

- (a) What was the aim of the experiment?
 - (b) What was the observation that form 1 students made at the end of the experiment in flasks **D** and **E**?
 - (c) Give the reason for the observation made in flask **D**
12. Briefly explain how sub-soil as a horizon in a soil profile can affect soil productivity
 13. (a) What are the **three** aspects of light that are important to a farmer?

(b) Mention **three** ways through which relative humidity affect crop production

14. The diagram labeled **E** and **F** below illustrates some type of soil structure. Study the diagrams

carefully and answer the questions that follow:

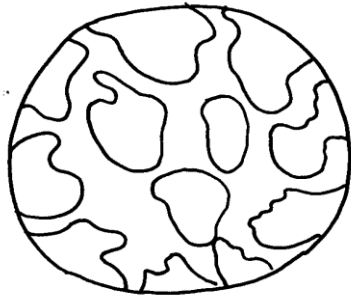

E

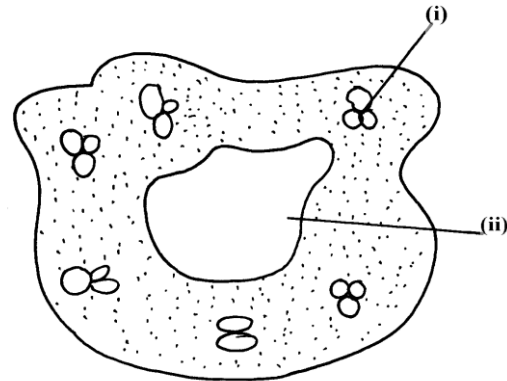

F

(a) Identify the types of soil structure illustrated in diagrams **E** and **F**

(b) Identify the parts labeled **(i)** and **(ii)** in diagram **F**

(c) Outline the influence of physical characteristics of soil on its properties

15. State **three** physical characteristics of soil

16. Study the diagram below and answer the questions that follow

a) State merits of horizon **A**

b) State distinct features of horizon **B**

c) What does the term **transition zone** refer to in soil profile

i) Name horizon **C** and state its importance

17. Outline **two** ways temperature affects crop production

18. List **four** ways by which biological agents can enhance the process of soil formation

19. List **four** environmental factors that affect crop production in Kenya

20. Explain the role played by topography in soil formation

22. Mention **two** importance of parent's material in soil profile

23. Mention **four** ways of modifying soil temperature in crop production

24. a) Mention **two** factors that affect selectivity of herbicides

b) Name **two** farming practice that cause water pollution

25. Give **four** factors that influence soil formation

26. State **three** properties of soil that is influenced by soil texture

27. Name any **three** agents of biological weathering

FARM TOOLS AND EQUIPMENTS

There are five categories of farm tools and equipment namely:

- Garden tools and equipment e.g. pangas, jembe, pick axe, spade e.t.c.
- Workshop tools and equipment e.g. saws, hammers, planes, chisels e.t.c
- Livestock production tools and equipment e.g. milking stool, strip cup, milk churn etc.
- Masonry tools and equipment e.g. wood float, spirit level, plumb bob e.t.c
- Plumbing tools e.g. pipe wrench spanner, stock and die e.t.c

It is very important to identify the farm tools and equipment, give the correct users and maintenance practices.

The following relevant questions and their answers in this topic will greatly help and motivate the user to comprehend and understand the require concepts and practices:

1. List **four** maintenance practice carried out on a cross-cut saw
2. Identify the following tools and state their functions



Identify A, B, C, D

3. Study the illustration below and answer the questions that follow.

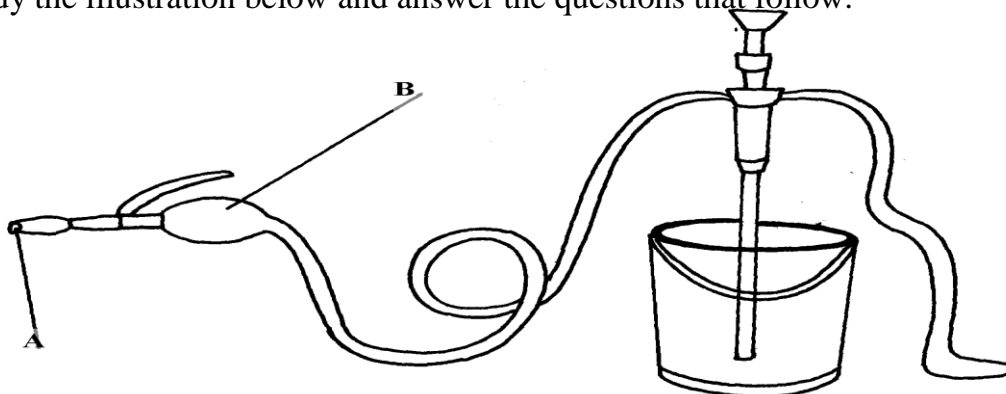

- i) Identify the equipment represented by the illustration
 - ii) What is the use of the equipment?
 - iii) Name the parts labeled **A** and **B**
 - iv) What is the function of the part labeled **A** and **B**
4. What is the use of a garden fork?
5. Name the tool that a builder would use to check the vertical straightness of a wall during construction
6. Name the farm tool that can be used when removing nails from timber
7. Give **two** examples of equipment that a livestock farmer can use in administering oral anti helminthes

8. Below are farm tools, study them and answer the questions that follow:-

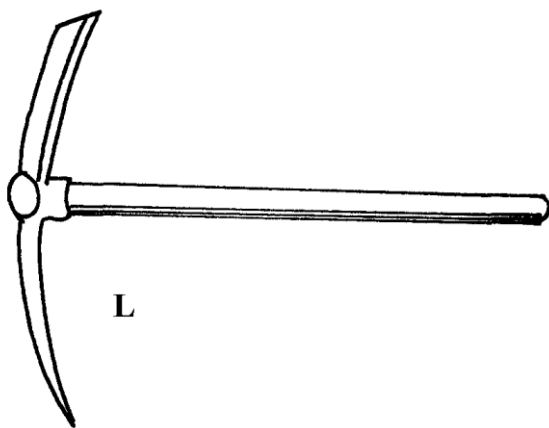

.....

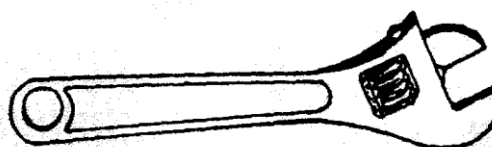

M.....

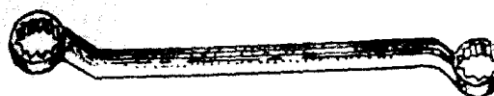

N.....

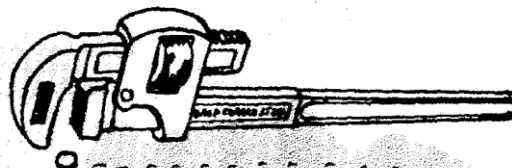

O.....

- (a) Identify the tools L, M, N, O
(b) **Give one** functional advantage of tool **M** over tool **N**
9. Name a tool used to perform the following functions on the farm;
(i) Drilling of small holes on metal
(ii) Bore holes on wood
10. State the common faults in the operation of Knapsack spray
11. (a) Name the **three** tools in castration of livestock
12. Name the most appropriate set of animal handling tools that a farmer uses for the following operations:-
- (i) Restraining a large bull when taking it around the show ring
- (ii) Cutting tail in sheep
13. a) Given below is an illustration of one of the routine management practices in livestock Production.
Study the diagram and answer the following questions



- i) Name the practice indicated in the diagram above
ii) Describe the procedure you would follow when carrying out the practice named in (i) above in piglets

14. Study the diagram below and answer the questions that follow;

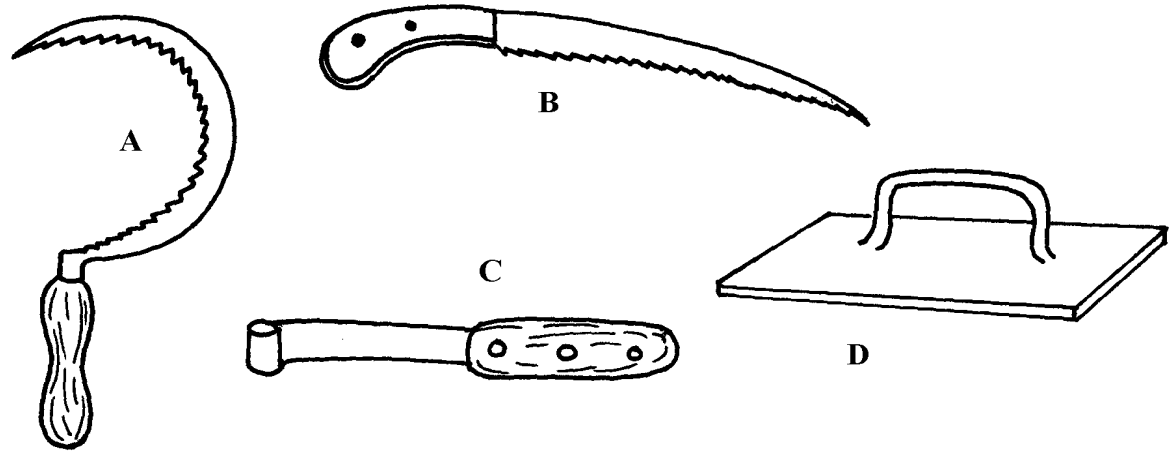

- i) Identify the tools
 - ii) Give the use of each of the tools named above
 - iii) State **two** maintenance practices that should be carried out on tool **D**
15. List **two** equipments used in handling cattle during an Agricultural exhibition
16. Mention the use of the following tools.
- i) Dibber
 - ii) Spokeshaves
 - iii) Tinsnips
 - iv) Burdizzo
17. List **four** precautions that should be taken when using workshop tools and equipment.
18. Use the diagram below to answer questions which follow

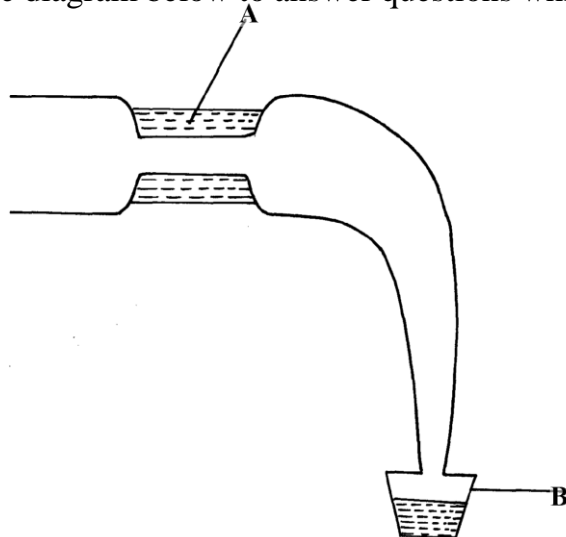

- i) Identify the above diagram
- ii) Name the parts labelled **A** and **B**

19. The diagrams below are of farm tools and equipment. Study them and answer the questions that follow

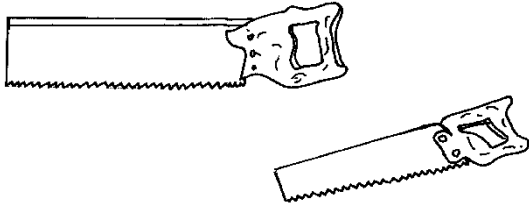

- i) Identify the tools 1 mk
- ii) Give one functional difference between the tools above. 1 mk

20. The diagram below show farm equipment. Use them to answer the questions that follow.

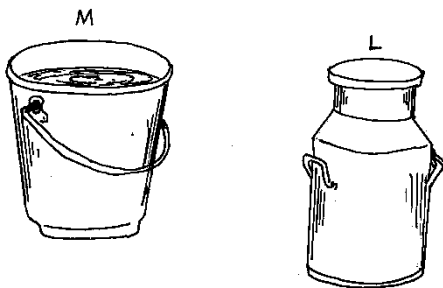

- a) Identify the equipments M and L. (1mk)
- b) State the functional difference between M and L. (2mks)
- c) State TWO common maintenance practices carried out on both M and L. (2mks)

21. Study the diagrams below and answer the questions that follow.

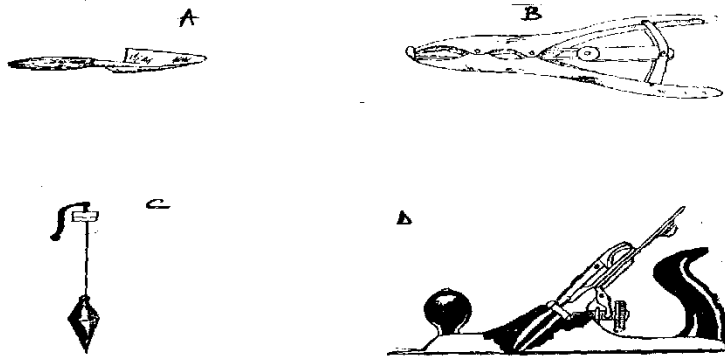

- (a) Identify the tools. A-B-C-D (2mks)
 - (b) State the correct use of each of the tools above. (2mks)
 - (c) Give two maintenance practices carried out on tool D for efficient use. (1mk)
22. (a) Name four types of tools used in smoothing wood. (2mks)
- (b) Give three reasons why farm tools and equipment should be well maintained. (1 1/2mk)

23. Study the diagrams of garden tools shown below and answer the question that follows

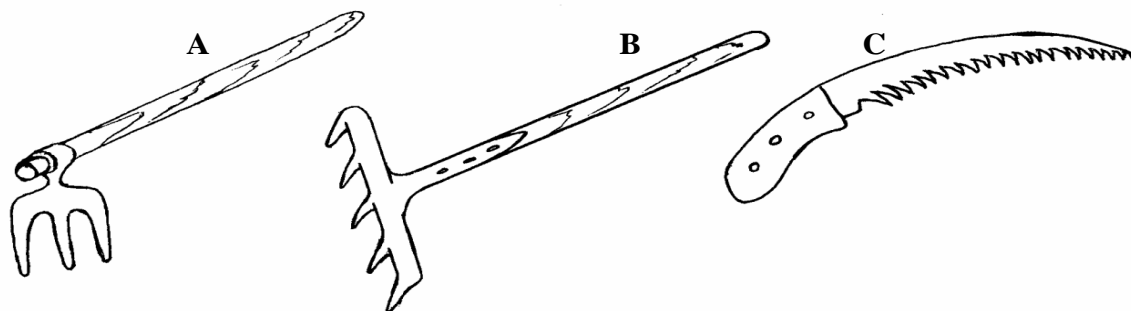

- (i) **State two** field conditions under which tool **A** would be more suitable for use in crop Production (2mks)
- (ii) **Give** the function of the tool labelled **C**. (1mk)
- (iii) **State two** maintenance practices of the tool labelled **B**. (2mks)

24. Study the diagrams below labeled P,Q,R and S representing some workshop tools and then answer the questions that follow.

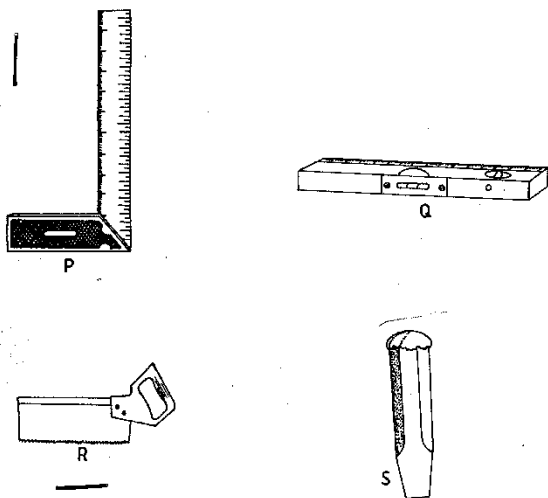

a) identify the tools 2mks

Tool	Name
P
Q
R
S

b) Give one use of tools P and R in the construction of a wooden feed trough. 1mk

P

R.....

c) How would the tool labelled Q be used in the construction of a calf pen? ½ mk

d) Give two maintenance practices carried out on tool S. 1mk

CROP PRODUCTION I (LAND PREPARATION)

- Land preparation entails the following farming practices.
- Land clearing or bush clearing tools, chemicals and equipment used.
- Primary cultivation, tools and equipment as machines used.
- Primary cultivation, tools and equipment as machines used.
- Secondary cultivation, tools and equipment used.
- Tertiary operations e.g. ridging, rolling and leveling.
- Sub-soiling, tools used and reasons for the same.
- Minimum tillage and reasons for the same.

The following relevant questions and their answers in this topic will greatly help and motivate

the user to comprehend and understand the required concepts and farming practices:

1. Give **three** factors that determine depth of ploughing during land preparation
2. List **four** reasons for cultivating land before planting
3. (a) What is minimum tillage?
(b) Give four farming practices that help in achieving minimum tillage.
4. (a) Describe the establishment of grass pasture from the time the land is ploughed using a mould board plough to the time the pasture is ready for grazing
(b) Explain **five** practices that a farmer should carry out to ensure uniform germination of seeds
(c) Describe **five** factors that determine the number of cultivations when preparing a seedbed
5. State **four** physical conditions of the seedbed that need to be changed to facilitate germination
6. State **four** importance of sub soiling as a tertiary operation
7. Outline **four** advantages of rolling in seedbed preparation
8. State **four** disadvantages of minimum tillage
9. The diagram below illustrate a tertiary operation carried out in the farm

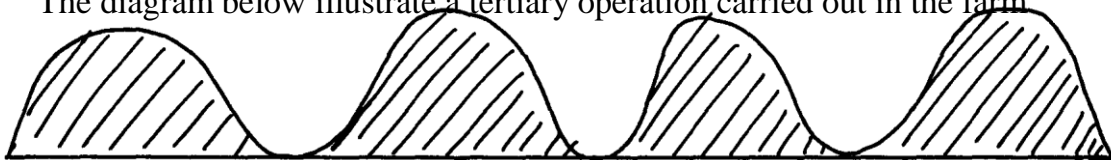

- a) Identify the tertiary operation
- b) (i) State the importance of the tertiary operation identified in **20(a)** above
(ii) Give **two** other tertiary operations carried out in the field besides the one identified above
10. Give **two** reasons why it is advisable to cultivate the field during the dry season
11. How are hard pans caused by cultivation?

12. Give **four** factors that determine the number of secondary cultivation operations
13. Define the term minimum tillage
14. List four advantages of timely planting
15. State any **two** factors that determine the number of cultivation on a field before it is ready for
planting
17. Give **three** benefits of timely planting of annual crops
18. State **four** factors determining the depth of ploughing land

WATER SUPPLY, IRRIGATION AND DRAINAGE

This topic entails the following:

- Hydrological cycle
- Sources of water on the farm
- Water collection and storage
- Pumps and pumping of water
- Types water pipes
- Water treatment
- Uses of water on the farm.
- Types of irrigation advantages and disadvantages.
- Importance and methods of drainages
- Water pollution causes and prevention.

The following relevant questions and their answers in this topic will greatly help and motivate the user to comprehend and understand the required concepts and practices:

1. State **two** reasons for treating water for use on the farm
2. State **three** reasons for draining swampy land before growing crops
3. Use the diagram below of irrigation method to answer the questions that follow.

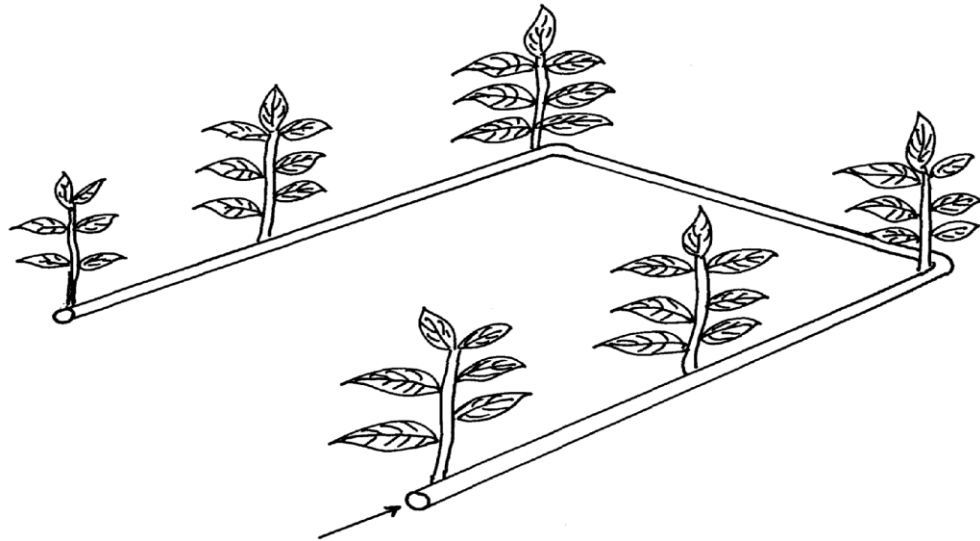

- a) Identify the method of irrigation
 - b) State **four** advantages of the above irrigation system
 - c) State **three** factors that determine the type of irrigation on the farm
 - d) State **two** disadvantages of the above system of irrigation
4.
 - a) What is **irrigation**
 - b) Outline **three** methods of irrigation
5.
 - a) List **four** uses of water on the farm

- b) Give **four** methods of harvesting water on the farm
- c) Outline the stages involved in water treatment process
- 6. List any **four** uses of water in the farm
- 7. State **two** types of irrigation used in Kenya
- 8. Outline **four** disadvantages of cambered beds
Describe the process of water treatment
- 9. Give **four** roles of drainage as a method of land reclamation
- 10. Name **two** types of water pumps which can be used in the farm
- 11. Name any **four** examples of working capital in maize production
- 12. List **four** types of water pumps which can be used in the farm
- 13. State **four** methods of drainage
- 14. Distinguish between **a dam** and **a weir**
- 15. How do the government control prices of essential farm produce
- 16. What is the difference between pumping and piping of water in the farm?
- 17. List four reasons of draining water logged soils before planting.
- 18. Give three Agricultural practices which lead to water pollution
- 19. The diagrams below illustrate some methods of irrigating crops in the field. Study the diagrams

and answer the questions that follow:

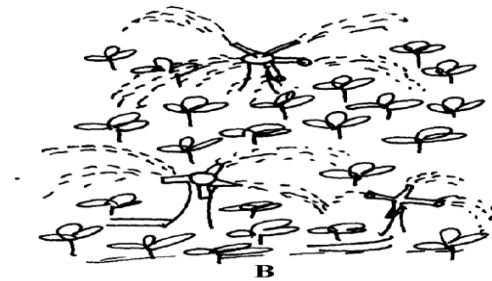

- (a) Identify the methods used ; (i) A (ii) B
- (b) State **two** advantages of method **A** over method **B**
- (c) What material should be inserted at point **T**
- b) Name **two** farming practice that cause water pollution
- 20. Give **four** reasons for practicing irrigation
- 22. a) State **four** importance of water to plants

- b) State **four** reasons for treating water before use
- c) Describe water treatment system in a chemical treatment plant
- 23. Name **four** diseases caused to man by drinking untreated water
- 24. State the functions of the following chemicals as used in water treatment;
 - (a) Chlorine.
 - (b) Aluminum sulphate (Alum)
- 21. The diagrams labeled **S** and **T** illustrate some methods of draining waterlogged fields; use it to

answer the questions that follow:

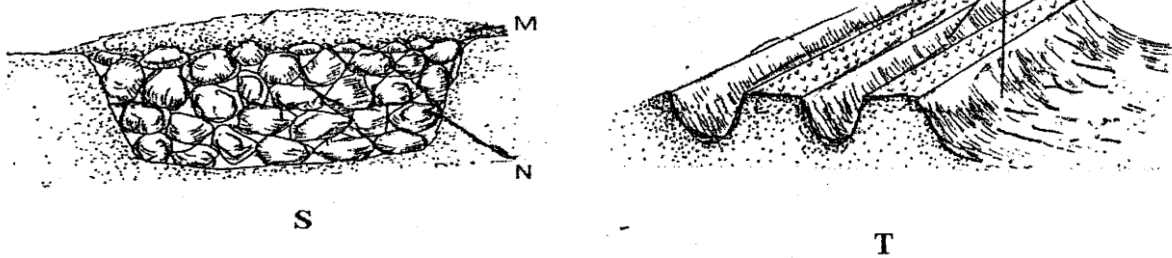

- (a) Identify the methods illustrated
- (b) What are the materials in **S** labeled **M** and **N**
- (c) Name **two** types of crops that can be planted in the field instead of carrying out the practice illustrated in **S** and **T**
- (d) What is the importance of carrying out land reclamation?

SOIL FERTILITY 1 (ORGANIC MANURE)

This topic entails the following:

- **Characteristics of a fertile soil**
- **How soil loses soil fertility**
- **Soil fertility maintenance**
- **Reasons of adding organic matter to soil**
- **Disadvantages of organic manure**
- **Types of organic manure i.e green manure, farm yard manure and compost measure.**

The following relevant questions and their answers in this topic will greatly help the user to comprehend and understand the required concepts and practices:

1. State **two** roles of humus in the soil that are beneficial to crops
2. List **four** characteristic of fertile soil
3. The diagram below illustrates a compost heap. Study it and answer the questions that follow
 - a) Name the part labeled **Q** and state its function
 - b) What is the function of each of the following components in preparation of compost manure
 - i) Top soil
 - ii) Wood ash
 - iii) Rotten manure
4. The illustration below shows a four heap system of making compost manure. Study it and answer the questions that follow.
 - (a) By use of arrows indicate on the diagram above how the following material should be transferred from one heap to another till the manure is applied in the field
 - (b) How long does the material take to be ready for application in the field as manure?
 - (c) Give a reason for turning the material in the heap regularly
 - (d) Give **two** reasons why it is necessary to sprinkle water on the heap
5. Name **four** indicators of well-decomposed manure
6.
 - (a) State **two** factors that should be considered when siting a compost manure heap
 - (b) When preparing compost manure, explain the importance of each of the following:-
 - (i) Addition of ash
 - (ii) Regular turning of the compost manure

7. What is **leaching**?
8. State **four** advantages of adding organic matter to a sandy soil
9. (a) Describe the preparation of the following farm materials:-
 - (i) Farm yard manure
 - (ii) Hay(b) Explain the factors considered in timely planting of annual crops
10. A ration containing 18% protein is to be made from maize and sunflower cake. Given that maize contains 7% protein, and sunflower seed cake 34% protein. Use Pearson square method to calculate the value of feedstuffs to be used to prepare 100kgs of the feed
 - ii) A part from Pearson square method, name **two** other methods that can be used to formulate feed ration

LIVESTOCK PRODUCTION I

COMMON LIVESTOCK BREEDS

This topic entails the following:

- **Reasons of keeping livestock**
- **Parts of a cow**
- **Characteristics of indigenous and exotic cattle breeds**
- **Dairy cattle breeds**
- **Beef cattle breeds**
- **Dual purpose cattle breeds**
- **Pig breeds**
- **Sheep breeds**
- **Goat breeds**
- **Rabbit breeds**
- **Camel breeds**

The following relevant questions and their answers in this topic will greatly help and motivate the user to comprehend and understand the required concepts and practices:

1. State **two** reasons for treating water for use on the farm
2. State **four** advantages of applying lime in clay soil
3. State **four** ways by which Re-afforestation help in land reclamation
4. Give **two** distinguishing features between the following breeds of rabbits; Kenya white and California white
5. Give **four** reasons why most farmers keep livestock in Kenya
6. Give **three** ideal conformation features of beef cattle
7. (i) Name a dual purpose cattle breed reared in Kenya
ii) State **three** uses of a rotavator
8. Name a pig breed with the following features:
White body colour, erect ears, dished snout, big in body size
9. What does the term '**epistasis**' mean in livestock improvement?
10. (a) Explain the role of livestock industry in Kenya's economy
(b) Outline the general characteristics of indigenous cattle

11. Below is a diagram of a cattle. Study it and answer the questions that follow:-

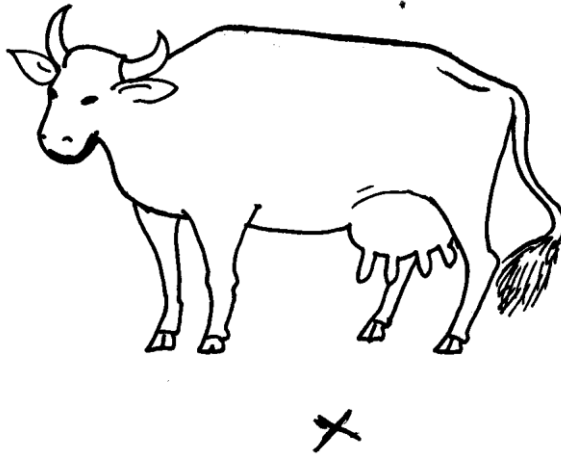

- (i) What type of animal is represented above?
- (ii) If you stand at a point marked **X**, state **five** characteristics that tells you that the animal belong to type name in **(i)** above?
- (iii) State **three** areas on the body of a cow where ticks are commonly found
12. Name **four** breeds of dairy goats
13. List **two** distinguishing characteristics of Californian breed of rabbit
14. Name the common milk breed of goats reared in Kenya
15. Name **four** dairy cattle breeds reared in Kenya.
16. Differentiate between 'breed' of animal and 'type' of animal.
17. Name the camel breed that is adapted to cooler regions and has a woolly body covering
18. State any **two** channels through which beef is marketed in Kenya

AGRICULTURE ECONOMICS

(BASIC CONCEPTS AND FARM RECORDS)

This topic entails the following

- **Definition of scarcity, preference and classic, opportunity cost as used in agriculture production.**
- **Uses of farm records**
- **Types of farm records i.e production records, field operation records, breeding records, feeding records, health, labour records and master roll.**

The following relevant questions and their answers in this topic will greatly help and motivate the user comprehend and understand the concepts and practices.

1. (a) What are the uses of farm records to a farmer?
2. Identify the farm record below and the questions that follow:

Date	Disease symptoms	Animals affected	Drug used	Cost of treatment	Remarks

- (a) Identity of the record
- (b) State **two** different information that should be entered in the remarks column
- (c) Give **two** importance of keeping the farm record illustrated above
3. State **four** uses of farm records
4. State **four** uses of farm records
5. Outline **two** ways the level of education and technology influence the efficiency of agricultural production
6. Study the illustration below of farm records:- Use it to answer the questions that follow:
Enterprise
Month

Name of cow	DAYS IN MONTH											
	1		2		3		4		5		6	
	A	PM	AM	PM	AM	PM	AM	PM	AM	PM	A	PM
	M										M	

- (a) Name the type of the farm record illustrated above

(b) Give **three** reasons for keeping health records in a livestock production

(c) Give **three** pieces of information a dairy farm manager should collect for planning purposes

7. List down four pieces of information recorded in a field operation record.
8. List **two** events occur during induction stroke in a four stroke engine
9. Give **two** conditions under which a farmer may prefer the use of donkey trailed cart instead of a tractor drawn trailer in his farm

FOR THE FOLLOWING;

- ✓ **ONLINE TUITION**
- ✓ **REVISION NOTES**
- ✓ **SCHEMES OF WORK**
- ✓ **SETBOOKS VIDEOS**
- ✓ **TERMLY EXAMS**
- ✓ **QUICK REVISION KITS**
- ✓ **KCSE TOPICALS**
- ✓ **KCSE PREMOCKS**
- ✓ **TOP SCHOOLS PREMOCKS**
- ✓ **JOINT PREMOCKS**
- ✓ **KCSE MOCKS**
- ✓ **TOP SCHOOLS MOCKS**
- ✓ **JOINT MOCKS**
- ✓ **KCSE POSTMOCKS**
- ✓ **TOP SCHOOLS PREDICTIONS**
- ✓ **KCSE PREDICTIONS**
- ✓ **KCSE REVEALED SETS**

CALL/TEXT 0746 222 000

mwalimuconsultancy@gmail.com

**THIS IS A PROPERTY OF MWALIMU
CONSULTANCY LTD.**

**POWERED BY MR
ISABOKE**

SUCCESS