

PHYSICS NOTES

FORM 1 SIMPLIFIED VERSION

QUICK REVISION GUIDE

*An Updated Well-Organized Detailed Learning Notes for the
Current Form 1 Syllabus.*

**A Comprehensive Summary Analysis of
Physics Education Work.**

SERIES 1

Past KCSE Topical Questions Available At The End Of This Book.

Mr Isaboke 0746 222 000

MWALIMU CONSULTANCY

Copyright ©Mwalimu

All rights reserved. This book or any portion thereof may not be reproduced or used in any manner whatsoever without the express written permission of the publisher except for the use of brief quotations in a book review.

Printed in Kenya

00100

Nairobi

0746-222-000

mwalimuconsultancy@gmail.com

Mwalimu Consultancy Ltd.

PHYSICS AS A SCIENCE

- ❖ Physics is a branch of science
- ❖ Science is divided into 3 main branches:-
 - a) Physics
 - b) Chemistry
 - c) Biology

Definition of Physics

- ❖ Physics is defined as the study of matter and it's relation to energy.
- ❖ It involves explaining phenomena such as:
 - I. The falling of bodies towards the ground,
 - II. Rising up of liquids through a drinking straw,
 - III. Seasonal occurrence of tides,
 - IV. A plastic pen rubbed against dry fur or hair picks small pieces of paper,
 - V. A crackling sound is heard when a nylon cloth is removed etc.

Study of Physics

The study of physics entails:

- i. Measurements of quantities and collection of data.
- ii. Drawing and testing of hypotheses through experiments and observation.
- iii. Establishment of laws and principles

BRANCHES OF PHYSICS

1. **Mechanics**

❖ It deals with the study of motion under the influence of force.

2. **Electricity and magnetism**

❖ It deals with relationship between electric field and magnetic field and their applications in the working of motor, microphones, electro-magnets etc.

3. **Thermodynamics**

❖ It deals with the transformation of heat to and from other forms of energy and the accompanying changes in pressure, volume etc.

4. **Geometric optics**

❖ It deals with the behavior of light as it passes through various media.
 ❖ Properties of light like reflection, refraction etc. are studied in this branch of physics.

5. **Waves**

❖ It deals with propagation of energy through space and effects such as reflection, diffraction of light and sound waves.

6. **Atomic physics**

❖ It is deals with the study of the behavior of particles constituting the nucleus (centre) of the atom and their accompanying energy changes.

Relationship between Physics, Other Subjects and Technology

Physics And Geography

Accurate use of weather instruments like thermometer, wind vane, rain gauges etc. require physics knowledge. Concepts like heat transfer by convection which explain the formation of convectional rainfall and pressure variation can be best explained in physics.

Physics and Mathematics

Many concepts in physics like laws, effects, principles etc. are expressed mathematically. Mathematical skills are therefore very instrumental in the leaning of physics

Physics and Chemistry

Physics has helped in explaining the nature of particles within atoms and therefore atomic structure of substances.

Atomic structure of different / various substances determine their reactivity (chemical reactions).

Physics and History

Historians use carbon dating to establish ages of fossils and therefore past patterns of earlier life.

This concept of carbon dating is explained better in atomic physics.

Physics and Home Science

Physics knowledge is used in designing and manufacture of kitchen equipment e.g. electric cookers, microwave ovens, and Mechanizing jikos etc.

Physics and Technology

Machines used in the field of medicine such as x-rays, body scanners and lasers are all applications of physics. Manufacture and use of satellites and microwave dishes used in information technology to relay information is based on physics knowledge

Physics knowledge is also used in defense industry in the manufacture and use of most modern and complex machines.

Physics and Biology

Knowledge of lenses studied in physics has led to the manufacture of microscopes used in the study of the cell and diseases.

CAREER OPPORTUNITIES IN PHYSICS

- ✓ A career refers to a job or a profession that one has been trained for and intends to do for a long period of time e.g. teaching career, medicine, engineering, electrical technician etc.
- ✓ A course refers to lessons in particular subject
- ✓ An occupation refers to a job or a profession.

Examples of courses offered at university level (degrees) that require physics knowledge

- (a) Bachelor of education (science)
- (b) Bachelor of Science (civil engineering)
- (c) Bachelor of medicine
- (d) Bachelor of architecture
- (e) Bachelor of technology (production engineering)

Examples of courses offered at college level that require physics knowledge

- (a) Diploma in civil engineering
- (b) Diploma in computer science
- (c) Diploma in water technology
- (d) Diploma in laboratory technology

THE LABORATORY

❖ A **laboratory** is a special room designed and equipped conducting experiments and practical.

Major systems of the Laboratory

- Gas piping system
- Electrical energy supply system
- Water system

Basic Laboratory Rules

❖ For **safety purposes**, the following laboratory rules **must be followed and observed** while in the laboratory:

1. Locations of electrical switches, firefighting equipment, first aid kit, gas supply and water supply systems must be noted.
2. Windows and doors should be kept open while working in the laboratory.
3. Any instructions given must be followed carefully. NEVER attempt anything while in doubt.
4. There should no eating, drinking or chewing in the laboratory.
5. Ensure that all electrical switches, gas and water taps are turned off when not in use.
6. When handling electrical apparatus, hands must be dry.
7. Never plug in foreign materials into electrical sockets.
8. Shirts and blouses must be tucked in and long hair tied up.
9. Keep floors and working surfaces dry. Any spillage should be wiped off immediately.
10. All apparatus must be cleaned and returned to correct location of storage after use.
11. Laboratory equipment should not be taken out of laboratory unless authorized.
12. Any waste after an experiment must be disposed of immediately.
13. Hands must be washed before leaving the laboratory

FIRST AID MEASURES

<i>Accident</i>	<i>Possible Cause of the Accident</i>	<i>First Aid Measures</i>
<i>Cuts</i>	❖ Poor handling of glass apparatus and cutting tools i.e. scalpels and razors	❖ Seek assistance to stop bleeding ❖ Immediate dressing of the wound
<i>burns</i>	❖ Naked flames ❖ Splashes of concentrated acids and bases	❖ In case of a burn caused by an acid or a base, quickly run cold water over the affected part as you seek for further treatment
<i>Poisoning</i>	❖ Inhaling poisonous fumes ❖ Accidental swallowing of poisonous chemicals	❖ Seeking immediate assistance
<i>Eye damage</i>	❖ Bits of solids ❖ Dangerous chemicals	❖ In case of irritating chemicals wash your eyes with a lot of clean water.
<i>Electrical shock</i>	❖ Touching exposed (naked) wires ❖ Using faulty electrical appliances	❖ Put off the main switch first before treating the shock

Revision Exercise

) Name 3 branches of science subject in secondary schools

) Explain the steps involved in scientific approach.

) Name and briefly explain the branches of physics

) Give instances where physics interdependent with agriculture.

	<i>Topic</i>	<i>Branch of physics</i>
<u>1</u>	<i>Measurement I</i>	
<u>2</u>	<i>Force</i>	
<u>3</u>	<i>Pressure</i>	
<u>4</u>	<i>Particulate nature of matter</i>	
<u>5</u>	<i>Rectilinear propagation of light and reflection at plane surfaces</i>	
<u>6</u>	<i>Thermal expansion</i>	
<u>7</u>	<i>Heat transfer</i>	
<u>8</u>	<i>Electrostatics</i>	
<u>9</u>	<i>Simple cells and electric circuits</i>	

Chapter Two

MEASUREMENT I

Introduction

- ❖ **Measurement** refers to the process of finding the size of a physical quantity.
- ❖ Scientists all over the world have one international system of units i.e. *systeme internationale de unites* (SI units) for physical quantities.

Reasons for Establishing SI Units

1. To have international uniformity among scientists.
2. To avoid confusion among scientists.

TYPES OF PHYSICAL QUANTITIES

Basic Physical Quantities (Fundamental Physical Quantities)

- ❖ These are quantities that cannot be obtained from other physical quantities.
- ❖ There are seven basic quantities according to the international system of units (SI units). They are as shown in the table below:

<i>Basic physical quantity</i>	<i>SI unit</i>	<i>Symbol of the SI unit</i>
Length	Meter	m
Mass	Kilogram	kg
Time	Second	s
Electric currents	Ampere	A
Thermodynamic temperature	Kelvin	K
Luminous intensity	Candela	Cd
Amount of substance	mole	mol

ii. Derived Physical Quantities

- ❖ These are quantities obtained by *multiplication or division* of other physical quantities e.g. area, volume, work, density, momentum etc.

3. Complete the table below

<i>Basic quantity</i>	<i>SI unit</i>	<i>Symbol of unit</i>	<i>Derived quantity</i>
<i>Length</i>			
<i>Mass</i>			
<i>Electric current</i>			
<i>Thermodynamic temperature</i>			
<i>Luminous intensity</i>			
<i>Amount of substance</i>			

4. Why is it necessary to establish SI units?

LENGTH

- ❖ It is the measure of distance between two points. Examples of length are:
 - Breadth
 - diameter
 - height
 - Depth etc.

Multiples and Sub-multiples of the metre

- ☐ 1000 m
- ☐ 100 m
- ☐ 10 m
- ☐ 10 decimetre (dm)
- ☐ 100 centimeter (cm)
- ☐ 1 000 millimeter (mm)
- ☐ 1 000 000 micrometer (µm)

Exercise 2.2

Convert the following into SI units

- a) 1000km (answer: 1 000 000 m)
- b) 0.00025 mm (answer: 0.00000025 m)
- c) 0.01Hm (answer: 1 m)
- d) 25 mm (answer: 0.025 m)
- e) 25 µm (answer: 0.000025 m)

Factors Considered When Choosing an Instrument for Measuring Lengths

1. Size of the object to be measured.
2. Level of accuracy required.

The Meter rule

- ❖ Meter rules and a half-meter rules are graduated (calibrated) in *centimeter* and *millimeter*
- ❖ The *smallest division on a meter rule* scale is *1mm (0.1cm or 0.001 m)*. This is the *accuracy* of the meter rule.

Note:

- **Accuracy of a measuring instrument** is the smallest value that can be accurately obtained using the instrument.
- The measurement taken using a measuring instrument **must** be expressed to the **number of decimal places** of the **accuracy** of that instrument. For example, any measurement taken using a meter rule should be expressed in **whole number if in millimeter, to 1 decimal place if in centimeters** and **to 3 decimal places if in meters**.

Procedure Followed When Using a Meter Rule

1. Place the meter rule in contact with the object whose length is to be measured.
2. Place the end of the object against the zero cm mark of the scale.
3. Position your eye perpendicularly above the scale.

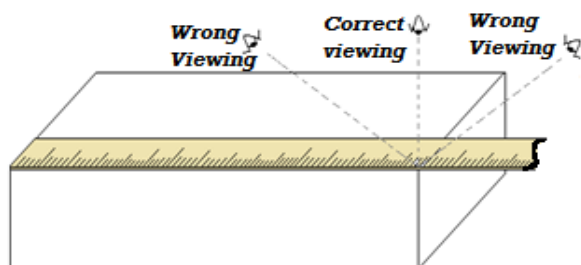

Sources of Error When Using a Meter Rule

- ❖ When using a meter rule, an error may arise when:
 - the rule is not in contact with the object,
 - the end of the object is not aligned to the zero mark of the meter rule scale,
 - the position of the eye is not perpendicular to the scale.
- ❖ **NB: The error that occurs when the position of the eye is not perpendicular to the scale is called *parallax error***

Example

What are the readings indicated by arrows $R_1, R_2, R_3, R_4, R_5, R_6$

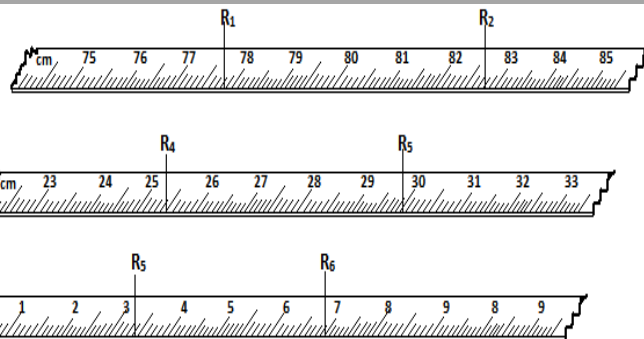

$R_1 = 77.9 \text{ cm}, R_2 = 82.8 \text{ cm}, R_3 = 25.5 \text{ cm}, R_4 = 30.0 \text{ cm}, R_5 = 3.4 \text{ cm}, R_6 = 7.0 \text{ cm}$

Exercise

Express the above readings in:

- I. Mm
- II. M

Precaution When Using a Meter Rule

- ❖ Care should be taken to avoid damage to the ends of meter rules. This is because most of them do not have a short allowance at the ends to cater for wear.

TAPE MEASURE

Types of Tape Measure

- i. Tailor's tape measure
- ii. Carpenter's tape measure
- iii. Surveyor's tape measure etc.

Note: The choice of tape measure depends on the **nature** and **length** of distance to be measured.

Precaution When Using Tape Measure

- ❖ Ensure it is taut (very straight) during use.

Measuring Curved Lengths

- ❖ To measure curved lengths such as rails and roads on maps, a thread is placed along the required length. The length is then found by placing the thread on a millimeter scale.
- ❖ For curved surfaces like a cylinder, a thread is closely wrapped around the surface a number of times.

Experiment 2.1

Aim/ Objective

To measure the circumference of a measuring cylinder using a thread

Apparatus

- i. 10 ml measuring cylinder
- ii. Thread
- iii. Meter rule

Procedure

1. Closely wrap a thin thread ten times around the cylinder as shown below.

3, R 4, R 5 and R 6 below.

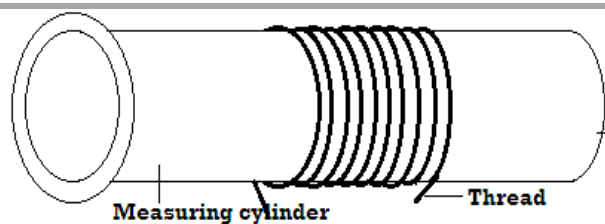

2. Mark with ink the beginning and end of the turns.
3. Remove the thread.
4. Measure the length between the ink marks and call it R_1 .
5. Repeat two times, recording readings as R_2 and R_3 so as to ensure accuracy of your measurements.
6. Find the average length as $\frac{R_1 + R_2 + R_3}{3}$.

Results and Calculations

- ❖ Average length of 10 turns, $R = \frac{R_1 + R_2 + R_3}{3}$
- ❖ Circumference of the cylinder = $\frac{R}{10}$
- ❖ Diameter of the cylinder (D) is obtained as:

$$D = \frac{\text{circumference}}{\pi}$$

Exercise

Theoretical

1. A length 550cm of a thin thread wraps around a cylinder exactly 25 times. Calculate the circumference and the radius of the cylinder. (Take $\pi = \frac{22}{7}$).
2. Philip found that the perimeter of his farming plot was approximately 500 strides. His stride was 1.1 m long. What was the perimeter of the plot?

Experimental

1. Estimate the width of your desk by counting how many of your palm lengths are there
2. Describe a method you can use to estimate the thickness width of one sheet of paper of your book.
3. Describe a method that can be used to estimate the thickness of a razor blade.

Estimation of Length

Experiment 2.2

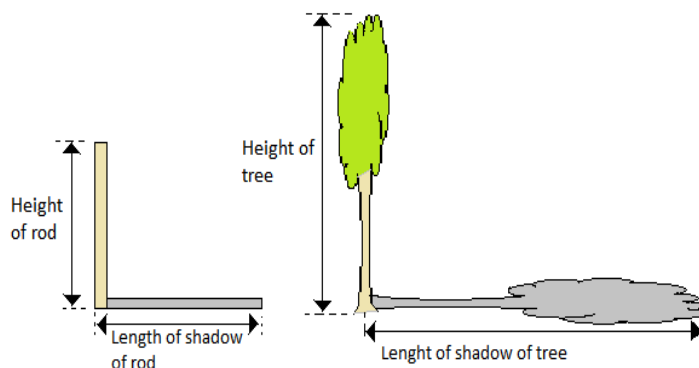

Results and Calculations

- Height of the tree is estimated using the expression:

$$\frac{\text{height of the tree, } h_{\text{tree}}}{\text{height of rod, } h_{\text{rod}}} = \frac{\text{length of shadow of tree, } L_{\text{tree}}}{\text{length of shadow of rod, } L_{\text{rod}}}$$

Example

In an experiment to estimate the height of a tree in Nyabururu Girls' Secondary School compound, Grace recorded the following data.

- I. Length of shadow of the tree = 1000cm
- II. Length of shadow of the rod = 200cm
- III. Height of the rod = 100cm
- IV. Determine the height of the tree

Solution

$$\frac{\text{height of the tree, } x}{\text{height of the rod}} = \frac{\text{length of shadow of tree}}{\text{length of shadow of rod}}$$

$$\frac{x}{100} = \frac{1000}{200}$$

$$x = 5.0\text{m}$$

AREA

- ❖ Area refers to the measure of surface.
- ❖ The SI unit of area is the square meter (m^2).

Multiples and sub-multiples of the square metre

- I. $1 \text{ m}^2 = 1000 \text{ 000 mm}^2$
 - II. $1 \text{ m}^2 = 10 \text{ 000 cm}^2$
 - III. $1 \text{ km}^2 = 1000 \text{ 000 m}^2$
- a)

Exercise

Aim /objective: To estimate the height of a tree

Apparatus

- A rod of length 2 meters
- A meter rule.

Procedure

1. Hold the rod upright and measure its length.
2. Measure the length of its shadow.
3. Measure the length of the shadow of a tree in the school compound.

1. Express the following in square centimeter

- a) 0.00027 km²
- b) 4.5 m²

2. Express the following in SI units

- a) 9000 cm²
- b) 0.009 cm²
- c) 25 km²

Measurement of Area

Area of Regularly –Shaped Objects

❖ Area of irregular-shaped objects is obtained using appropriate formulae.

A. Rectangle

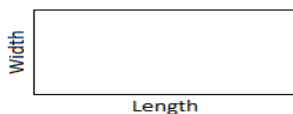

Area = length × width

B. Circle

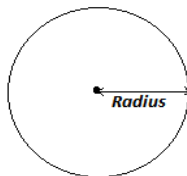

Area = πr², where r = radius

C. Triangle

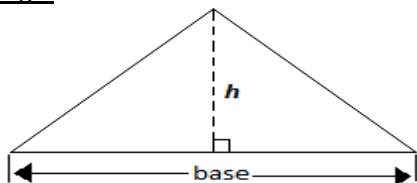

Area = 1/2 (base × perpendicular height)

D. Trapezium

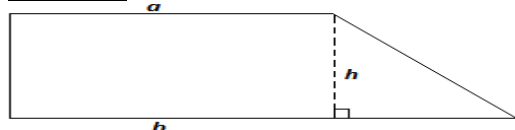

Area = 1/2 (sum of parallel sides) × height

Area of Irregularly-Shaped Surfaces

❖ Area of irregularly shaped surface can be estimated by sub-dividing the surface into small equal squares and the area obtained as:

Area

= (number of complete squares + 1/2 × number of incomplete squares) area of one square

Example

Estimate the area of the irregular surface shown in the figure below by counting the small squares. The area of one complete square is 1cm².

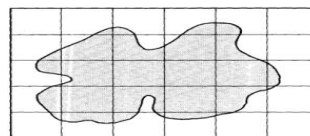

Solution

- Area = (number of complete squares + 1/2 × number of incomplete squares) area of one square
- Area = (4 + 1/2 × 22) × 1 cm²
- Area = 15 cm²

Exercise

- 1) Trace the outline of your palm on a graph paper and estimate the area of the shape obtained.
- 2) Determine the area of the top of your desk.
- 3) The diameter of the bore of a capillary tube is 2.0mm. Calculate the cross-section area of the bore in cm² (take π=3.142)
- 4) A sheet of paper measures 25cm by 15cm. Calculate its area in mm²

Volume

- ❖ Volume refers to the amount of space occupied by matter.
- ❖ It is a derived quantity of length.
- ❖ The SI unit of volume is **the cubic meter (m³)**

Multiples and Sub- Multiples of the Cubic Metre

- (a) 1m³ = 1000000 cm³
- (b) 1m³ = 1000 000 000 mm³
- (c) 1km³ = 1000 000 000 m³
- (d) 1m³ = 1000 liters
- (e) 1 liter = 1000ml
- (f) 1l = 1dm³

Exercise

Convert each of the following volumes to SI unit

- I. 1500 000 000 cm³
- II. 20.0 liters
- III. 1.0 ml
- IV. 9000 000 000 mm³
- V. 1000 000 l

Volume of Regular – Shaped Solids

❖ Volume of regularly – shaped solids is obtained by applying an appropriate formula.

1. CUBOID

Volume = cross-section area x height

$$\text{Volume} = \text{length} \times \text{breadth} \times \text{height}$$

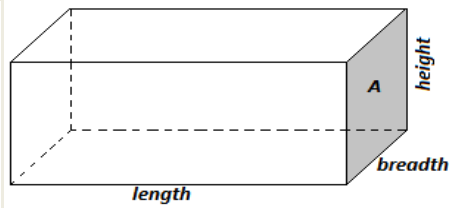

2. Triangular prism

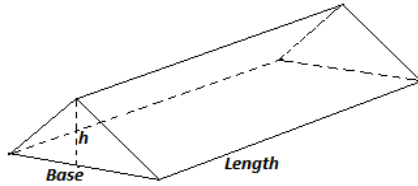

Volume = cross-section area x length

$$\text{Volume} = \frac{1}{2} \text{base} \times \text{height} \times \text{length}$$

3. cylinder

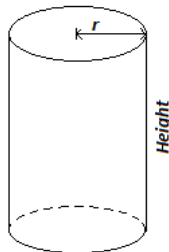

Volume = cross section area x height

$$\text{Volume} = \pi r^2 h$$

4. Sphere e.g. foot ball

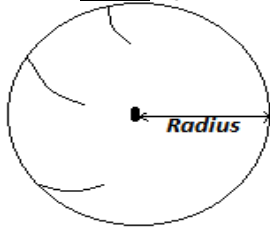

$$\text{volume} = \frac{4}{3} \pi r^3$$

5. Cone

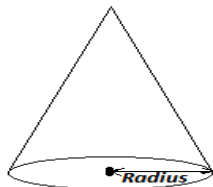

$$\text{volume} = \frac{1}{3} \pi r^2 h$$

Examples

1) A rim of foolscaps contains 500 papers and has a mass of 2kg. The size is 300mm by 200mm by 50mm. find:

I. The thickness of one sheet of paper.

$$\frac{200\text{mm}}{500 \text{ papers}} = 0.4\text{mm}$$

$$= 0.0004 \text{ m}$$

II. The mass of one sheet of paper.

o 500 papers = 2kg

▪ mass of 1 paper = $\frac{2\text{kg}}{500}$

o = 0.004kg

III. The volume of the rim.

o volume = $L \times W \times h$

o 300 mm x 200 mm x 50 mm

$$= 3\,000\,000 \text{ mm}^3$$

$$= 0.003 \text{ m}^3$$

IV. The volume of one sheet of paper

Volume of 500 papers = 0.003 m³

o volume of 1 paper = $\frac{0.003 \text{ m}^3}{500}$

$$= 0.000006 \text{ m}^3$$

2) A block of glass is 50cm long, 4.0cm thick and 2.5cm high. Calculate its volume

volume of the glass block = length x breadth x height

$$= 5.0 \text{ cm} \times 4.0 \text{ cm} \times 2.5 \text{ cm}$$

$$= 50\text{cm}^2$$

$$= 0.000050 \text{ m}^3$$

3) Find the volume of the cylindrical tin of radius 7.0cm and height 3.0cm.

$$\text{volume of tin} = \pi r^2$$

$$= \frac{22}{7} \times 7 \text{ cm} \times 7 \text{ cm} \times 3 \text{ cm}$$

$$= 462.0\text{cm}^3$$

$$= 0.0004620 \text{ m}^3$$

4) Find the volume of a triangular prism if base = 6.0cm, height = 5.0cm and length = 12.0cm

volume = area of cross-section x length

$$= \left(\frac{1}{2} \times 6.0 \text{ cm} \times 5.0 \text{ cm}\right) \times 12.0 \text{ cm}$$

$$= 180.0 \text{ cm}^3$$

$$= 0.0001800 \text{ m}^3$$

5) Find the volume of a sphere whose radius is 3.0cm

$$\text{volume of sphere} = \frac{4}{3} \pi r^3$$

$$= \frac{4}{3} \times \frac{22}{7} \times 3.0 \text{ cm} \times 3.0 \text{ cm} \times 3.0 \text{ cm}$$

$$= 113.14 \text{ cm}^3$$

$$= 0.00011314 \text{ m}^3$$

6) A sphere of diameter 6.0 mm is molded into a uniform wire of diameter 0.2mm. Calculate the length of the wire. (take $\pi = \frac{22}{7}$)

volume of sphere = volume of wire

$$\frac{4}{3} \pi R^3 = \pi r^2 l$$

$$\frac{4}{3} \times \frac{22}{7} \times 3.0 \text{ mm} \times 3.0 \text{ mm} \times 3.0 \text{ mm} = \frac{22}{7} \times 0.1 \text{ mm} \times 0.1 \text{ mm} \times l$$

$$36 \text{ mm}^3 = 0.01 \text{ mm}^2 l$$

$$l = \frac{36 \text{ mm}^3}{0.01 \text{ mm}^2} = 3600 \text{ mm} = 3.6 \text{ 00 ml}$$

Measurement of Volume of Liquids

Using a Container with Uniform Cross-Section Area.

❖ The liquid is poured into the container and the height of the liquid in the container is measured. The volume of the liquid is calculated using the expression:

$$\begin{aligned} \text{Volume of liquid} \\ &= \text{cross section area of container} \\ &\times \text{height of liquid} \end{aligned}$$

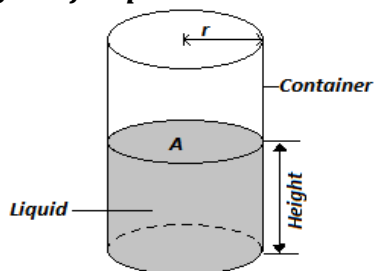

Using a suitable volume measuring apparatus

❖ The following apparatus are used to measure volume accurately of liquids in laboratory:

- a) Pipette
- b) Burette
- c) Volumetric flask
- d) Syringe

❖ Pipette and volumetric flask measure fixed volumes of liquids.

❖ The following apparatus are used to approximately measure volume of liquids in laboratory:

- a) Measuring cylinders
- b) Graduated beakers
- c) Conical flasks

The Burette



The scale of the burette is marked such that zero cm³ mark is at the top and the maximum value mark at the bottom.

Example

Water level in a burette is 24 cm³. If 100 drops of water fall from the burette and the average volume of one drop is 0.12 cm³. What is the final water level in the burette?

Solution

$$\begin{aligned} \text{Volume of 1 drop} &= 0.12 \text{ cm}^3 \\ \text{volume of 100 drops} &= 1000 \times 0.12 \text{ cm}^3 \\ &= 12 \text{ cm}^3 \\ \text{initial level} &= 24 \text{ cm}^3 \\ \text{final level} &= (24 + 12) \text{ cm}^3 \\ &= 36 \text{ cm}^3 \end{aligned}$$

Note:

❖ When using a measuring vessel the reading of the volume is taken with the eye positioned in level with the bottom of the meniscus (for liquids which curve upwards) as in (a) or top of the meniscus (for liquids which curve downwards) as in (b) below.

Measuring Volume of Irregular- Shaped Solids

❖ The method used in this case is called displacement method since the solid displaces some liquid when immersed.

Conditions under which displacement method works:

For displacement method to work best, the solid whose volume is to be determined should:

- (a) not be soluble in the liquid being used,
- (b) not react with the liquid,
- (c) sink in the liquid and,
- (d) not absorb the liquid.

Experiments

Aim: To measure volume of irregularly – shaped solid

Requirements: stone, thread, measuring cylinder, water, Eureka can (also called displacement or overflow can), floater and a sinker.

Method 1: Using measuring cylinder

Procedure

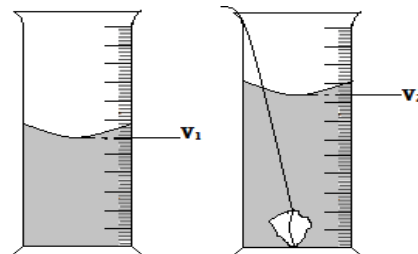

1. Partly fill the measuring cylinder with water and note the volume V₁ of the water
2. Tie the stone with a thread and lower it gently in the cylinder until it is fully submerged
3. Note the new volume of water V₂

Results and calculations

The volume of the stone can be calculated as:

$$\text{volume} = V_2 - V_1$$

Method 2: Using Eureka can

Procedure

1. Fill Eureka can with water until it overflows
2. Wait for the water to stop coming out of the spout
3. Place a measuring cylinder under the spout
4. Tie the stone with a thread and lower it gently into water until it is fully submerged
5. Collect the water coming out of the spout using a measuring cylinder.

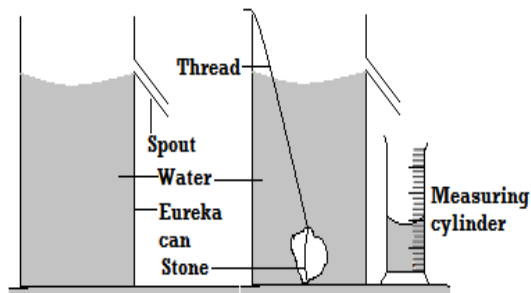

Results and calculations

The volume of water collected in the measuring cylinder is the volume of the stone.

Method 3: Measuring volume of an irregular-shaped floater using Eureka can

Procedure

1. Fill the Eureka can with water until it overflows
2. Wait for the water to stop coming out of the spout
3. Lower the sinker tied with a thread gently into the can
4. Measure the volume V_1 that flows into the measuring cylinder
5. Remove the sinker and tie it to the cork as you fill Eureka can again and allow it to overflow. Then place the measuring cylinder under the spout.
6. Lower the sinker and cork tied together gently and measure V_2 that overflows into the measuring cylinder.

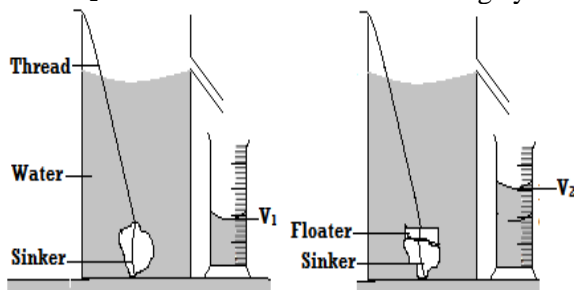

Results and calculations

The volume of the stone can be calculated as: **Volume** = $V_2 - V_1$

Example

- 1) Determine the volume of water in the cylinder shown below.

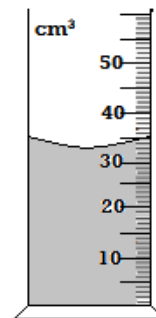

Solution:

$$\text{Volume} = 33 \text{ cm}^3$$

(Remember that accuracy of the scale shown above is 1 cm^3)

- 2) If a stone of volume 6 cm^3 is inserted to sink in water in the above cylinder what will be the new water level?

Solution

$$\text{New level} = \text{initial level} + \text{volume of stone}$$

$$\begin{aligned} \text{New level} &= 33 \text{ cm}^3 + 6 \text{ cm}^3 \\ &= 39 \text{ cm}^3 \end{aligned}$$

Mass

- ❖ Mass is the quantity of matter in an object.
- ❖ The **SI unit** of mass is **the kilogram (kg)**.

Multiples and Submultiples of the kilogram

- ❖ $1 \text{ kg} = 1000 \text{ g}$
- ❖ $1 \text{ tonne} = 1000 \text{ kg}$
- ❖ $1 \text{ g} = 1000 \text{ mg}$
- ❖ $1 \text{ kg} = 1000000 \text{ mg}$
- ❖ $1 \text{ tonne} = 1000000 \text{ g}$

1.

Exercise

2. Convert 39.6 mg into **kg** (answer: **0.0000396 kg**)
3. Change **50 tonnes** into **g** (answer: **50000000 g**)
4. **340 kg** into **tonnes** (answer: **0.340 tonnes**)
5. **20 g** into **kg** (answer: **0.020 kg**)
6. **100 g** into **kg** (answer : **0.100 kg**)

Measurement of Mass

- ❖ There are three instruments that can be used used:
 - Top pan balance (electrical type)
 - Beam balance (mechanical type)
 - Lever balance (mechanical type)

Advantages of Electrical Balance (Top Pan Balance) Over the Beam Balance (Mechanical Type)

1. Electrical balance is accurate.
2. It is easy to use than beam balance.

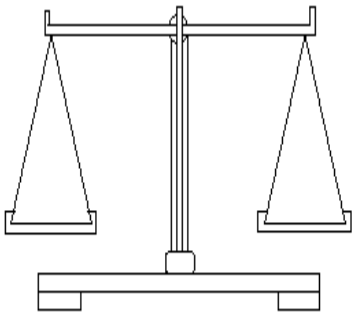

Beam balance

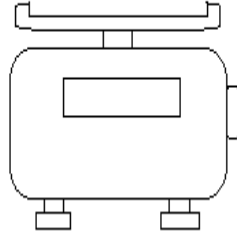

Electronic top pan balance

Density

❖ It is defined as the mass per unit volume of a substance.

❖ Density is denoted by a Greek letter **rho** (ρ)

$$\text{Density} = \frac{\text{mass}}{\text{volume}}$$

$$\rho = \frac{m}{v}; v = \frac{m}{\rho}; m = \rho \times v$$

❖ Since mass is measured in kg and volume in m^3 then the **SI unit** of density is **the kilogram per cubic meter** (kg/m^3 or kgm^{-3})

$$1g/cm^3 = 1000kg/m^3$$

Examples

3. Show that $1g/cm^3 = 1000kg/m^3$

$$\begin{aligned} g/cm^3 &= \frac{1g}{1cm^3} \\ &= \frac{0.001 kg}{0.000001 m^3} \\ &= 1000 kg/m^3 \end{aligned}$$

4. Determine the density in kg/m^3 of a solid whose mass is 40g and whose dimensions in cm are $30 \times 40 \times 3$

$$\begin{aligned} V &= L \times W \times h \\ V &= 30 \times 3 \times 4 = 360cm^3 \\ \rho &= \frac{m}{v} \end{aligned}$$

$$\frac{40g}{360cm^3} = 0.11111 gcm^{-3}$$

$$1g1cm^3 = 1000kg1m^3$$

$$0.1111 g1cm^3 = \frac{0.1111 g/cm^3 \times 1000kg1m^3}{1gcm^3}$$

$$= 111.1 kg/m^3$$

5. A wooden block of mass 200g is 4.0 cm wide 3.0 cm thick and 6.0 cm long. Calculate the density of the wooden block in kg/m^3

$$\begin{aligned} V &= L \times W \times h \\ &= 6 cm \times 4 cm \times 3 cm \\ V &= 72 cm^3 \end{aligned}$$

$$\rho = \frac{m}{v}; \frac{200g}{72cm^3} = 2.7777 g/cm^3$$

$$1g/cm^3 = 1000kg/m^3$$

$$\begin{aligned} 2.7777 g/cm^3 &= 2.777 \times 1000 kg/m^3 \\ &= 2778kg/m^3 \end{aligned}$$

1. The density of a substance is $15g/cm^3$. Express this in SI units

$$1g1cm^3 = 1000kg1m^3$$

$$\begin{aligned} 15g1cm^3 &= \frac{15g/cm^3 \times 1000kg1m^3}{1gcm^3} \\ &= 15000kg/m^3 \end{aligned}$$

2. The figure alongside shows a measuring cylinder which contains water initially at level A. When a solid of mass 11g is immersed in water the level raises to B. Determine the density of the solid.

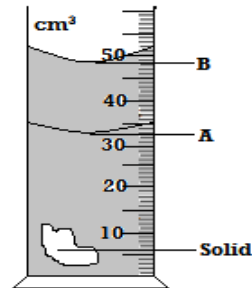

$$\begin{aligned} \text{Volume of solid} &= V_B - V_A \\ 48 cm^3 - 33 cm^3 &= 15 cm^3 \end{aligned}$$

$$\rho = \frac{m}{v}$$

$$\begin{aligned} &= \frac{30 g}{15 cm^3} = 2.000 \frac{g}{cm^3} \\ &= 2000 kg/m^3 \end{aligned}$$

Exercise

1. The diagram below shows the change in volume of water in a measuring cylinder when an irregular solid is immersed in it.

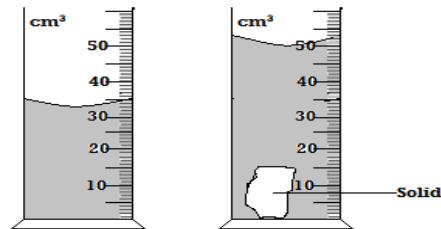

Given that the mass of the solid is 56.7g determine the density of the solid in g/cm^3 (give answer correct to 2 decimal places)

2. Complete the table

mass	volume	Density
0.012kg	20cm ³	0.6g1cm ³
200gcm ³	800kg1m ³
.....tonne	125m ³g1cm ³
s		

Density Bottle

- ❖ It is a small glass bottle fitted with glass stopper (made of ground glass) which has a hole through which excess liquid flows out.

Precautions When Using a Density Bottle

1. The bottle should be held by the neck when wiping it. This is to prevent it from expanding due to body warmth when held by sides by using hands.
2. The outside of the bottle must be wiped dry carefully.
3. There should be no air bubbles when the bottle is filled with liquid.

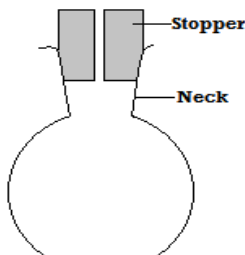

N/B Density bottle is used measure the density of either liquid or solid.

Examples

1. The mass of a density bottle is 20.0g when empty, 70.0g when full of water and 55.0g when full of a second liquid x. Calculate the density of the liquid (take density of water to be 1g/cm³)

Solution

- ✓ Mass of empty density bottle = 20.0g
- ✓ Mass of density bottle + wat = 70.0g
- ✓ Mass of water in density bottl = 50.0g
- ✓ Volume of density bottle = $\frac{m}{\rho} = \frac{50.0\text{ g}}{1\text{g/cm}^3} = 50\text{cm}^3$
- ✓ Mass of density bottle + liquid = 55.0g
- ✓ Mass of liquid filling the bottle = 55.0 – 20.0 = 35.0g
- ✓ Volume of liquid = volume of density bottle = 50 cm³
- ✓ ρ of liquid x = $\frac{m}{v} = \frac{35.0}{50} = \frac{0.7\text{g}}{\text{cm}^3} = 700\text{kg/m}^3$

2. In an experiment to determine the density of a certain solid D, the following readings were obtained using a density bottle

- a) Mass of empty density bottle = 8g
- b) Mass of a density bottle and solid D = 96g
- c) Mass of density bottle + 30g water + solid D = 132g
- d) Mass of density bottle + water = 88 g

Calculate

- vii) Mass of water in density bottle in part d).

$$88\text{ g} - 8\text{ g} = 80\text{ g}$$

$$= 0.080\text{ kg}$$

- viii) Volume of water in d) (take density of water be 1000kg/m³).

$$V = \frac{m}{\rho}$$

$$= \frac{0.080\text{ kg}}{1000\text{kg/m}^3}$$

$$= 0.00008\text{ m}^3$$

- i) **Volume of the density bottle**
Volume of the density bottle = Volume of water filling it.
Volume of the density bottle = 0.000008 m³

- ii) **Mass of solid D in part b)**

- iii) 96 – 8g
= 48g
= 0.088 kg

- iv) **Density of solid D**

$$\rho = \frac{m}{v}$$

$$= \frac{0.088\text{ kg}}{0.00008\text{ m}^3}$$

$$= 1100\text{ kg/m}^3$$

- v) **Volume of water in c)**

$$V = \frac{m}{\rho}$$

$$= \frac{0.030\text{ kg}}{1000\text{ kg/m}^3}$$

$$= 0.000030\text{ m}^3$$

- vi) **Mass of solid D in d).**

$$m = \rho \times v$$

$$m = 1100 \times (0.000080 - 0.000030)$$

$$m = 0.055\text{ k}$$

Exercise

A density bottle has a mass of 17.5g when empty. When full of water its mass is 37.5g. When full of liquid x its mass is 35 g. If the density of water is 1000kg/m³, find the density of liquid x.

Density of Mixtures

- ❖ A **mixture** is obtained by putting two or more substance such that they do not react with one another.
- ❖ The density of the mixture lies between the densities of its constituent substances and depends on their proportions.

$$\text{Density of mixture} = \frac{\text{Total mass of the mixture}}{\text{Total volume of mixture}}$$

Example

1. A mixture consists of 40cm³ of water and 60cm³ of liquid X. if the densities of water and liquid X are 1.0g/cm³ and 0.8g/cm³ respectively, calculate the density of the mixture.

$$\text{Mass of water} = \rho_w \times V_w$$

$$= 1.0\text{g/cm}^3 \times 40\text{cm}^3$$

$$= 40\text{ g}$$

$$\text{mass of liquid x} = \rho_x \times V_x$$

$$= 0.8\text{ g/cm}^3 \times 60\text{cm}^3 = 48\text{ g}$$

Density of mixture

$$= \frac{\text{mass of water} + \text{mass of liquid X}}{\text{volume of water} + \text{volume of liquid X}}$$

$$\text{Density of mixture} = \frac{40 \text{ g} + 48 \text{ g}}{40 \text{ cm}^3 + 60 \text{ cm}^3}$$

$$\text{Density of mixture} = \frac{88 \text{ g}}{100 \text{ cm}^3} = 0.880 \text{ g/cm}^3$$

2. A solution contains 40cm^3 by volume of alcohol and 60cm^3 water. If the density of the alcohol is 0.79g/cm^3 and water is 1.0g/cm^3 . Calculate the density of the solution.

$$\begin{aligned} \text{mass of water} &= \rho_w \times V_w \\ &= 1\text{g/cm}^3 \times 60\text{cm}^3 = 60\text{g} \end{aligned}$$

$$\begin{aligned} \text{mass of alcohol} &= \rho_a \times V_a \\ &= 0.79 \text{ g/cm}^3 \times 40\text{cm}^3 = 31.6\text{g} \end{aligned}$$

$$\begin{aligned} \text{Density of mixture} &= \frac{\text{mass of water} + \text{mass of alcohol}}{\text{volume of water} + \text{volume of alcohol}} \end{aligned}$$

$$\begin{aligned} \text{Density of mixture} &= \frac{60 \text{ g} + 31.6 \text{ g}}{60 \text{ cm}^3 + 40 \text{ cm}^3} = \frac{91.6 \text{ g}}{100 \text{ cm}^3} \\ &= 0.916 \text{ g/cm}^3 \end{aligned}$$

Time

- ❖ Time is the measure of duration.
- ❖ SI unit is **the second (s)**.

Multiples and sub- multiples of second

- ☐ 1minute = 60second
- ☐ 1hour = 3600 second
- ☐ 1day = 24 hours = 86400 second
- ☐ 1second = 100 cent – second
- ☐ 1second = 1000 millisecond (ms)
- ☐ 1second = 1000 000 microsecond (μs)

Measurement of Time

- ❖ Time is measured using either the stop watch or a stop clock depending on level of accuracy required.

Advantages of Stop Watch Over Stop Clock

- 1.) Stop watch is easy to handle and read than stop clock.
- 2.) It is more accurate than stop clock.

Example

Express the time shown on the stop watch screen below in SI.

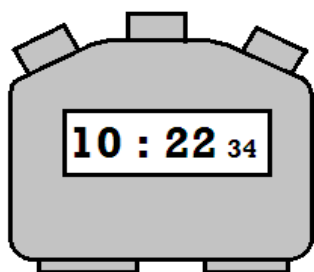

$$\begin{aligned} &= 10 \times 60 + 22 + 34 \times 0.01 \\ &= 600 + 22 + 0.34 = 622.343 \text{ seconds} \end{aligned}$$

Simple Pendulum

- ❖ It is a device that can be used to determine time intervals.
- ❖ It makes oscillations when displaced slightly.
- ❖ An **oscillation** is a complete to and fro motion.

Experiment

Aim: To determine time taken to complete given oscillations

Apparatus: Pendulum bob, thread, stop watch, clamp, boss and retort stand.

Procedure

- i) Set your apparatus as shown below.

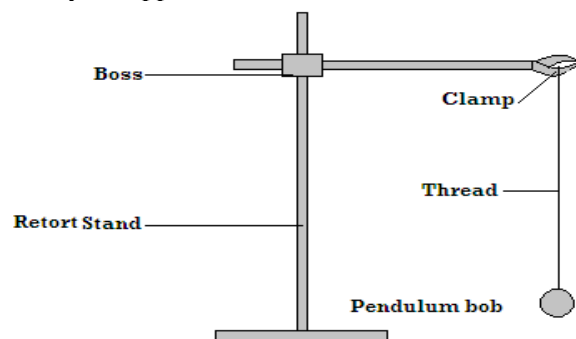

- i) Slightly displace the bob and determine the time taken to make 3 oscillations
- ii) Repeat the procedure for the following number of oscillations and fill the table below.

No. of oscillations	Time (s)	Time for 1 oscillation, T (s)
2		
4		
6		
8		

Calculations

Time for 1 oscillation can be calculated as:

$$T = \frac{\text{Time for } n \text{ oscillations}}{n}$$

Revision Exercise

1) Identify the mistake in the following SI units and hence write them correctly.

- (a) Amperes(a)
- (b) Candela(cand)
- (c) Metres(M)
- (d) Kelvin
- (e) Seconds
- (f) Kilograms
- (g) Pascals
- (h) newtons

2) convert the following into derived SI units

- (a) 0.01cm
- (b) 100cm²
- (c) 20days
- (d) 3.625g
- (e) 324tonnes
- (f) 5dm³
- (g) 400ml

3) Estimate the length of the curve shown.

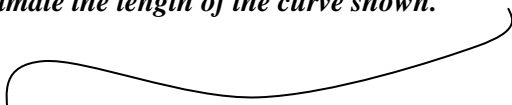

4) Define density and give its SI units.

5) A burette shows a liquid level as 20cm^3 . Ten drops of the same liquid each of volume 0.5cm^3 are added. Calculate the new liquid level.

6) An empty density bottle has a mass of 15g. When full of alcohol of density 0.8g/cm^3 , its mass is 47g. Calculate:-

i) The volume of the bottle.

ii) Its mass when full of water.

iii) Its mass when full of mercury of density 13.6g/cm^3 .

7) A measuring cylinder contains 8cm^3 of water. A small piece of brass of mass 24g is lowered carefully into a measuring cylinder so that it is carefully submerged, if the density of the brass is 8g/cm^3 , what is the new reading of the level of water in the cylinder in m^3 .

8) A Eureka can of mass 60g and cross sectional area of 60cm^2 is filled with water of density 1g/cm^3 . A piece of steel of mass 20g and density 8g/cm^3 is lowered carefully into the can as shown

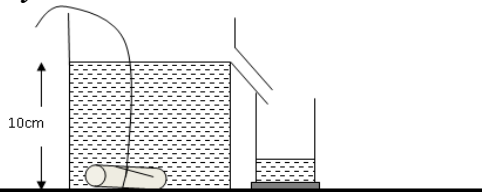

Calculate;

a) The total mass of water and the Eureka can before the metal was lowered.

b) The volume of water that overflowed.

c) The final mass of the eureka can and its contents

d) In finding the density of liquid, why is the method of using density bottle more accurate than the one of using a measuring cylinder.

9) 25cm^3 of a liquid x of density 1.2g/cm^3 is mixed with liquid of volume 30cm^3 and 0.9g/cm^3 without change in volume. Calculate the density of the mixture.

10) The mass of an empty density bottle is 25.0g. Its mass when filled with water is 50.0g and when filled formalin its mass is 60.0g. Calculate.

a) Mass of water

b) Volume of water.

c) Volume of bottle.

d) Mass of formalin.

e) Volume of formalin.

f) Density of formalin.

11) A butcher has a beam balance and masses 0.5 kg and 2 kg. How would he measure 1.5 kg of meat on the balance at once?

12) Determine the density in kg/m^3 of a solid whose mass is 40g and whose dimensions in cm are $30 \times 4 \times 3$

13) Figure below shows the reading on a burette after 55 drops of a liquid have been used.



If the initial reading was at 0cm mark, determine the volume of one drop.

14. A mixture is made up of two metals X and Y. The mass of the mixture is 30 g and the volume of the mixture is 4.5cm^3 . Determine the mass of metal X in the mixture. (Density of metal X is 6000Kg m^{-3} and density of metal Y is 7900Kg m^{-3})

**This is a Property of Mwalimu
Consultancy Ltd. Contact Mr Isaboke
0746-222-000 for more Educational
Materials.**

Chapter Three

FORCE

DEFINITION OF FORCE

- ❖ Force refers to a push or a pull that result from interaction of bodies.
- ❖ It is that which changes the state of motion of a body.
- ❖ The SI unit of force is **the newton (N)**.
- ❖ Force has both magnitude and direction and is represented by a straight line with an arrow as shown below.

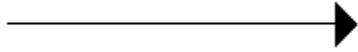

- ❖ The length of the line shows the magnitude of the force while the arrow head shows the direction of the force.

Effects of Force

- i. Force can make stationary object move.
- ii. It can increase speed of moving object.
- iii. It can stop a moving object.
- iv. It can decrease speed of moving object.
- v. It can change shape of an object (i.e. can deform an object).
- vi. It can make an object turn about a fixed point (pivot). This is called turning effect of force.
- vii. It can change the direction of a moving object.

Exercise

Which of the effects above can be caused by:

- a) A push only?
- b) A pull only?
- c) A push or a pull?

TYPES OF FORCE

1. Gravitational Force

- ❖ It refers to the force of attraction between any two bodies e.g. force of attraction between the earth and the moon.
- ❖ Gravitational force is a **non-contact force**.

Gravitational Force of the Earth

- ❖ It is the force of attraction on bodies toward the centre of the earth.

Factors affecting gravitational force

- Masses of the objects - The larger the masses the stronger the gravitational force.
- Distance of separation between the two objects. The longer the distance of separation the weaker gravitational force.

Examples

- a) **What are non-contact forces?**
 - ❖ There are forces which act even if objects are not in contact with one another.
- b) **Explain why a ball thrown upwards returns back to the ground**
 - ❖ It is due to attraction by earth's gravitational force

c) The figure below shows two objects of mass m_1 and m_2 acted upon by a force F

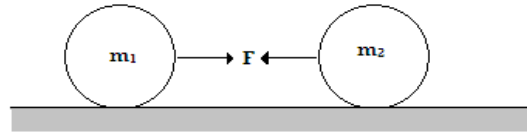

Identify force F
Gravitational force

2. Centripetal Force

- ❖ This is a force which maintains a body to move in a circular orbit or path.
- ❖ It is directed towards the centre of the circular orbit / track.

Examples of situations in which centripetal force acts include:

- Whirling a stone tied to a string.

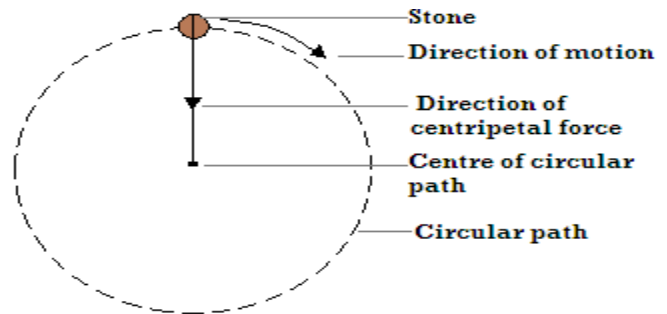

- The earth revolving around the sun along its orbit.
- Centrifuge used to separate ghee from milk.
- A car moving round a circular track or road (corner).

3. Magnetic force

- ❖ Magnetic force is the force of attraction or repulsion due to a magnet.
- ❖ It is **non-contact force**.
- ❖ Magnetic **attraction** occurs between a magnet and a magnetic material or between unlike poles of a magnet while **repulsion** occurs between like poles of magnet.

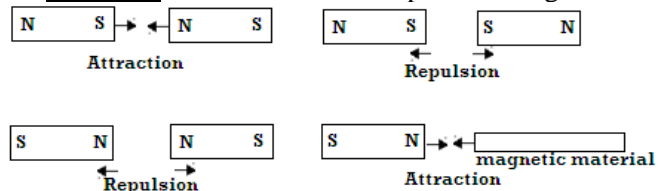

4. Upthrust force

- ❖ Upthrust is an upward force acting on objects immersed in fluids (liquids or gases).
- ❖ Upthrust can also be defined as the apparent loss in weight of a body immersed in a liquid or gas.

Upthrust on a body
 = **weight of body in air**
 – **weight of body in fluid**

❖ Upthrust is a **contact force**.

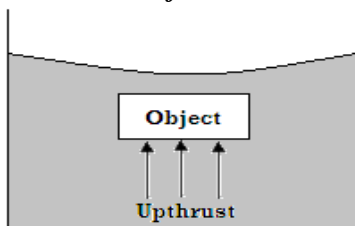

Examples of situations in which upthrust force acts include:

- Balloons to rising
- Swimmers and boats floating
- Bodies immersed in liquids weighing less than their weight in air.

Numerical Example

A body weighs 100 N in air and 80 N when submerged in water. Calculate the upthrust acting on it.

$$\begin{aligned} \text{upthrust} &= \text{apparent loss in weight} \\ &= 100\text{N} - 80\text{N} = 20\text{N} \end{aligned}$$

5. Frictional Force

- ❖ This is a force that opposes motion between two surfaces that are in contact.
- ❖ Frictional force in fluids (liquid and gases) is called **viscous drag (viscosity)**.
- ❖ Frictional force is a **contact force** and it **acts** in the **direction opposite** to that of motion of the body.



Advantages of Frictional Force

Frictional force helps in:

- a) Writing.
- b) Braking.
- c) Walking.
- d) Erasing.
- e) Lighting a match stick etc

Disadvantages of Frictional Force

- a) Causes wear and tear.
- b) Hinders motion.
- c) Produces unwanted heat.
- d) Produces unwanted sound.

Methods of Reducing Frictional Force

- i) Oiling and greasing.
- j) Using rollers.
- k) Streamlining bodies.

- f) Smoothing surfaces.
- g) Using ball bearings.
- h) Air cushioning

6. Electrostatic Force

- ❖ Electrostatic force is the force of attraction or repulsion between electrically charged bodies.
- ❖ It is non-contact force. There are **two types** of **electrical charges (positive and negative)**.
- ❖ Attraction occurs between unlike charges i.e. positive and negative while repulsion occurs between like charges.

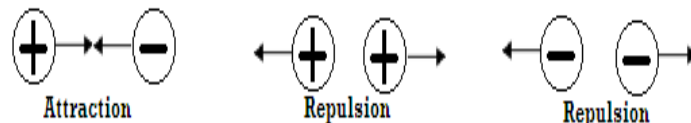

Examples of situations in which electrostatic force acts include:

- a) A plastic ruler or pen rubbed with piece of dry cloth or hair attracts pieces of paper.
- b) A wiped glass window rapidly attracts dust due to charges left on them during wiping.
- c) Polished shoes rapidly attract dust due to charges left on them during brushing.
- d) A nylon cloth produces crackling sound and sticks on the body when being removed etc.

7. Action and Reaction Forces

- ❖ Action and reaction are two equal forces acting in opposite directions.
- ❖ They are **contact forces**.
- ❖ When a block of wood is placed on a table, its weight (action) acts on the table. The reaction of the table (opposite force) acts on the block.

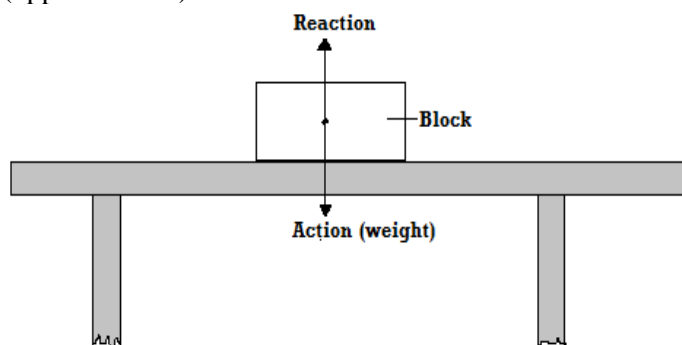

8. Nuclear Force

- ❖ This is a force that binds protons and neutrons in atomic nuclei.
- ❖ Nuclear force is a **contact force**.

9. **Tension Force**

- ❖ It is a force which acts on stretched bodies.
- ❖ Tension is as a result of two opposing forces applied one at each end of a body.
- ❖ It is a **contact force**.

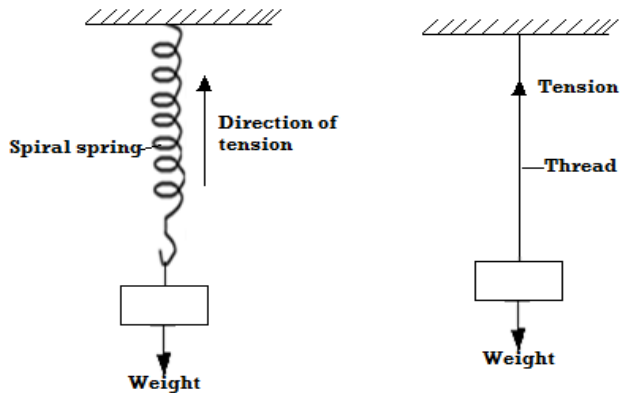

10. **Surface Tension**

- ❖ Surface tension is defined as the force per unit length in the plane of a liquid surface acting at right angles on either side of an imaginary line drawn in that surface.

Molecular Explanation of Surface Tension

- ❖ A molecule deep in the liquid is surrounded by liquid on all sides so that the net force on it is zero. A molecule on the surface has fewer molecules on the vapour side and therefore will experience a resultant inward force, causing the surface of the liquid to be in tension.

Examples of situations in which surface tension force acts include:

- i) A steel razor blade or needle floats when carefully placed on water although steel is denser than water.



- ii) A glass of water can be filled with water above the brim without water pouring out. This is due to surface tension on the surface of water.

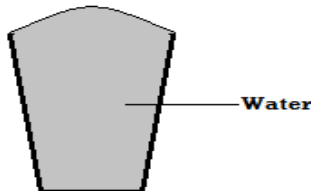

- iii) Bristles of a brush spread in water but cling together when the brush is retrieved out of water. The clinging together of bristles is due to surface tension of water on the surface of bristles.

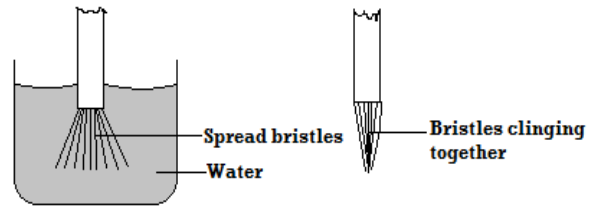

- iv) A drop of water from a burette or water tap grows and stretches out before it falls off due to surface tension on the surface of the drop.

Note: Surface tension acts along the surface of a liquid so as to reduce surface area. This can be illustrated by the following observations:

- i) When bubble of soap is blown to the wide end of the funnel and the left with the upper end, the bubble recedes slowly until it flattens to a film. It therefore makes its surface as small as possible.

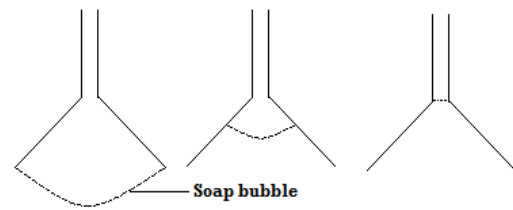

- ii) When a film of a soap contained in a wire loop is punctured or pierced at point X as shown below, the remaining part of the film acquires a minimum area. The thread is therefore pulled from one side making a perfect curve. This is because of forces of surface tension from one side only.

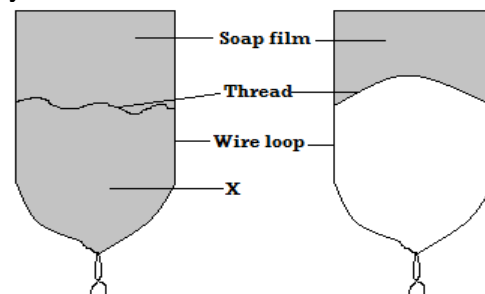

Factors Affecting Surface Tension

i) Impurities

- ❖ Impurities reduce surface tension of a liquid. Soap (detergent) weakens the cohesive forces between surface liquid molecules and therefore reducing surface tension.

ii) Temperature

- ❖ Temperature reduces surface tension of the liquid because it weakens cohesive force of attraction between liquid molecules.

- ❖ The level of mercury in capillary tubes is lower than that

EXERCISE

Explain the following observations:

- a) A steel needle placed carefully on the surface of water does not sink.
- b) When a small drop of detergents is placed on water, the floating needle moves rapidly away from it and sinks when more detergent is added
- c) A match stick wrapped at one end with soap starts moving immediately in one direction when placed on the surface of water.

11. Adhesion (adhesive force)

❖ Adhesion refers to the force of attraction between molecules of different kind e.g. force of attraction between water and glass molecules.

Examples of situations in which adhesive force acts include:

- 1) Liquid wetting glass.
- 2) Paint sticking on wall.
- 3) Ink sticking on paper.
- 4) Chalk mark sticking on the board.

12. Cohesion (Cohesive Force)

❖ Cohesion refers to the force of attraction between molecules of same kind e.g. force of attraction between water molecules.

Some Effects of Adhesive and Cohesive Forces

a) Capillary Tubes Dipped in Water

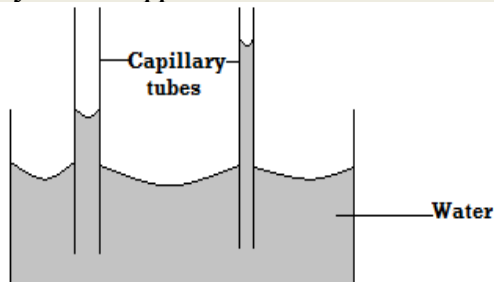

- ❖ In both capillary tubes water curves upwards at the edge (wets glass). The rise of water up the tube is due to adhesive forces between glass and water molecules being stronger than cohesive force of attraction between water molecules.
- ❖ The upward curve is called **concave meniscus**.

b) Capillary Tubes Dipped in Mercury

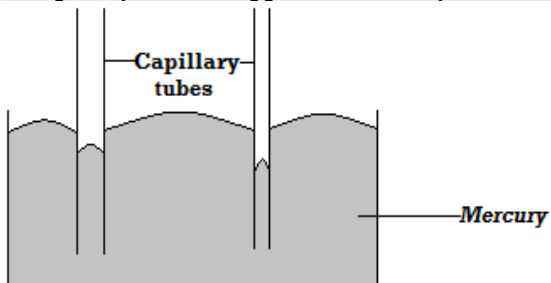

- of mercury in the basin. Being lowest in the narrow tube.
- ❖ In both capillary tubes mercury curves downwards at the edge (does not wet glass). This is due to stronger cohesive force between mercury molecules than adhesive forces between mercury and glass molecules.
- ❖ The downward curve is called **convex meniscus**

Water on Clean and Waxed glass surfaces

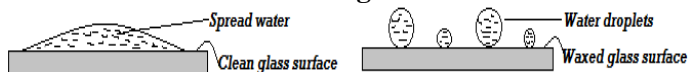

- ❖ When water is dropped on a clean piece of glass, it spreads because adhesive forces between glass and water molecules are stronger than cohesive forces between water molecules.
- ❖ When water is dropped on waxed glass surface, it rolls into small droplets. This is because waxing reduces adhesive force between water and glass molecules. Cohesive force becomes greater than adhesive force.

Mass and Weight

- ❖ **Mass** is defined as the quantity of matter in a body.
- ❖ **Weight** is the gravitational pull on a body. It is a force and therefore its SI unit is **Newton (N)**.
- ❖ The **direction of action of weight** on earth is towards the centre of the earth

Relationship between Mass and Weight

❖ Mass and weight are related as follows:

$$\begin{aligned} \text{weight} \\ = \text{mass} \times \text{acceleration due to gravity} \\ \text{(Gravitational field strength)} \\ W = Mg \end{aligned}$$

Definition of acceleration due to gravity (g)

- ❖ It is defined as the gravitational force acting on a unit mass at a place.
- ❖ The **SI unit of g** (gravitational field strength) is **the newton per kilogram (N/kg)**
- ❖ **Note:** A graph of weight versus mass is a straight line through the origin and the slope of the graph gives acceleration due to gravity, g i.e.

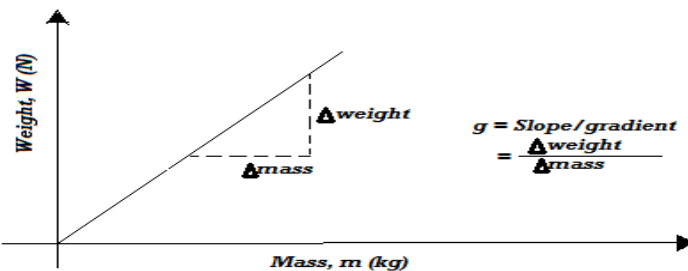

Differences between Mass and Weight

Mass	weight
The quantity of matter in an object body	Gravitational pull on an object
The SI unit kg (kilogram)	SI unit is the newton
Constant everywhere	Varies from place to place
A scalar quantity	A vector quantity
Measured using a beam balance	Measured using a spring balance

Examples

1. State a reason as to why weight of a body varies from place to place on the earth's surface.

Gravitational field strength varies from one place to another on the earth's surface being strong at the poles and weak at the equator.

2. An object weighs 1000N on earth's surface ($g = 10N/kg$)

a) Calculate its mass.

$$w = mg$$

$$1000 N = m \times 10 \frac{N}{kg}$$

$$m = \frac{1000 N}{10 N/kg} = 100 kg$$

b) If the same object weighs 160N on the moon surface, find the gravitational field strength of the moon.

$$W = mg$$

$$160 = 100 \times g$$

$$g = \frac{160}{100} = 1.60 N/kg$$

3. A mass of 7.5kg has a weight of 30N on a certain planet. Calculate the acceleration due to gravity on this planet.

$$W = mg$$

$$30 = 7.5 \times g$$

$$g = \frac{30}{7.5} = 4N/kg$$

4. A man has a mass of 70kg. calculate :

a) His weight on earth where the gravitational field strength is 10N/kg.

$$W = mg$$

$$70 \times 10 = 700 N$$

b) His weight on moon where the gravitational field strength is 1.7N/kg.

$$W = mg$$

$$70 \times 1.7 = 119 N$$

Scalar and Vector Quantities

1) **Scalar Quantity**

❖ A scalar quantity is one with *magnitude only* but no direction e.g.

- a) Time
- b) Temperature
- c) Energy
- d) Speed
- e) Area
- f) Volume
- g) Length
- h) Mass

i) Distance.

1)

2) **Vector Quantity**

A vector quantity is one with *both magnitude and direction* e.g.

i) Weight

ii) Force

iii) Velocity

iv) Momentum

v) Acceleration

vi) Displacement

❖ If the weight of a car is 8000 N, 8000 gives magnitude of the weight, N is the SI unit and direction is towards the centre of the earth.

Resultant vector

❖ This is the sum of two or more vectors taking into account the direction of the vectors.

Example

Find the resultant force of the forces acting on a point object shown below.

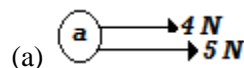

Solution

$$(+4 N) + (+5 N) = +9 N$$

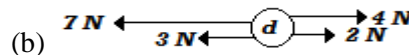
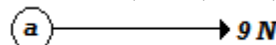

Solution

$$(-7 N) + (-3 N) + (+2 N) + (+4 N) = -4 N$$

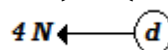

Examples

1) The figure below shows two glass tubes of different diameter dipped in water.

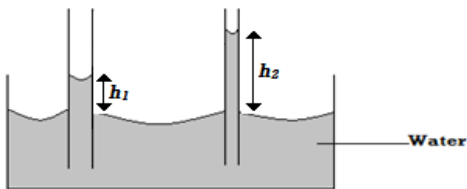

Explain why h_2 is greater than h_1

- i) Adhesive force in narrow tube is greater than adhesive force in wider tube.
 - ii) Volume of water in both tubes is the same hence the column of water in narrow tube h_2 is greater.
- 2) Name two forces that determine the shape of liquid drop on the solid surface
Cohesive and adhesive forces
- 3) Give a reason why weight of the body varies from place to place.
The gravitational field strength varies from place to place.
- 4) A metal bin was observed to float on the surface of pure water. However the pin sank when a few drops of soap solution were added to the water. Explain this observation.
Soap solution is an impurity. When added to water, it lowers the surface tension (by dissolving) of water making the needle to sink.

Revision Exercise

- 1) By considering action-reaction forces, identify why water rises up a thin capillary tube.
- 2) Give two examples of contact force and non-contact force.
- 3) Sketch how a vector quantity is represented on a diagram.
- 4) Define force and give SI unit.
- 5) Name all the forces acting on the following bodies:
 - (a) A box placed on a table
 - (b) A mass suspended from a spring balance.
 - (c) A moving car negotiating a bend.
- 6) Define cohesive force and adhesive force.
- 7) Explain why a man using a parachute falls through air slowly while a stone fall through air very fast.
- 8) A spring stretches by 6cm when supporting a load of 15N.
 - (b) By how much would it stretch when supporting a load of 5kg?
 - (c) What load would make the spring extend by 25mm?
- 9) Explain each of the following, using the behaviour of molecules where possible:
 - (a) A steel needle placed carefully on the surface of water does not sink.
 - (b) When a small drop of detergent is placed on water, the needle moves rapidly away from it and sinks when more detergent is added. (assume that detergent does not affect the density of water)
 - (c) A match –stick rubbed at one end with soap starts moving immediately in one direction when placed on the surface of water.
- 10) Define surface tension.
 - a) How does temperature rise and impurities affect the surface tension of water?
 - b) How would the surface tension of water be increased?

- 11) Define the terms.
 - a) Mass
 - b) Weight.
- 12) The mass of a lump of gold is constant everywhere, but its weight is not. Explain this.
- 13) A man has a mass of 70kg. Calculate:
 - a) His weight on earth, where the gravitational field strength is 10N/kg.
 - b) His weight on the moon, where the gravitational field strength is 1.7N/kg.
- 14) A mass of 7.5kg has weight of 30N on a certain planet. Calculate the acceleration due to gravity on this planet.
- 15) Define the following terms, giving examples.
 - a) Vector quantity
 - b) Scalar quantity
- 16) (a) Define a resultant vector.
 - (a) Find the resultant of a force of 4N and a force of 8N acting at the same point on an object if:
 - i) The force act in the same direction in the same straight line.
 - ii) The force act in the opposite directions but in the same straight line.
- 17) Show diagrammatically how forces of 7N and 9N can be combined to give a resultant to give a resultant force of:
 - (a) 16N (b) 2N

Chapter Four

PRESSURE

Definition of Pressure

- ❖ Pressure refers to force acting perpendicularly per unit area.
- ❖ Since force is measured in newtons and area in square meter, then the SI unit of pressure is *the newton per square meter (N/m²) or the pascal (Pa)*. *1 newton per square meter (N/m²) = 1 pascal (Pa)*

$\text{Pressure} = \frac{\text{Force}}{\text{Area}}$	$F = P \times A$
$P = \frac{F}{A}$	$A = \frac{F}{P}$

Pressure in Solids

Force exerted by a solid resting on a surface is equal to the weight the object.

$$\text{Pressure} = \frac{\text{Force (weight of solid)}}{\text{Area of contact}}$$

$$\text{Maximum Pressure} = \frac{\text{weight of solid}}{\text{Minimum Area}}$$

$$\text{Minimum Pressure} = \frac{\text{weight of solid}}{\text{Maximum Area}}$$

Factors Affecting Pressure in Solids

1. Weight of the solid (force)

- ❖ If the area of contact between solid and surface is constant, pressure increases with weight.

2. Area of contact of the solid with surface.

- ❖ The smaller the area, the higher the pressure if same force is applied. Therefore pressure can be reduced by increasing the area of contact.

Examples

1. A block of a soap stone of dimension 4m by 2m by 3m is 48kg and is made to rest on a smooth horizontal surface
2. Calculate the minimum pressure it exerts on the surface.
3. Calculate the maximum pressure it will exert on the surface

$$\begin{aligned} \text{a) Minimum Pressure} &= \frac{\text{Weight}}{\text{Maximum Area}} \\ &= \frac{48 \times 10}{4 \times 3} \\ &= \frac{480}{12} = 40 \text{ N/m}^2 \end{aligned}$$

$$\text{b) Maximum Pressure} = \frac{\text{Weight}}{\text{Minimum area}} = \frac{480}{2 \times 3} = 80 \text{ N/m}^2$$

5. An object whose area of contact with the floor is 5m² exerts a pressure of 900 pascal. Calculate its mass

$$\begin{aligned} F(\text{Weight}) &= P \times A \\ \text{Weight} &= 900 \text{ N/m}^2 \times 5 \text{ m}^2 \\ m &= \frac{W}{g} \end{aligned}$$

$$= \frac{4500 \text{ N}}{10 \text{ N/kg}} = 450 \text{ kg.}$$

6. Tracks which carry heavy loads have many wheels. Explain.

Many wheels increase the area of contact with the ground thereby reducing pressure exerted on the road. This prevents damage of the roads by tracks.

7. A block of copper of density 9g/cm³ measures 5cm by 3cm by 2cm. Given that g is 10N/kg, determine:

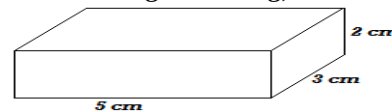

a) The maximum pressure

$$\begin{aligned} \text{Maximum pressure} &= \frac{\text{Weight}}{\text{Minimum area}} \\ \text{Maximum pressure} &= \frac{\rho V g}{\text{Minimum area}} \\ &= \frac{9000 \frac{\text{kg}}{\text{m}^3} \times (30 \times 10^{-6} \text{ m}^3) \times 10 \text{ N/kg}}{6 \times 10^{-4} \text{ m}^2} \\ &= 4500 \text{ N/m}^2 \end{aligned}$$

b) The minimum pressure that it can exert on a horizontal surface.

$$\begin{aligned} \text{Minimum pressure} &= \frac{\text{Weight, } W}{\text{Maximum area}} \\ &= \frac{2.7 \text{ N}}{15 \times 10^{-4} \text{ m}^2} \\ &= \frac{2.7 \text{ N}}{0.0015 \text{ m}^2} = 1800 \text{ N/m}^2 \end{aligned}$$

8. It is painful if one tries to lift a heavy load by a thin string.

There is a small area of contact with the fingers when a thin string is used. As a result, more pressure is generated and this is painful.

Exercise

1. A pick up carrying stones weighs 40,000N. The weight is evenly spread across the 4 tyres. The area of contact of each tyre with the ground is 0.05m². Calculate the pressure exerted by each tyre on the ground.
2. A thumb is used to push a thumb pin into a piece of wood. Explain in terms of pressure why the pressure on wood is greater than the pressure on the thumb.
3. An elephant of mass 2800kg has feet of average area of 200 cm². A vulture of mass 12 kg walks beside the elephant on a muddy area, the average area of the feet of the vulture is 2.0 cm². Which one is likely to sink? Explain your answer showing any necessary calculations.
4. A girl standing upright exerts a pressure of 15000 N/m² on the floor. Given that the total area of contact of shoes and the floor is 0.02m².
 - a) Determine the mass of the girl.
 - b) Determine the pressure she would exert on the floor if she stood on one foot.
5. A block of copper of density 8.9 g/cm³ measures 10 cm × 6 cm × 4 cm. Given that the force of gravity is 10Nkg⁻¹, determine:
 - a) The maximum pressure.
 - b) The minimum pressure that it can exert on a horizontal surface.

Pressure in Liquids

Factors Affecting Pressure in Liquids

1. Depth of the Liquid

- ❖ Pressure in liquids increases with depth.
- ❖ This is the reason as to why walls of a dam are thicker at the bottom than at the top as shown below. Thick walls at the bottom of the dam withstand high pressure due to water at the bottom.
- ❖ Pressure increasing with depth of liquid explains why a diver at the bottom of the sea experiences more pressure due to more weight of water above him than a diver near the top/ surface of the sea.

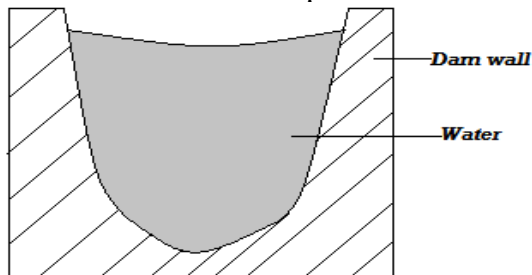

2. Density of the Liquid

- ❖ Pressure in liquids increases with density of the liquid.
- ❖ Consider two identical cylinders filled with water (of density 1000kg/m³) and glycerine (of density 1260kg/m³) respectively.
- ❖ Pressure at point B is greater than pressure at point A because glycerine is denser than water and therefore exerts more pressure than water.

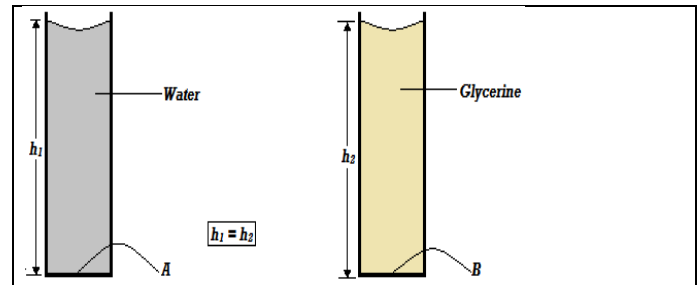

To Demonstrate Variation of Pressure with Depth of Liquids

- ❖ Consider a tall tin with holes A, B and C equally spaced on one side along a vertical line as shown below.
- ❖ When the tin is filled with water, the water jets out of the holes with that from hole A thrown farthest followed by that from hole B and lastly from hole C.
- ❖ This means that pressure of water at A is greater than pressure at B and pressure at B is greater than pressure at C. Hence, Pressure in liquids increases with depth.

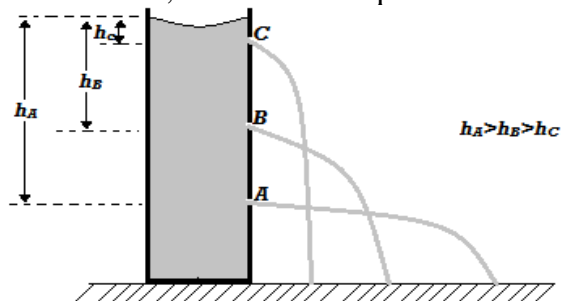

To Demonstrate Variation of Pressure with Depth and Density of Liquids

- ❖ Consider a transparent glass vessel filled with water and a thistle funnel connected to a u-tube filled with colored water to some level dipped into it.
- ❖ It is observed that the deeper the funnel goes below the surface of water, the greater the difference in levels of water in the two limbs of the u-tube, h. This is due to increase in pressure with depth.

❖ When glycerine is used in place of water it is observed that at the same depth the difference in levels, h is greater than when water is used. This is because glycerin is denser than water and therefore it is pressure at same depth is higher than that of water.

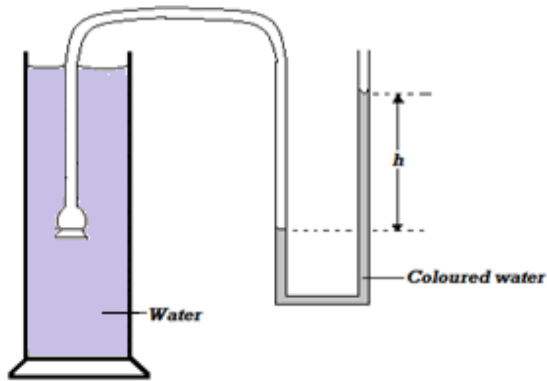

To Demonstrate that Pressure at Equal Depth, Acts Equally in All Directions

❖ Consider a tin with two similar holes on its side at same height as shown alongside.
 ❖ When the tin is filled with water, it is **observed** that water travels out of the holes equal horizontal distances from the can. Therefore pressure exerted at equal depth is same in all directions.

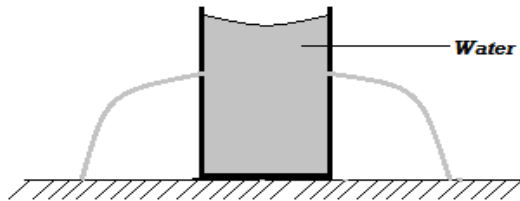

Fluid Pressure Formula

❖ Consider a container with cross- section area, A , filled with a liquid of density, ρ , to the height, h , as shown alongside.

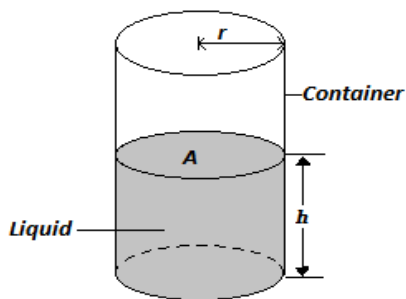

❖ The pressure p , exerted at the bottom (base) of the container by the weight of the liquid above it is given by:

$$P = \frac{F}{A}$$

$$= \frac{w(\text{weight of liquid})}{A(\text{cross - section area of the container})}$$

But $w = \rho Ahg$

Where $Ah = \text{volume of the liquid}$

$$\therefore P = \frac{Ah\rho g}{A}$$

$P = h\rho g$. This is the **fluid pressure formula**.

❖ From the formula it is clear that *pressure in fluids does not depend on cross- section area of the container holding the liquid.*

Examples

1.) A diver working under water is 15 m below the surface of the sea. Calculate the pressure due to water experienced by the diver (take $g=10N/kg$) and density of sea water to be equal to $1.03g/cm^3$.

$$P = h\rho g$$

$$= 15 \text{ m} \times 1030 \text{ kg/m}^3 \times 10 \text{ N/kg}$$

$$= 154500 \text{ N/m}^2$$

2.) The figure below shows a liquid in a pail.

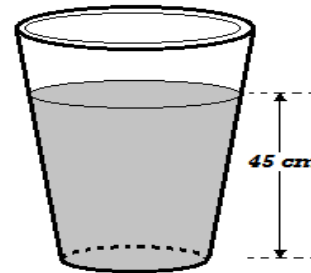

If the liquid has a density of 0.79 g/cm^3 , determine the pressure exerted at the bottom of the pail by the liquid.

$$P = h\rho g$$

$$= 0.45 \text{ m} \times 790 \text{ kg/m}^3 \times 10 \text{ N/kg}$$

$$= 3555 \text{ N/m}^2$$

b) Suggest a reason why pail manufactures prefer the shape shown to other shapes

To reduce the height of the pail but maintain the capacity. This reduces the pressure exerted by the liquid at the bottom of the pail.

3.) Calculate the pressure exerted by 76 mm column of mercury given that its density is $13.6g/cm^3$

$$p = h\rho g$$

$$= 0.76 \text{ m} \times 13600 \frac{\text{kg}}{\text{m}^3} \times 10 \text{ N/kg}$$

$$= 103360 \text{ N/m}^2$$

4.) A column of glycerin 8.20m high, a column of sea water 10.08m high, a column of mercury 0.76m high and column of fresh water 10.34 m high exert the same pressure at the bottom of a container. Arrange these substances in decreasing order of their densities.

Mercury, glycerine, sea water, fresh water

Pascal's Principle (The Principle of Transmission of Pressure in Liquids)

❖ Pascal's principle states that pressure applied at one part in a liquid is transmitted equally to all other parts of the enlarged liquid.

Demonstrating Pascal's Principle

❖ Consider a liquid under pressure due to force, F, acting on the plunger as shown below.

❖ Note: The holes are of equal diameter.

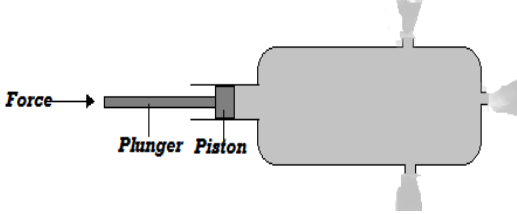

❖ When the plunger is pushed in, water squirts out of the holes with equal force. This shows that pressure generated by the piston on the water is transmitted equally to all other parts of the liquid.

Applications of Pascal's Principle

❖ Pascal's Principle is applied in the working of the hydraulic machines. These machines include:

- a) **Hydraulic press** used to compress textile products like blankets for packing.
- b) **Hydraulic lift** used to hoist cars in garages.
- c) **Hydraulic brake system** used for braking in cars.

Pressure Transmission in Hydraulic Machines

❖ Note that pressure at same level in the liquid is the same as seen earlier.

❖ Consider the hydraulic machine below consisting of a small piston, S, and a large piston, L, of cross-section as shown alongside.

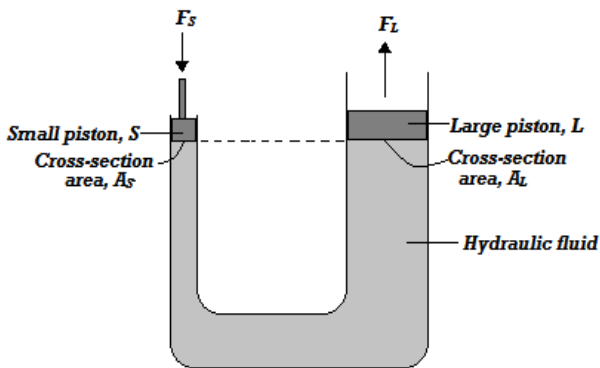

❖ Pressure exerted on the liquid by piston, S due to force, F_S is P_S.

$$P_S = \frac{F_S}{A_S}$$

❖ By Pascal's principle this pressure P_S is equal to pressure P_L exerted by liquid on piston, L.

$$P_S = P_L$$

$$\frac{F_S}{A_S} = \frac{F_L}{A_L}$$

Examples

1. The figure below shows two masses placed on light pistons. The pistons are held stationary by the liquid whose density 0.8g/cm³. Determine the force F.

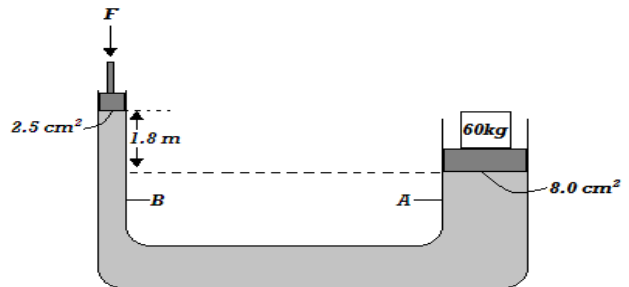

$$\begin{aligned} \circ \quad h\rho g + \frac{F_B}{A_B} &= \frac{F_A(\text{i.e. } w=mg)}{A_A} \\ \circ \quad \frac{60 \times 10 \text{ N}}{0.0008 \text{ m}^2} &= 1.8 \text{ m} \times 800 \frac{\text{kg}}{\text{m}^3} \times 10 \text{ N/Kg} + \frac{F_B}{0.00025 \text{ m}^2} \\ \circ \quad 750000 \frac{\text{N}}{\text{m}^2} &= 1440 \text{ N/m}^2 + \frac{F_B}{0.00025} \\ \circ \quad F_B &= \left(750000 \frac{\text{N}}{\text{m}^2} - 1440 \frac{\text{N}}{\text{m}^2} \right) 0.00025 \text{ m}^2 \\ &= 187.14 \text{ N} \end{aligned}$$

2. The area of the large syringe in an experiment is 18cm² and that of the smaller one is 3.0cm². A force of 2N is applied on the smaller piston. Find the force produced on the larger piston.

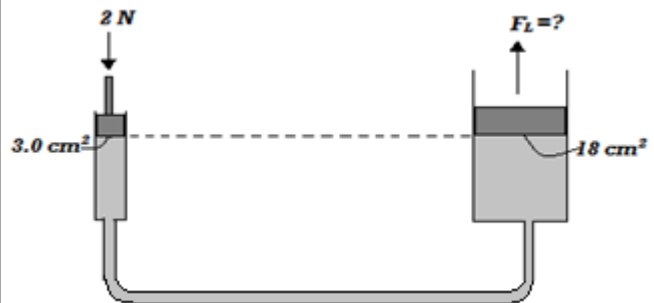

$$\frac{F_s}{A_s} = \frac{F_L}{A_L}$$

$$\frac{2 \text{ N}}{0.0003 \text{ m}^2} = \frac{F_L}{0.0018 \text{ m}^2}$$

$$F_L = \frac{2 \text{ N} \times 0.0018 \text{ m}^2}{0.0003 \text{ m}^2} = 12 \text{ N}$$

4. The diagram below shows a u-tube filled two liquids, x and y. If the density of liquid y is 1.00 g/cm³, determine the density of liquid x.

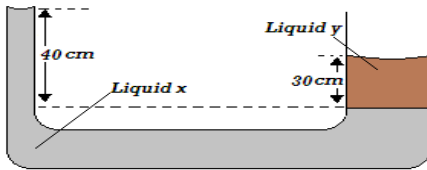

$$h_x \rho_x g = h_y \rho_y g$$

$$0.40 \text{ m} \times \rho_x \times 10 \frac{\text{N}}{\text{kg}} = 0.30 \text{ m} \times 1000 \frac{\text{kg}}{\text{m}^3} \times 10 \text{ N/kg}$$

$$\frac{4.0 \text{ Nm}}{\text{kg}} \times \rho_x = 3000 \frac{\text{N}}{\text{m}^2}$$

$$\rho_x = 750 \frac{\text{kg}}{\text{m}^3}$$

Hydraulic Brake System

❖ The hydraulic brake system uses the principle of transmission of pressure in liquids (Pascal's principle) in its operation.

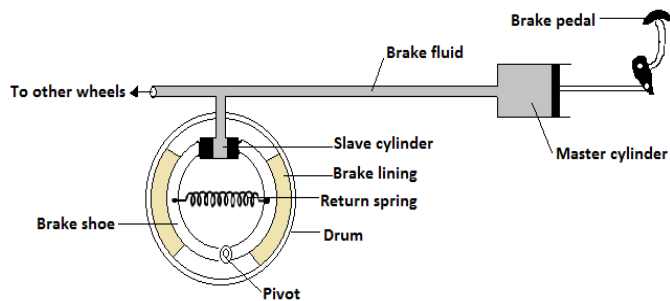

Mode of Operation of Hydraulic Brake System

- ❖ When a small force is applied on the **brake pedal**, it pushes the piston of the **master cylinder** inwards. This produces a pressure that is equally transmitted to the pistons in the **slave cylinders**. The pressure generates a force which pushes the pistons of the slave cylinder outwards. The pistons then push the **brake shoes** and therefore the **brake lining** outwards. The brake lining touches and stops rotating wheel drum.
- ❖ The **return spring** returns the brake shoes into their original position after force on brake pedal has been removed.

Properties of the Hydraulic Brake Fluid

- (a) It should not corrode parts of the system
- (b) It should be highly incompressible
- (c) It should have a low freezing point and high boiling point.

Atmospheric Pressure

❖ This is the pressure exerted on the earth's surface by the column of air around it.

To Demonstrate Existence of Atmospheric Pressure (Crushing Can Experiment)

❖ Consider a tin container with some water in it. The container is heated for some time while open and closed after withdrawing heating. Cold water is then poured on it immediately.

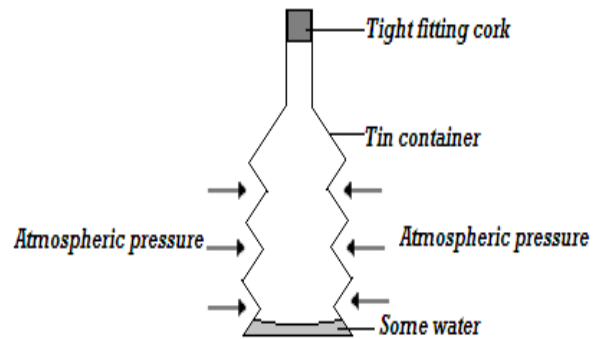

❖ It is **observed** that the **container crushes inwards** when cold water is poured on it. This is because steam from boiling water drives out the air inside the container and a partial vacuum is created when the container is cooled. The higher atmospheric pressure from the outside **crushes** the container **inwards**.

Example

A sea diver is 18 m below the surface of sea water. If the density of sea water is 1.03g/cm³ and g is 10N/kg, determine the total pressure on him. (Take atmospheric pressure $p_a = 103\,000 \text{ N/m}^2$).

$$\begin{aligned} \text{Total pressure} &= h\rho g + P_a \\ &= 18 \text{ m} \times 1030 \frac{\text{kg}}{\text{m}^3} \times 10 \frac{\text{N}}{\text{kg}} + 103\,000 \text{ N/m}^2 \\ &= 288\,400 \text{ N/m}^2 \end{aligned}$$

Measurement of Pressure

1) U- Tube Monometer

- ❖ It is used to measure gas pressure.
- ❖ It consists of u- tube filled with suitable liquid to some level.
- ❖ Consider u-tube manometer below in which one limb is connected to gas supply.

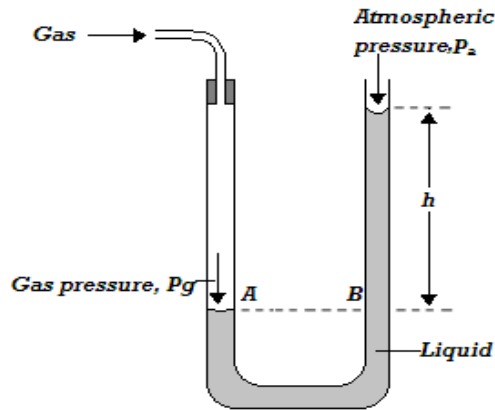

- ❖ A and B are at the same horizontal level and therefore pressure at A is equal to pressure at B.
- ❖ Pressure at A is due to the gas, p_g while pressure at B is due to the column of liquid and atmospheric pressure.

Pressure at A, $P_A =$ Pressure at B, P_B

$$P_g = h\rho g + P_a$$

- ❖ Where ρ is the density of liquid in the u- tube.

Examples

1) The height, h of a water manometer is 20 cm when used to measure pressure of a gas.

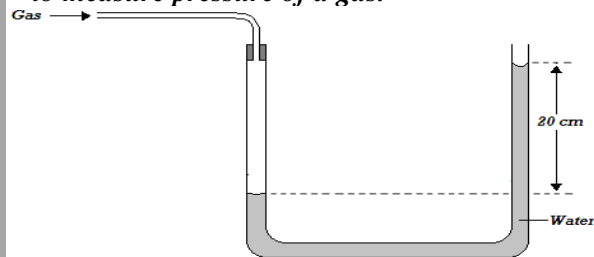

a) Determine the pressure due to gas, If atmospheric pressure is 103000N/m^2 .

$$\begin{aligned} \circ P_g &= h\rho g + P_a \\ \circ &= 0.20\text{ m} \times 1000\text{ kg/m}^3 \times 10\text{N/kg} + 103000\text{N/m}^2 \\ \circ &= 105000\text{N/m}^2 \end{aligned}$$

b) What would be the height if the liquid used is glycerin of density 1.26g/cm^3

$$\begin{aligned} \circ P_g &= h\rho g + P_a \\ \circ 105000\frac{\text{N}}{\text{m}^2} &= h \times 1260\text{kg/m}^3 \times 10\text{N/kg} + 103000\text{N/m}^2 \\ \circ 105000\text{N/m}^2 &= 12600\text{N/m}^3 \times h + 103000\text{N/m}^2 \\ \circ 2000\text{N/m}^2 &= 12600\text{N/m}^3 \times h \\ h &= \frac{2000\text{N/m}^2}{12600\text{N/m}^3} = 0.16\text{ m} \end{aligned}$$

2) The diagram below show a mercury manometer. Some dry gas is present in the closed space. If the atmospheric pressure is 105000N/m^2 and density of mercury 13600kg/m^3 , determine pressure of the gas (take $g=10\text{N/kg}$).

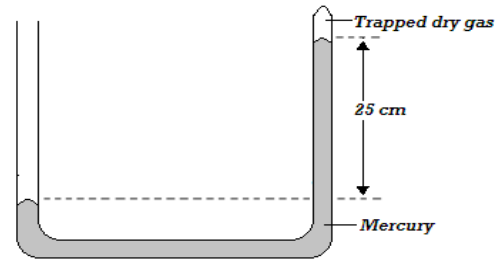

$$\begin{aligned} \circ h\rho g + P_g &= P_a \\ \circ 0.25\text{ m} \times 13600\frac{\text{kg}}{\text{m}^3} \times 10\frac{\text{N}}{\text{kg}} + P_g &= 105000\text{N/m}^2 \\ \circ 34000\text{N/m}^2 + P_g &= 105000\text{N/m}^2 \\ \circ P_g &= 105000\frac{\text{N}}{\text{m}^2} - 34000\frac{\text{N}}{\text{m}^2} \\ \circ &= 71000\text{N/m}^2 \end{aligned}$$

2) Mercury Barometer

- ❖ It is used to measure atmospheric pressure.
- ❖ It employs the fact that atmospheric pressure supports a column of liquid in a tube.

Construction of Mercury Barometer

- ❖ It is made of a thick- walled glass tube of about 1m long sealed at one end.
- ❖ The tube is then filled carefully with mercury to the top.
- ❖ Any bubbles of air in the tube are removed by closing the open end and inverting the tube severally.
- ❖ The tube is then inverted into a dish filled with mercury.
- ❖ Mercury is preferred in the construction of barometer to other liquids because its **very high density**.

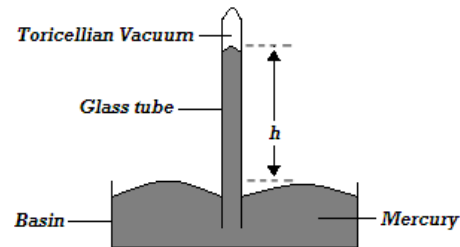

Using Mercury Barometer

- ❖ The height h , of the mercury column is the measure of atmospheric pressure.
- ❖ The column of mercury h , at sea level is 76cmHg. In SI unit it is:

$$P_a = h\rho g$$

$$0.76 \text{ m} \times 13600 \text{ kg/m}^3 \times 10 \text{ N/kg} = 103360 \text{ N/m}^2$$

- ❖ The atmospheric pressure at sea level is called one atmosphere or standard atmospheric pressure (76cmHg or 103360N/m²)

Examples

- 1) A student in a place where the mercury barometer reads 75cm wanted to make an alcohol barometer. If alcohol has a density of 800 kg/m³, what is the minimum length of the tube that could be used?

$$P_a = h_{Hg} \rho_{Hg} g = h_{al} \rho_{al} g$$

$$0.75 \text{ m} \times 13600 \text{ kg/m}^3 \times 10 \text{ N/kg}$$

$$= h_{al} \times 800 \text{ kg/m}^3 \times 10 \text{ N/kg}$$

$$h_{al} = \frac{10200}{8000} = 12.75 \text{ m}$$

- 2) The barometric height in a town is 70cm mercury. Given that the standard atmospheric pressure is 76cm mercury and the density of mercury is 13600kg/m³, determine the altitude of the town. (Density of air is 1.25kg/m³).

(Note: Standard pressure refers to the atmospheric pressure at sea level).

$$P \text{ difference} = P \text{ at sea level} - P \text{ at town}$$

$$(h_{Hg \text{ sl}} - h_{Hg \text{ tn}}) \times \rho_{Hg} \times g = h_{air} \times \rho_{air} \times g$$

$$(0.76 - 0.70) \text{ m} \times 13600 \text{ kg/m}^3 \times 10 \text{ N/kg}$$

$$= h_{air} \times 1.25 \text{ kg/m}^3 \times 10 \text{ N/kg}$$

$$h_{air} = \frac{8160}{12.50}$$

$$= 652.8 \text{ m (This is the altitude of the town)}$$

- 3) The figure below shows a person sucking water using a straw. Explain how sucking is made possible.

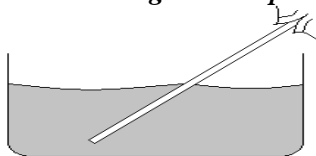

When one sucks pressure inside the straw reduces below the atmospheric pressure. The pressure difference causes water to go into the straw and rise up to the mouth.

Testing the Vacuum in the Barometer

- ❖ The vacuum is tested by tilting the tube. If the tube is fully filled then the space is a vacuum but if the tube is not fully filled then the space is not a vacuum; it has some air occupying it and therefore, the barometer is faulty.

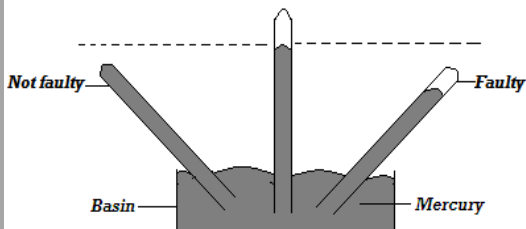

Siphon

- ❖ Siphon is used to transfer liquid from one container to another.

- ❖ The use of siphon to transfer liquid due to pressure difference is called **siphoning**. Consider the siphoning arrangement shown below.

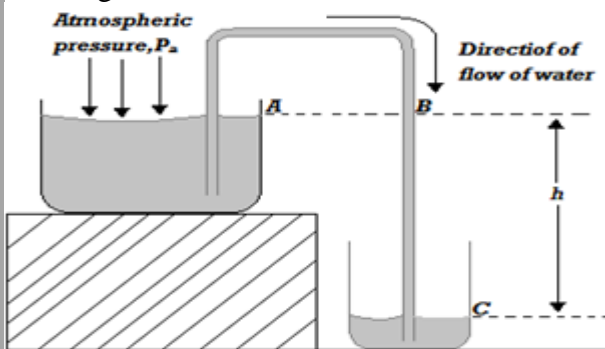

- ❖ Pressure at A is equal to pressure at B and it is the atmospheric pressure, P_a

- ❖ Pressure at c is equal to pressure at B plus pressure due to water column, h , i.e. $P_C = P_B + h\rho g$

- ❖ Pressure difference between B and C (i.e. $P_C - P_B = h\rho g$) is what makes the liquid to flow from the upper container to the lower one.

Conditions under which Siphon Works

- a) The tube must be filled with the liquid first. This creates a pressure difference.
- b) There must be a difference in levels of liquid in the two containers.
- c) The end of the tube must remain below the liquid surface of the upper container.

Example

The figure below shows how to empty water from a large tank into a low lying tank using rubber tubing.

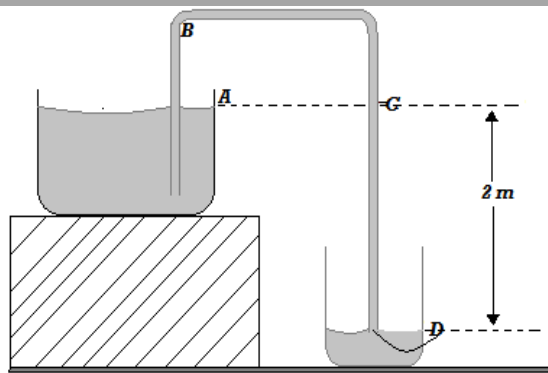

a) Explain why the tube must be filled with water before the emptying process starts.

To create pressure difference between C and D this will lead to continuous flow of water from the upper tank to the lower tank.

b) Soon after the tank begins to empty the lower end is momentarily blocked by placing a finger at end D.

I. Determine pressure difference between point A and D.

- $P_{AD} = h\rho g$
- $P_{AD} = 2m \times 1000 \frac{kg}{m^3} \times 10 \frac{N}{kg}$
- $P_{AD} = 20\,000 \text{ N/m}^2$

II. what will be the pressure experienced by the finger at point D. (take density of water = 1000 kg/m^3 and $p_a = 100,000 \text{ N/m}^2$)

- $P_D = P_{atm} + h\rho g$
- $P_D = 100000 \frac{N}{m^2} + 20\,000 \frac{N}{m^2}$
- $= 120000 \text{ Nm}^{-2}$

Applications of Pressure in Liquids and Gases

1) A Syringe

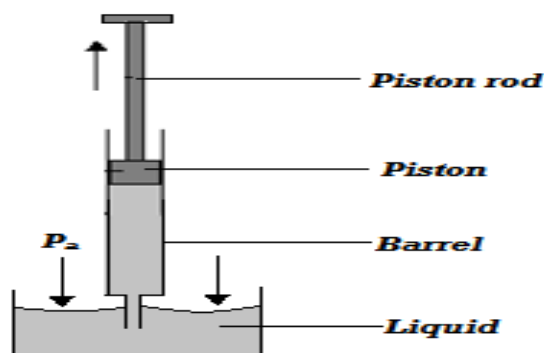

- ❖ When the piston is pulled upwards (during upstroke), space is created in the barrel thus lowering the pressure inside below atmospheric pressure. The higher atmospheric pressure acting on the liquid pushes the liquid into the barrel.
- ❖ During a down stroke, the pressure inside increases above atmospheric pressure and the liquid is expelled from the barrel.

2) The Bicycle Pump

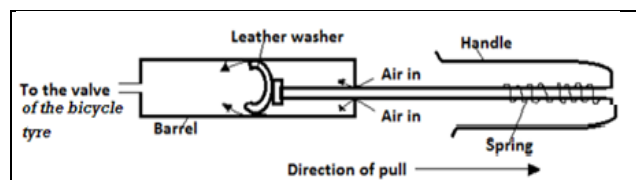

❖ The **leather washer** acts as both a **valve** and **piston** inside the pump barrel.

❖ When the **pump handle is drawn out** as shown, air in the barrel expands and its pressure reduces below the atmospheric pressure. Air from outside the pump then flows past the leather washer into the barrel. At the same time, the higher air pressure in the tyre closes the tyre valve.

❖ When the **pump handle is pushed in**, the air is forced into the tyre through the tyre valve which now opens.

Note: There is an increase in temperature of the pump barrel during pumping this is because of the work done in compressing air.

3) The Lift Pump

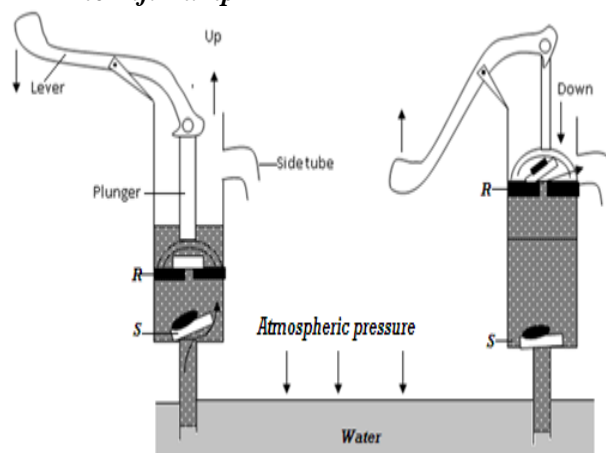

❖ To **start the pump**, water is poured on top of the piston so that good air tight seal is made round the piston and in valve P the pump is operated by means of a lever

Upstroke

❖ When the plunger moves up during the upstroke, valve R closes due to its weight and pressure of water above it. At the same time, air above valve expands and its pressure reduces below atmospheric pressure. The atmospheric pressure on the water in the well below thus pushes water up to past valve into the barrel.

❖ The plunger is moved up and downhill the space between R and S is filled with water.

Down stroke

❖ During down stroke, valve S closes due to its weight and pressure of water above it.

Limitations of the Lift Pump

- ❖ In practical, the possible height of water that can be raised by this pump is less than 10m because of
 - i) Low atmospheric pressure in places high above sea level,
 - ii) Leakage at the valves and pistons
- 4) ***The Force Pump***

This pump is used to raise water to heights of more than 10m.

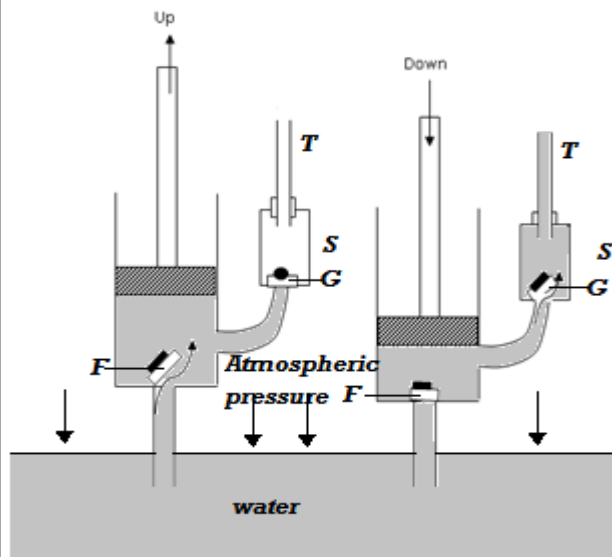

Upstroke

❖ During upstroke, air above the valve F expands and its pressure reduces below atmospheric pressure. The atmospheric pressure on water in the well pushes water up past valve F into the barrel. Pressure above valve G is atmospheric. Hence, this valve does not open in this stroke.

Down stroke

❖ During the down stroke, the valve F closes. Increase in pressure due to water in the barrel opens valve G and forces water into chamber S so that as water fills the chamber, air is trapped and compressed at the upper part. During the next upstroke, valve G closes and the compressed air expands ensuring a continuous flow.

Advantage of Force Pump over the lift pump

- a) It enables a continuous flow of water.
- b) The height to which it can raise does not depend on atmospheric.

Factors Affecting Working of the Force Pump

- a) Amount of force applied during the down stroke.
- ❖ Ability of the pump and its working parts to withstand pressure of the column of water in chamber
- c.

Exercise on applications of pressure

(a) *The figure below shows a lift pump*

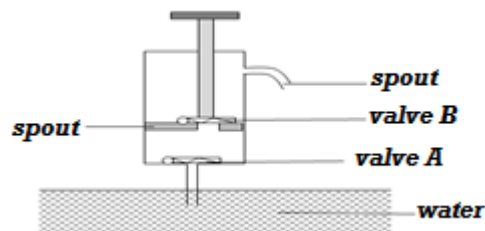

Explain why, when the piston is;

- (b) *Pulled upwards, valve A opens while valve B closes.*
- (c) *Pushed downwards, valve A closes while valve B opens*
- (d) *After several strokes, water rises above the piston as shown below.*

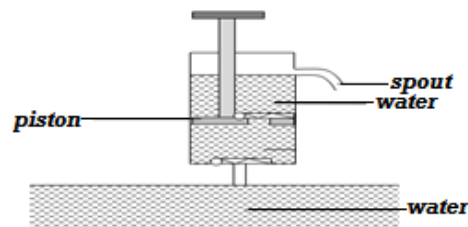

State how water is removed from the cylinder through the spout.

- (e) *A lift pump can lift water up to a maximum height of 10m. determine the maximum height to which the pump can raise paraffin.(take density of paraffin as 800kgm⁻³and density of water as 1000kgm⁻³)*
- (f) *State one factor that determines the height to which a force pump can lift water.*

Revision Exercise

1. A piston whose diameter is 1.4m is pushed into a cylinder containing a fluid, If the pressure produced in the cylinder is $4.0 \times 10^5 \text{ pa}$, Calculate the force applied on the piston.
2. An octopus is resting in the ocean. If the octopus is at a depth of 47m in sea whose water has a density of 1200 kg/m^3 , calculate the pressure experienced by the octopus (Take atmospheric pressure = $1.0125 \times 10^5 \text{ Pa}$)
3. Explain why if air gets in the brake system would reduce the efficiency of the brakes. (2marks)
4. A concrete block of mass 50kg rests on the surface of the table as shown below.

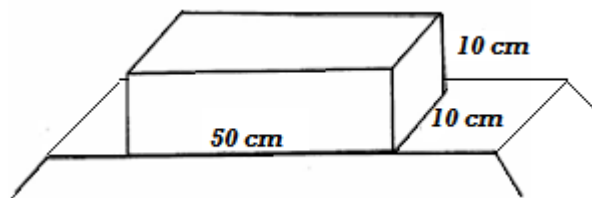

What is the maximum pressure that can be exerted on the bench by the block?

5. A hole of area 4.0 cm^2 at the bottom of a tank 5m deep is closed with a cork. Determine the force on the cork when the tank is filled with water. (Take $g = 10 \text{ ms}^{-2}$ and density of water = 1000 kgm^{-3}).
6. A measuring cylinder of height 25cm is filled to a height of 15cm with water and the rest is occupied by kerosene. Determine the pressure acting on its base (density of water = 1 gcm^{-3} density of kerosene = 0.8 gcm^{-3} and atmospheric pressure = $103,000 \text{ pa}$).
7. State one advantage of hydraulic brakes over mechanical brakes.
8. Explain why a lady wearing sharp heeled shoes is not likely to skid on a slippery muddy road.
9. Why does atmospheric pressure decrease towards higher altitude?
10. Show that Pressure in fluids is given by $P = h\rho g$
11. Give a reason why nose bleeding is likely to occur at the top of a mountain.
12. A block of glass of density 2.5 g/cm^3 has dimensions 8 cm by 10cm by 15cm. It is placed on one of its faces on a horizontal surface. Calculate:-
 - a) The weight of the block
 - b) The greatest pressure it can exert on the horizontal surface.
 - c) The least pressure it can exert on the horizontal surface.
13. The reading of a mercury barometer is 75.58 cm at the base of a mountain and 66.37cm at the summit. Calculate the height of the mountain (Density of mercury = 13.6 g/m^3 and density of air = 1.25 kg/m^3)
14. In a hydraulic brake, the master piston has an area of 4 mm^2 and the wheel piston each has an area of 4 cm^2 . Find the forces applied to the wheel when a force of 10N is applied on the master piston.

15. The figure below shows a hydraulic press

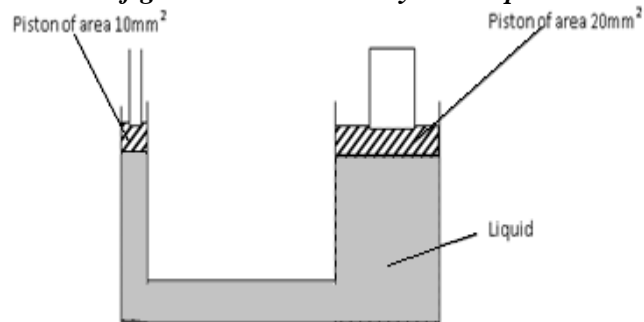

The two pistons are of areas 10 mm^2 and 20 mm^2 respectively. A force of 100N is applied on the smaller piston, find the load that can be lifted on the larger piston if:

- a. The piston has negligible weight and no frictional forces exist.
- b. The pistons have negligible weight and frictional 10N and 40N respectively.

The smaller piston has the weight 5N the larger piston has a weight of 10N and the frictional forces are negligible.

CHAPTER 5 PARTICULATE NATURE OF MATTER

Introduction

- ❖ Matter is anything that occupies space and has mass.
- ❖ Matter is not continuous but it is made up of every tiny particles hence particulate nature of matter.
- ❖ Particulate nature of matter therefore refers to the existence of matter in very tiny particles.

Experiment to demonstrate that Matter is made up of Tiny Particles

i) Use of a Piece of Paper

- ❖ A piece of paper can be cut continuously until when the small pieces cannot be cut into pieces any further. This suggests that the sheet of paper is made of tiny pieces of paper. Hence matter is made up of tiny particles.

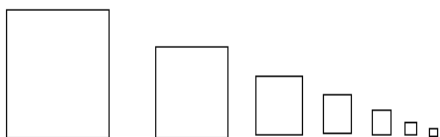

ii) Diluting Potassium Permanganate Solution

- ❖ The process of diluting purple potassium manganese (VII) can continue until the solution appears colorless.
- ❖ This suggests that the particles of potassium permanganate are spread evenly in water and each dilution process spread them further. This is a proof that matter is made up of tiny particles which can be separated.

Explain why it is possible to dissolve sugar in water without any noticeable increases in volume of water. The sugar particles occupy the small intermolecular spaces of water molecules. This behaviour of sugar suggests that matter is made up of very tiny particles.

Brownian motion

- ❖ Brownian motion refers to the random movement of liquid and gas particles.

To Demonstrate Brownian motion in Liquids

- ❖ Consider the set-up alongside in which chalk dust is sprinkled on the surface of water in the beaker and the beaker covered using a transparent lid. The behaviour of chalk dust is then observed with the help of a hand lens as shown below.

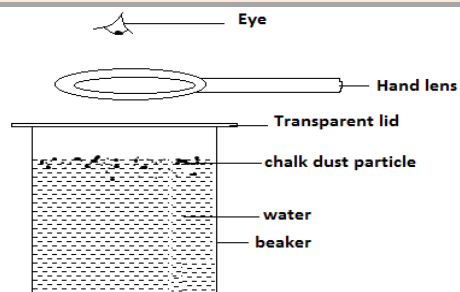

- ❖ The chalk dust is observed to be in constant random motion. This is due to the continuous collision of chalk dust particles with the water molecules which are in continuous random motion.

To Demonstrate Brownian motion in Gases (The Smoke Cell Experiment)

- ❖ Consider the set up below for the smoke cell experiment.

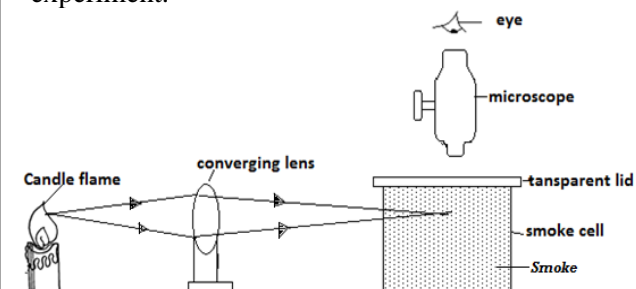

- ❖ **Note:** The smoke is introduced into the smoke cell by burning the straw and letting the smoke fill the smoke cell from the other end. Smoke is used here because smoke particles are light and bright.
- ❖ The converging lens is used to focus/ concentrate converge the light to the smoke cell thereby illuminating the smoke. The microscope assists the observer see the illuminated smoke particles clearly.
- ❖ The bright specks are observed moving randomly in the smoke cell. The bright specks are the smoke particles which scatter / reflect light shining on them. They move randomly due to continuous collision with invisible air particles which are in continuous random motion.

The Kinetic Theory of Matter

- ❖ The above experiments on Brownian motion constitute the kinetic theory of matter which states that matter is made up of tiny particles which are in continuous random motion.

Arrangement of Particles in Matter

Solids

- ❖ Particles are closely packed together in an organized manner and in fixed position.
- ❖ Particles in solid do not move randomly but instead vibrate about their fixed positions (vibratory motion) because of very strong intermolecular force (cohesive force). This explains why solids have *fixed volume and definite shape.*

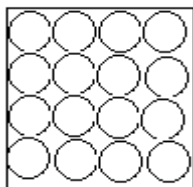

Liquids

- ❖ Particles in liquids are not closely fixed as in solids but move about randomly (Brownian motion). This is because the intermolecular forces in liquids are weaker than those in solids.
- ❖ The same reason explains why liquids have *no fixed shape* but assume the shape of the container.
- ❖ The intermolecular force in liquids is stronger than in gases a reason as to why liquids *have fixed volume* but gases don't.

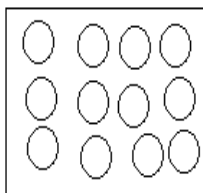

Gases

- ❖ Particles in gases are further apart and have an increased random motion compared to liquid particles.
- ❖ This is because of very weak intermolecular forces in gases particles as compared to liquids and solids. The same reason explains why gases have *no definite shape and volume.*

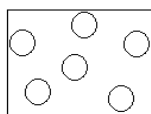

Example

Using a block diagram and correct terminology show how one state of matter changes to the other when the temperature is changed. Define all terminologies used.

- Melting**- is the process by which a solid changes to a liquid at fixed temperature.
- Evaporation** - is the process by which a liquid changes to a gas at any temperature.
- Condensation** - is the process by which a gas changes to a liquid at fixed temperature.
- Freezing** - is the process by which a liquid changes to a solid at fixed temperature.
- Sublimation** - is the process by which a solid changes to gas directly without passing the liquid state.
- Deposition** - is the process by which a gas changes to solid directly without passing the liquid state.

Diffusion

- ❖ **Diffusion** refers to the process by which particles spread from region of high concentration to a region of low concentration. Noticeable diffusion takes place in liquids and gases due to their continuous random motion.

Demonstrating Diffusion in Liquids

- ❖ Consider the set up below used to investigate diffusion in liquids. Concentrated copper (II) sulphate (blue in colour) is carefully and slowly introduced into the beaker through a funnel to obtain two layers.

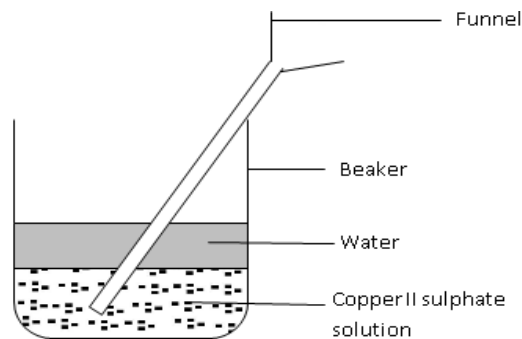

- ❖ After some time, it is observed that the boundary between the two liquids disappears and a homogenous pale blue mixture is obtained. This is because there is a greater rate of movement of water particles from the water layer to copper (II) sulphate layer. At the same time there is greater movement of copper (II) sulphate particles from the copper (II) sulphate layer to the water layer.
- ❖ **Note:** If hot liquids are used, formation of the mixture will be faster because the particles move faster due to increased kinetic energy.

Demonstrating Diffusion in Gases

- ❖ Consider the set up below used to demonstrate diffusion in gases

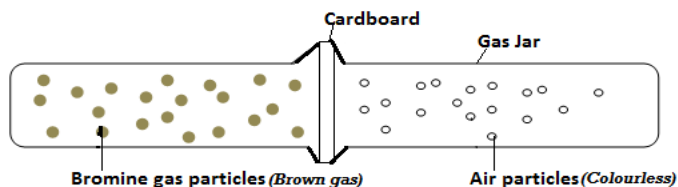

- ❖ When the cardboard is removed and the two jars pressed together, it is observed that a homogenous pale brown mixture forms in the two jars. This is because bromine gas spreads into gas jar containing air at a greater rate. At the same time air spreads into gas jar containing bromine at a greater rate.

- ❖ **Note:** Diffusion in gases is faster than in liquids because:

- Gases have low density.
- Gases have high kinetic energy.
- Gases very weak cohesive forces.

Rates of Diffusion of Gases

- ❖ Different gases have different rates of diffusion depending on *their density or relative masses*.
- ❖ A gas with a higher density has heavier particles and therefore its rate of diffusion is lower than the gas with lower density.

Example

- ❖ *In the figure below, ammonia gas and hydrochloric acid gas diffuse and react.*

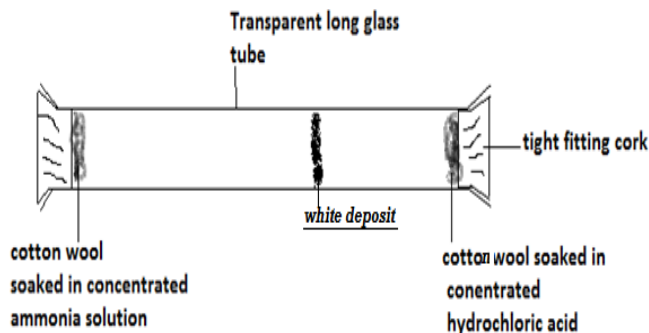

- State and explain the observation made after sometime.

- ❖ A white deposit is formed near the cotton wool soaked in concentrated in hydrochloric acid. The ammonia gas is less dense and has light particles thus it will diffuse faster than the hydrochloric acid which is dense.

- On the diagram, show the observation
- If the experiment was performed at a high temperature will you expect it to take longer or shorter time to form white deposit? Explain.

Shorter time. This is because an increase in temperature increases the kinetic energy of the particles of the gases and hence increased rate of diffusion of the gases.

Diffusion through Porous Materials

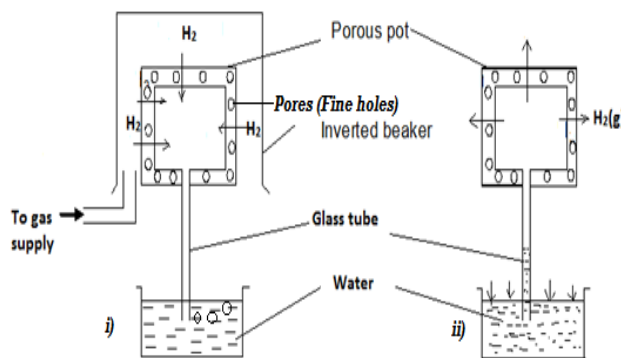

- ❖ Initially, hydrogen gas diffuses into the porous pots at a faster rate than air diffusing out. As a result, air bubbles out of water as shown in figure i).

- ❖ When the gas supply is stopped hydrogen gas diffuse out of the pot through the fine holes at a faster rate than air gets back into the pot. This decreases the gas pressure in the pot and as a result the higher atmospheric pressure acting on the water surface in the beaker to pushes water up the tube as in figure ii).

Note: The beaker is used to confine the hydrogen gas around the porous pot. It is obvious that air is denser than hydrogen gas.

REVISION EXERCISE

1. *What is matter?*
2. *With the aid of a diagram, describe an experiment that you would use to show that matter is made up of tiny particles.*
3. *During a class discussion, Emmanuel observed that Brownian motion was only exhibited by small particles.*
 - (a) *Is this observation correct?*
 - (b) *Explain your answer in (a) above.*
4. *State the kinetic theory of matter.*
5. *Distinguish between the three states of matter in terms of the intermolecular forces.*
6. *What factor determines the state of matter?*
7. *Explain why solids are not compressible while gases are.*
8. *Define Brownian motion.*
9. *During Brownian motion experiment, the smoke particles must be small and light. Explain why it is necessary that the particles be light.*
10. *Smoke is introduced into smoke cell which is then viewed under a microscope.*
 - (a) *What do you observe through the microscope?*
 - (b) *What conclusion can be drawn from this observation?*
11. *Temperature affects Brownian motion. Explain.*
12. *Lycopodium powder is lightly sprinkled on a clean water surface in a large tray. A red hot needle is plunged into the centre of the water surface. State and explain what is observed.*
13. *Define diffusion.*
14. *Describe an experiment to demonstrate the process of diffusion in;*
 - (i) *Liquids*
 - (ii) *Gases.*
15. *Name and explain the factors that affect the rate of diffusion in gases.*

Chapter Six

THERMAL EXPANSION

Definition

- ❖ Thermal expansion refers to increase in volume of a body when heated.

Temperature

- ❖ Temperature is the degree (extent) of hotness or coldness of a body on some chosen scale.
- ❖ Temperature is measured *using a thermometer* and it is a basic quantity whose **SI unit** is **the Kelvin**.
- ❖ Degree Celsius ($^{\circ}\text{C}$) is another unit in which temperatures can be measured.
- ❖ Temperature is a scalar quantity.

Thermometers

- ❖ A thermometer is an instrument used to measure temperature. There are many types of thermometers, each designed for a specific use.

Liquid-in-Glass Thermometer (Common Thermometer)

- ❖ The liquid commonly used in a liquid – in – glass thermometer is mercury. Alcohol can also be used.
- ❖ Note: A liquid used in thermometer is commonly known as thermometric liquid.

Features of a Liquid –In – Glass Thermometer

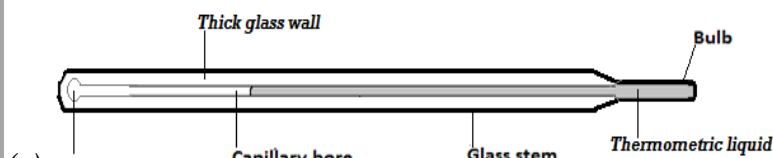

(a) A Bulb

- ❖ Contains the thermometric liquid. It is thin walled to increase sensitivity of the thermometer (i.e. allow quick transfer of heat).

(b) Capillary Bore

- ❖ It allows the liquid in the bulb to rise and fall when temperature changes.
- ❖ It has a small diameter to increase its accuracy so that a small change in temperature can easily be measured.

(c) Glass Stem

- ❖ It is made up of thick glass to strengthen the thermometer and therefore protect the liquid inside.
- ❖ Thick glass also acts as a magnifying glass to magnify the liquid thread.

Thermometric Liquids

- ❖ They include:
 - Mercury
 - Alcohol
 - Oil of creosote

Properties of a Good Thermometric Liquid

- It should not wet glass.
 - It should expand uniformly (regularly).
 - It should be a good conductor of heat.
 - It should be visible.
 - It should have high boiling point.
 - It should have low freezing point.
- ❖ Note: Water cannot be used as a thermometer liquid because:
 - It wets glass,
 - It expands irregularly (anomalously),
 - It is a bad conductor of heat,
 - It is invisible (colourless),
 - It has a relatively high freezing point.

Comparison between Mercury and Alcohol as Thermometric Liquids

Mercury	Alcohol
It has a high boiling point (357°C).	It has a low boiling point (78°C).
It has a relatively higher melting point (-39°C).	It has a low melting point (-115°C).
It is a good thermal conductor.	It is a poor thermal conductor.
It expands regularly.	Its expansion is slightly irregular.
It does not wet glass.	It wets glass.
It is opaque and silvery.	It is transparent and therefore has to be coloured to make it visible.

Notes

- ❖ Alcohol thermometer is the best for use in very cold conditions because its freezing point is very low (-115°C) but cannot be used in a very high temperature because its boiling point is relatively low (78°C).
- ❖ Mercury thermometers is best for use in high temperature because of its high boiling points (357°C) but cannot be used in very low temperature because it has a relatively high freezing point (-39°C).

Calibrating Liquid-in –Glass Thermometer

- ❖ A thermometer has two main fixed points:
 - I. The upper fixed point (100°C)
 - I. The lower fixed point (0°C)
- ❖ The upper fixed point is marked by putting the bulb of the thermometer in steam of water boiling at standard atmospheric pressure of 76 cmHg.
- ❖ The lower fixed point is marked by putting the bulb of the thermometer in pure melting ice.
- ❖ The range between upper fixed point and lower fixed point is sub divided into equal divisions of 1°C each.

The Celsius (Centigrade) and Kelvin (Thermodynamic Temperature) Scale

- ❖ The Celsius scale has fixed points at 0°C and 100°C while the Kelvin scale has fixed points at 273 K for pure melting ice and 373 K for steam or pure boiling water at standard atmospheric pressure.
- ❖ Temperature on Celsius scale and Kelvin scale are related by: $T(K) = \theta(^{\circ}\text{C}) + 273$.

Absolute Zero Temperature

- ❖ This is the lowest temperature on Kelvin scale in which the energy of the particles in a material is zero.
- ❖ Its value is zero Kelvin (-273°C).

Examples

- 3) Convert each of the following from Celsius to Kelvin (Hint: use $T(K) = \theta(^{\circ}\text{C}) + 273$.)
- a) -20°C
 $T = -20 + 273 = 253\text{K}$
 - b) 0°C
 $T = 0 + 273 = 273\text{K}$
 - c) 10°C
 $T = 10 + 273 = 283\text{K}$
 - d) -273°C
 $T = -273 + 273 = 0\text{K}$
- 4) Convert each of the following from Kelvin to $^{\circ}\text{C}$ (Hint: use $\theta(^{\circ}\text{C}) = T(K) - 273$.)
- a) 0K
 $\theta = 0 - 273 = -273^{\circ}\text{C}$
 - b) 167K
 $\theta = 167 - 273 = -106^{\circ}\text{C}$
 - c) 283K
 $\theta = 283 - 273 = 10^{\circ}\text{C}$
 - d) 3450K
 $\theta = 3450 - 273 = 3177^{\circ}\text{C}$

1) An uncalibrated mercury thermometer is attached to a cm scale which reads 14 cm in pure melting ice and 30cm in steam. If it reads 10 cm in freezing mixture, what is the temperature of the freezing mixture?

- o In melting ice, 14cm corresponds to 0°C
- o In steam, 30cm corresponds to 100°C
- o $\therefore 100^{\circ}\text{C} - 0^{\circ}\text{C}$ corresponds to $30\text{ cm} - 14\text{ cm}$
- o 100°C corresponds 16 cm length
- o 1 cm corresponds to $\frac{1\text{ cm} \times 100^{\circ}\text{C}}{16\text{ cm}} = 6.25^{\circ}\text{C}$
- o Temperature of the freezing mixture is:
 $0^{\circ}\text{C} + (10 - 14) \times 6.25^{\circ}\text{C} = -25^{\circ}\text{C}$

2) A faulty thermometer reads 18°C at ice point and 80°C at steam point. Determine the correct temperature when it reads 60°C .

- o At ice point, 18°C corresponds to actually 0°C
- o At steam point, 80°C corresponds to actually 100°C
- o $(80^{\circ}\text{C} - 18^{\circ}\text{C})$ corresponds to actually $(100^{\circ}\text{C} - 0^{\circ}\text{C})$
- o 62°C faulty corresponds to actually 100°C
- o 1°C faulty corresponds to actually $\frac{1^{\circ}\text{C} \times 100^{\circ}\text{C}}{62^{\circ}\text{C}} = 1.6^{\circ}\text{C}$
- o Correct temperature when faulty one reads 60°C is:
 $0^{\circ}\text{C} + (60 - 18) \times 1.6^{\circ}\text{C} = 67.2^{\circ}\text{C}$

Exercise

- 1) A faulty mercury thermometer reads 15°C when dipped into melting ice and 95°C when in steam at normal atmospheric pressure. What would this thermometer read when dipped into a liquid at 25°C
- 2) When marking the fixed points on a thermometer it is observed that at 0°C the mercury thread is of length 2cm and 9 cm at 100°C . What temperature would correspond to a length of 4cm?

Clinical Thermometer

- ❖ It is a special type of thermometer used for measuring human body temperature whose temperature range is about 35°C - 43°C .

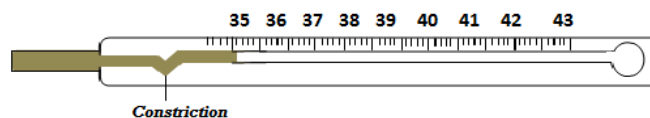

- ❖ The tube has a constriction which breaks the mercury thread for temperature reading to be taken.
- ❖ After the thermometer has been read the mercury is returned to bulb by a lightly shaking the thermometer.
- ❖ Methylated spirit is used to sterilize the thermometer after use.
- ❖ Note: clinical thermometer cannot be sterilized by boiling water because it will break since the boiling point of water is far above the temperature range of the thermometer.

Six's Maximum and Minimum Thermometer

❖ This thermometer records the maximum and minimum temperature reached in a place during a specified period of time, say a day.

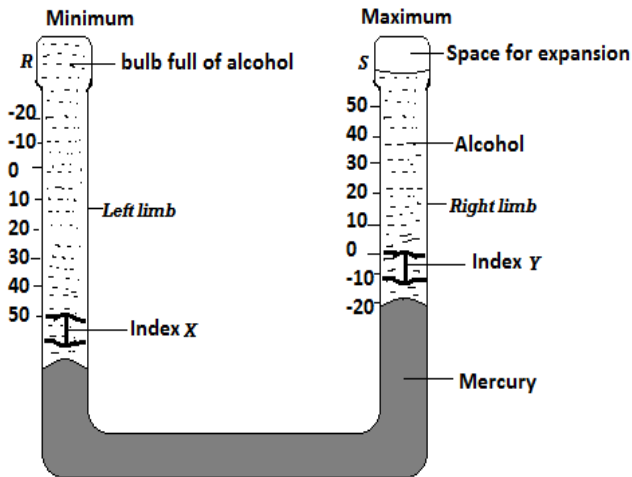

Mode of Operation of the Six's Thermometer

❖ When temperature rises, the alcohol in bulb R expands and pushes the mercury up the right limb of the u- tube. The mercury pushes index Y upwards. The lower end of this index indicates the maximum temperature reached during the specified period.

❖ When temperature falls, the alcohol in bulb R contracts and mercury is pulled back, rising up in the left limb. The index X is therefore pushed upwards. During contraction of alcohol, the index Y is left behind in the alcohol by the falling mercury. The minimum temperature is read from the lower end of index X.

To reset the thermometer, a magnet is used to return the steel indices to the mercury surfaces.

Expansion and Contraction of Solids

❖ When solids are heated they expand (increase in size/ volume) and when cooled they contract (decrease in size/ volume). Mass of the solid does not change when it contracts or expands.

❖ Density of the solid increases when the body is cooled (because volume decreases) and it decreases when the body is heated (because volume increases).

Experiments to Demonstrate Expansion and Contraction of Solids

1. The Ball and Ring Experiment

❖ The ball and ring experiment apparatus are as shown in the figure below. The ball just passes through the ring at room temperature and pressure.

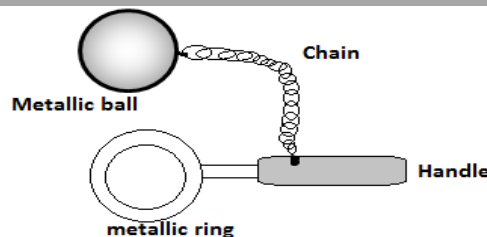

Observation: When the ball is heated, it does not pass through the ring but when it is left on the ring for sometimes it passes through. Explanation: When heated, the ball expands and so cannot go through the ring. When it is left on the ring for some time the temperature of the ball decreases and the ball contracts. At the same time the ring absorbs some heat from the ball its temperature increases and so it expands allowing the ball to pass through.

2. The Bar and Gauge Experiment

Question

In the figure below, at room temperature, the bar fits into the gauge.

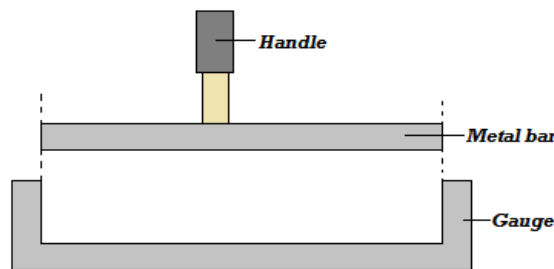

(a) *Explain what would happen when the bar is heated and you try to fit it in the gauge.*

The bar does not fit into the gauge because it expands when heated.

(b) *Consider a case where the bar is slightly bigger than the gauge at room temperature. Explain what you will do to make the bar fit into the gauge.*

Heat the gauge so that it expands and the bar will fit.

Comparing Expansion and Contraction of Different Metals

Question

An experiment was set to compare the expansion of different metals as shown below.

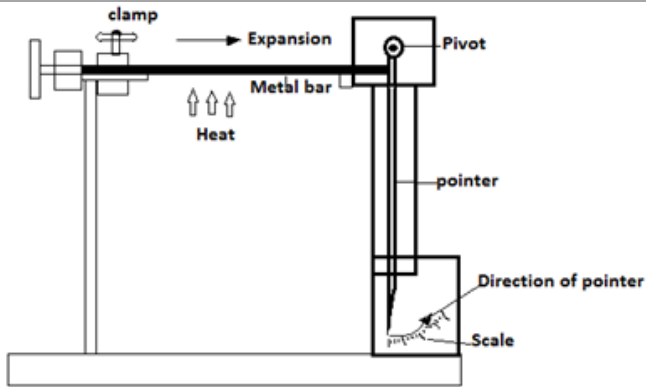

(a) Explain how the experiment works

o When the metal bar is heated it expands and pushes the pivoted pointer and the reading is taken on the scale. Metal bars of the same size made of different materials are attached to the clamp one at a time and heated for the same length of time. The readings on the scale are recorded and compared.

(b) What precautions should be taken to ensure fair result

- i) The metals should be of same length and diameter.
- ii) The metals should be heated using same burner. The metal should be heated for same length of time.

Linear Expansivity

- ❖ Linear expansivity is the tendency of a material to expand when heated. Different materials have different linear expansivities meaning that their rates of expansion or contraction are not the same except a few materials.
- ❖ The unit of linear expansivity is measured in *per Kelvin*. The following are some examples;

Material	Linear Expansivity (K^{-1})
Aluminum	26×10^{-6}
Brass	19×10^{-6}
Copper	16.8×10^{-6}
Iron	12×10^{-6}
Concrete	11×10^{-6}
Steel	11×10^{-6}

The Bimetallic Strip

- ❖ Bimetallic strip is made by riveting together two metals of different linear expansivities. The metal which expands at a higher rate when heated contracts faster when cooled.
- ❖ Consider a bimetallic strip made of iron and brass at room temperature and pressure in figure (a) below. Brass has a higher linear expansivity than iron and therefore expands at a faster rate than iron. When the strip is heated to a temperature greater than room temperature it bends towards iron as shown in figure (b) and when the strip is cooled, it bends towards brass as shown in figure (c) below.

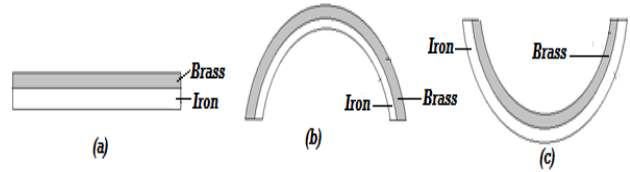

Example

The figure below shows a bimetallic strip at a room temperature ($25^{\circ}C$)

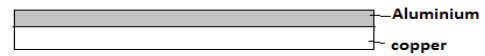

i) Draw the same bimetallic strip when at $90^{\circ}C$. Explain the observation.

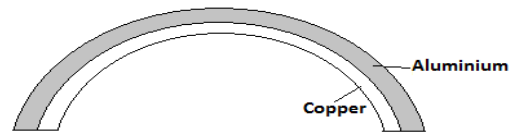

When temperature increases above room temperature aluminum expands at a faster rate than copper.

ii) Draw the bimetallic strip when at $-25^{\circ}C$. Explain the observation.

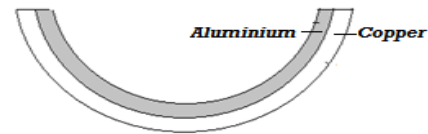

When temperature decreases below room temperature aluminum contracts at a faster rate than copper.

Applications of Expansion and Contraction of Solids

1) Expansion joints in Steam Pipes

- ❖ Pipes carrying steam are fitted with loops or expansion joints to allow for expansion when steam is passing through them and contraction when they are cooled. Without the loop the force of expansion and contraction will cause breakage of the pipes.

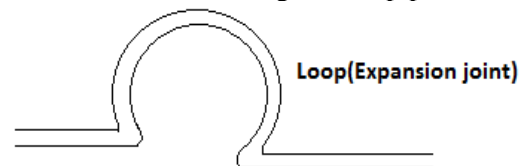

2. Fixing of Railway Line

- ❖ Railway lines are constructed in sections with expansion gaps and the sections held together by fishplates. The bolt holes in the rails are oval to allow free expansion and contraction of rails as the bolts move freely in the holes.
- ❖ A modern method of allowing for expansion and contraction in railways is to plane slant the rails so that they overlap.

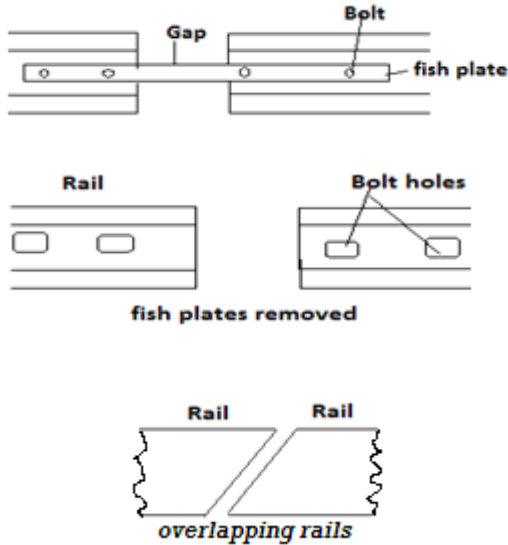

3. Fixing of Steel Bridges

- ❖ In bridges made of steel girders, one end is fixed and the other end placed on rollers to allow for expansion and contraction.

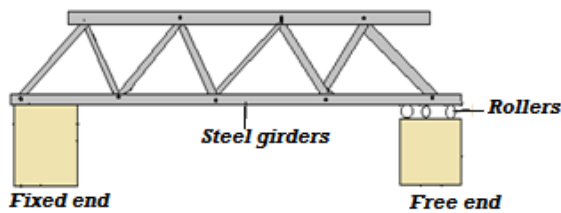

4. Rivets

- ❖ Thick metal plates in ships and other structures are joined together by means of rivets. A rivet is fitted when hot and then hammered flat. On cooling it contracts pulling the two plates firmly together.

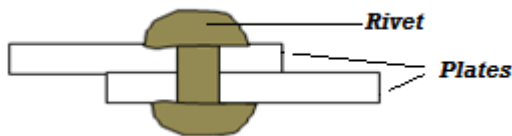

5. Installation of Telephone/ Electric Wires

- ❖ They are loosely fixed to allow for contraction. Telephone or electric wires appear to be shorter and taut in the morning. When it is hot, the wires appear longer and slackened.

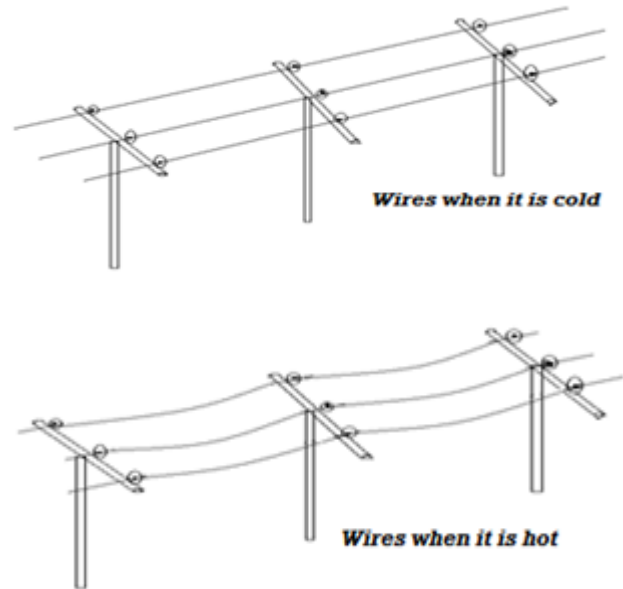

6. The Bimetallic Metal Application

- ❖ One of the most common application of a bimetallic strip is in the thermostat. A thermostat is a device for maintaining a steady temperature. The thermostat shown below is used for controlling the temperature of an iron box. A heater circuit is connected through the electrical terminals.

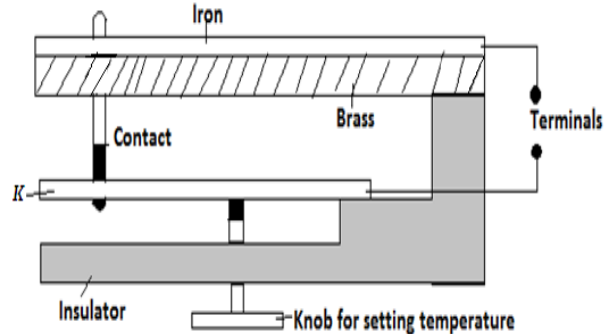

- ❖ If the iron box becomes too hot the bimetallic strip bends curving away from the lower contact. This breaks the contacts and switches off the heater. When it cools, the bimetallic strip bends closing up the gap between the contacts and the heater is switched on again.
- ❖ If the iron box is required to be very hot (i.e. high temperature), the setting knob is adjusted to push the metal K such that the contacts are tight together. For low temperature range the adjusting knob is released so that the position K is lowered.
- ❖ Thermostat is also used to control the temperature of electric cookers, electric heaters for warming rooms, and fridges.

Expansion and Contraction of Liquids

To Demonstrate Expansion of Liquids

- ❖ Consider the flask below filled with colored water as shown below.

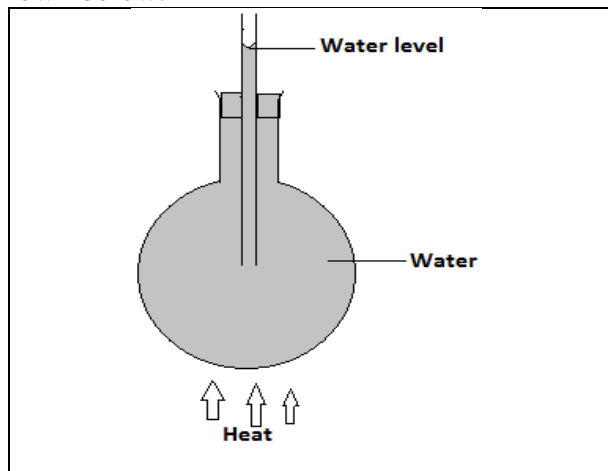

- ❖ When the flask is heated it is *observed* that water in the glass tube falls slightly and then starts rising.
- ❖ The initial fall of the water level in the tube is due to expansion of the flask which gets heated first. The water starts expanding when heat finally reaches it and it rises up the tube since liquids expand faster than solids.
- ❖ **Note:** Different liquids expand differently (i.e. they have different rates of expansion)
- ❖ If the above experiment was repeated using alcohol and then methylated spirit for the same length of time and using same heater, it would have been noted that methylated spirit expands most followed by alcohol and finally water.

Anomalous Expansion of Water

- ❖ Anomalous expansion of water is defined as the unusual behavior of water in which it contracts when heated and expands when cooled between 0 and 4°C.
- ❖ Consider heating ice from -8°C until it changes to water and its temperature increases to 8°C. A plot of volume verses temperature for the water is as in figure (a) while density verses temperature is as in figure (b) below.

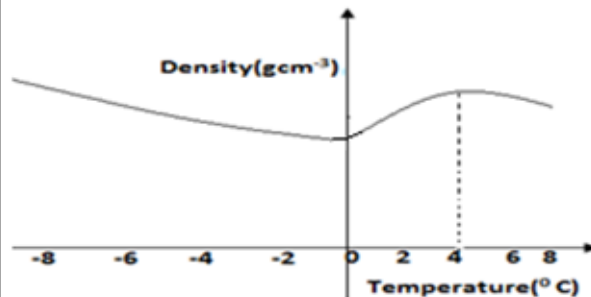
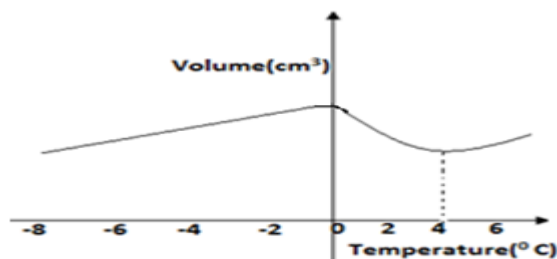

Effects of Anomalous Expansion of Water

1) Support Aquatic Life in Polar Countries During Winter

- ❖ During winter water freezes into ice. Ice being less dense than water floats on water. Since ice is a poor conductor of heat, it insulates the water below against heat loss to air above it.

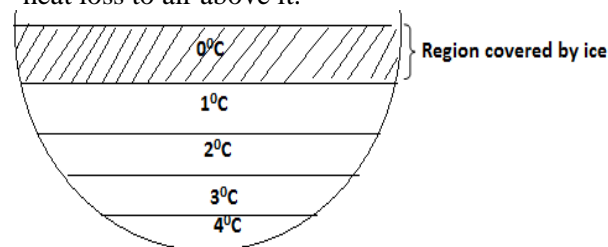

- 2) Anomalous expansion of water leads to formation of ice bags which pose a great danger to ships.
- 3) It causes weathering of rocks since when water trapped in freezes; it expands thus breaking rocks into small pieces.
- 4) It causes bursting of water pipes when water freezes in them.

Expansion of Gases

Experiment to Demonstrate Expansion and Contraction of Gases

- ❖ Consider the set up below which can be used to demonstrate expansion and contraction of gases.

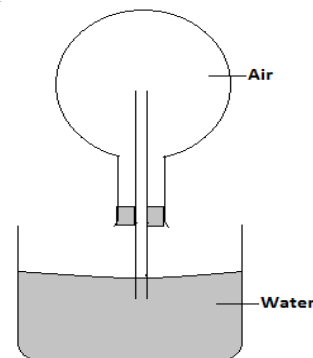

❖ *When the flask is warmed*, it is *observed* that the level of water column inside the glass tube drops indicating that the air has expanded. When the flask is warmed further, some bubbles are seen at the end of the tube in water as air escapes from the flask.

❖ *When the flask is cooled*, water level is *observed* to rise up the glass tube because the air inside the flask contracts to create space.

Examples

1) *The figure below shows a beam balance made out of concrete and reinforced with steel*



Use a diagram to explain the behaviour of the shape of the beam when heated up.



The beam expands linearly. The beam remains straight but longer than before heating. Both concrete and steel have same rates of expansion. Their value of linear expansivity is $11 \times 10^{-6} \text{K}$

2) *State two liquids which are used in thermometer. Alcohol and Mercury.*

3) *With a reason, state which of the two liquids in 3 (a) above is used to measure temperature in areas where temperatures are:*

(i) *Below -40°C alcohol, because it has a low freezing point of -115°C .*

(ii) *150°C , mercury, because it has a high boiling point of 357°C ,*

4) *What do you understand by the statement 'lower fixed point' on a temperature scale?*

This is the temperature of pure melting ice at standard/normal atmospheric pressure;

5) *Name two adaptations that can be made to a mercury thermometer to make it more sensitive.*

Using a thin walled bulb Using a narrower capillary tube

6) *The figure below shows a bimetallic strip made of brass and iron. A marble is placed at end A of the bimetallic strip as shown below:-*

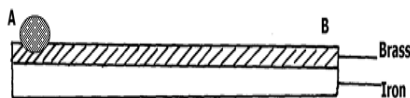

State and explain what will be observed when the bimetallic strip is strongly cooled

On cooling, the brass contracts more than iron, hence become shorter than iron and forms upwards curve, making the marble to roll and settle at the centre of the curve.

7) *The figure below represents a bimetallic strip of metals X and Y at room temperature*

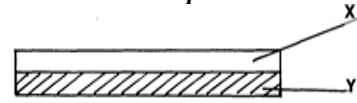

The figure below shows its shape when dipped into crushed ice



Sketch a diagram in the space given below to show the shape when the strip is heated to a temperature above the room temperature

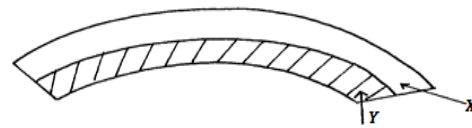

8) *Give a reason why a concrete beam reinforced with steel does not crack when subjected to Changes in temperature.*

Both concrete and steel have same rates of expansion. Their value of linear expansivity is $11 \times 10^{-6} \text{K}$

9) *Aquatic animals and plants are observed to survive in frozen ponds. Explain this observation.*

Water freezes and the ice formed floats in water because its density is less than that of water, insulating water below it. Temperatures increases down the pond because of anomalous expansion of water.

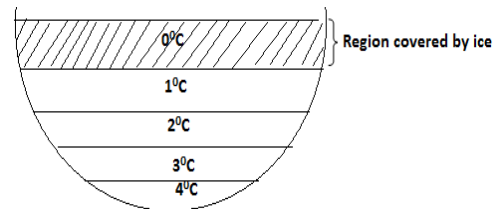

1. One property of a liquid that is considered while constructing a liquid in glass thermometer is that the liquid expands more than the glass for the same temperature change. State any other two properties of the liquids that are considered.
2. Give a reason why a concrete beam reinforced with steel does not crack when subjected to change in temperature
3. Explain why a glass container with thick walls is more likely to crack than one with a thin wall when a very hot liquid is poured into it.
4. Figure below shows a circuit diagram for controlling the temperature of a room.

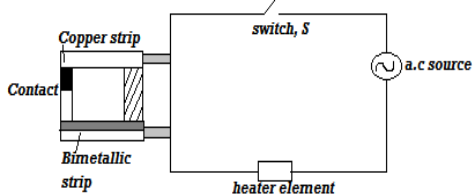

- i) State and explain the purpose of the bimetallic strip.
 - ii) Describe how the circuit controls the temperature when the switch S is closed.
5. Figure below shows a fire alarm circuit.

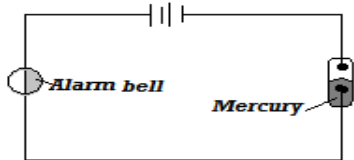

Explain how the alarm functions

6. Figure below shows a bimetallic strip at room temperature. Brass expands more than invar when heated equally.



Sketch the bimetallic strip after being cooled several degrees below room temperature

7. Figure below shows a bimetallic thermometer.

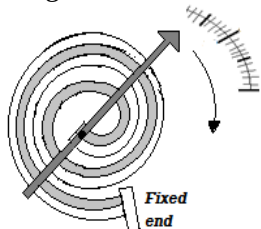

8. Figure below shows a flat bottomed flask containing some water. It is heated directly with a very hot flame. Explain why the flask is likely to crack.

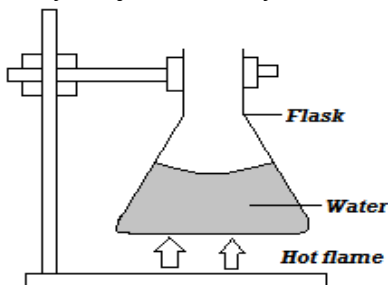

**This is a Property of Mwalimu
Consultancy Ltd. Contact Mr Isaboke
0746-222-000 for more Educational
Materials.**

Chapter Seven

HEAT TRANSFER

Definition of Heat

❖ Heat is a form of energy which flows from a point of higher temperature to another point of low temperature.

Differences between Heat and Temperature

HEAT	TEMPERATURE
Form of energy that flows due to temperature difference.	Degree of hotness or coldness of a body in some chosen scale.
The flow of heat cannot be measured precisely.	Can be measured accurately using a thermometer.
SI unit and joules (J).	SI unit is Kelvin (k).

Modes of Heat Transfer

❖ There are three modes of heat transfer: conduction, convection and radiation.

Conduction

❖ Conduction is the transfer of heat within an object without the movement of the object as a whole.

Mechanisms of Heat Conduction

- (a) Vibration of molecules
- (b) Through free electrons

Classification of Materials In Terms of Conduction

❖ Materials can be classified as good or poor conductors in terms of heat conduction.

(a) Good Conductors

Good conductors are materials that can allow heat to pass through them e.g.

- Copper
- Silver
- Aluminium
- Brass
- Mercury
- Iron
- Zinc
- Tin
- Lead etc.

(b) Poor Conductors (Insulators)

❖ These are materials which do not readily allow heat to pass through them e.g.

- Wood
- Air
- Water
- Rubber
- Plastic
- Glass

Example

The figure below shows pieces of wood and iron of equal length and diameter maintained in contact by a sheet of paper. A flame is then passed over the paper several times.

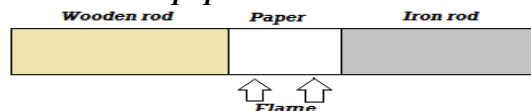

State and explain the observation made:

The paper gets blacked on the region covering the wooden rod. This is because wood is a poor conductor of heat and therefore does not conduct heat from the paper and therefore the paper burns. Iron is a good conductor of heat and conducts heat away from the paper.

Factors Affecting Thermal Conductivity

1. Nature of Materials

- ❖ Nature of material means what the material is made of.
- ❖ Consider the set up below.

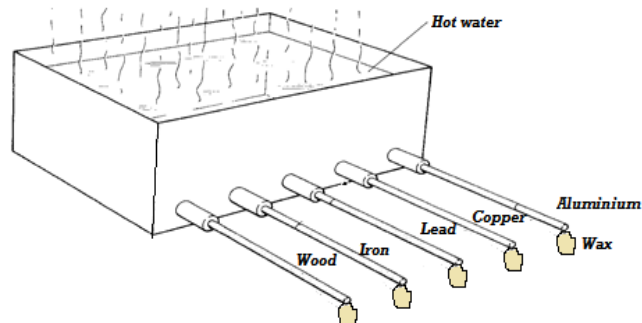

❖ It is observed that the wax attached to copper drops first followed by that on aluminum, iron lead and that of wood did not drop since wood is a poor conductor.

Precautions

- (a) Rods of same diameter to be used.
- (b) Rods equal length to be used.
- (c) Wax of the same size to be used.

2. The Thickness/ Diameter/ Cross Section Area of the Conductor

❖ Consider the set up below;

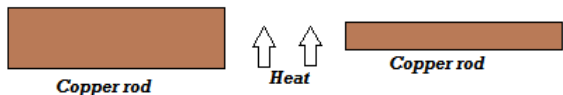

❖ It is *observed* that the wax on the thicker iron rod drops first. This is because more heat flows through a thicker conductor per unit time.

❖ Therefore, conductivity of conductors increases with thickness of the conductor.

Precautions

- (a) Equal time of exposure of the rods to heat.
- (b) Equal length and type of rods used.
- (c) Same size of wax used.
- (d) Rods placed at equal distances from the heat source.

3. Temperature Difference

❖ Consider the set ups A and B below.

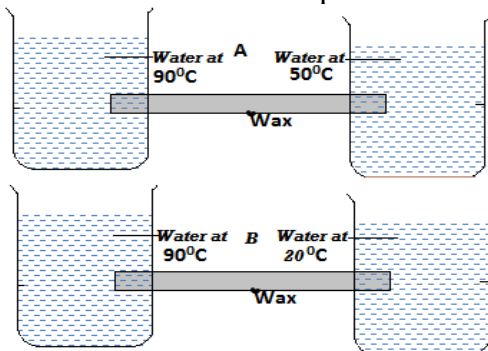

❖ It is *observed* that wax in set up B dropped first because of greater temperature difference than in A. Therefore, heat is transferred faster when temperature difference is greater.

Precautions

- (a) The rods of equal diameter used.
- (b) Rods of equal length used.
- (c) Wax of same size used.
- (d) Wax placed at equal distance from one end of the rod in each case.
- (e) Rods of same material used.

5. Length of the Conductor

❖ Consider the set up below;

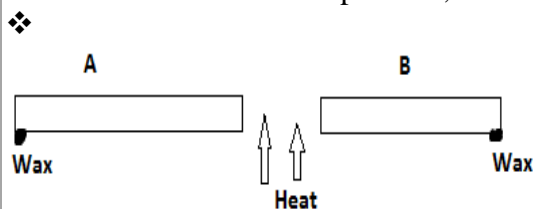

❖ It is observed that wax on rod B dropped first. Therefore, thermal conductivity increases with decrease in length of the conductor.

Precautions

- (a) Rods placed at equal distance from heat source.
- (b) Rods of same material used.
- (c) Wax of the same size used.
- (d) Rods of same thickness used.

Lagging

❖ Lagging refers to the covering of a good conductor of heat with an insulating material to reduce heat loss through surface effects.

❖ Consider the set up below;

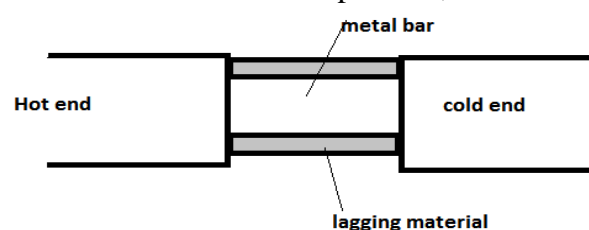

❖ Plots of temperature variation from the hot end to the cold end with lagging and without lagging on same axes will be as follows;

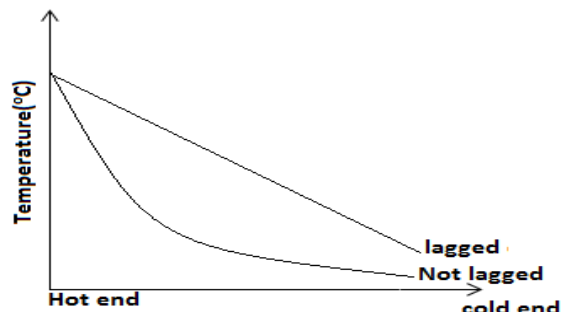

Applications of Lagging

❖ Iron pipes carrying steam from boilers or steam wells are covered with thick asbestos material which is an insulator to reduce heat loss from steam.

Thermal conductivity In Liquids

❖ Liquids are generally poor conductors of heat.

To Demonstrate that Water is a Poor Conductor

Experiment 1

❖ Consider the set up below for demonstrating that water is a poor conductor of heat.

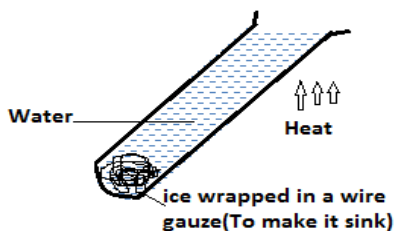

❖ After sometimes it is observed that water at the top of the tube boils while the ice remained unmelted. Water is a poor conductor of heat. Glass used for making test tube is also a poor conductor of heat.

Experiment 2

❖ Another experiment than can be used to show that water is a poor conductor of heat is as shown below.

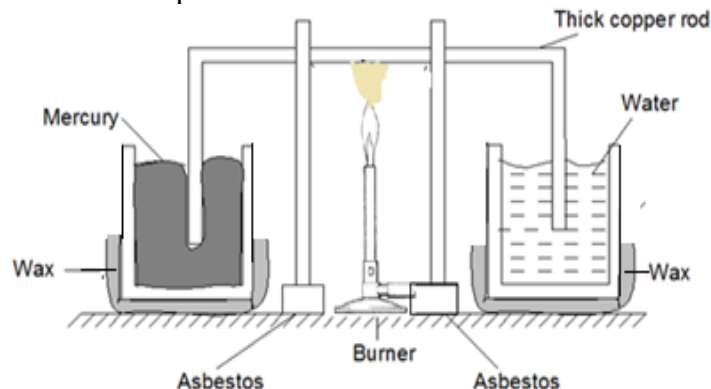

❖ It is observed that the wax coating on beaker containing mercury melted while that on beaker containing water did not melt. This is because mercury is a good conductor of heat while water is a poor conductor heat.

Thermal Conductivity in Gases

❖ Gases are poor conductors of heat. The set up below can be used to support this fact.

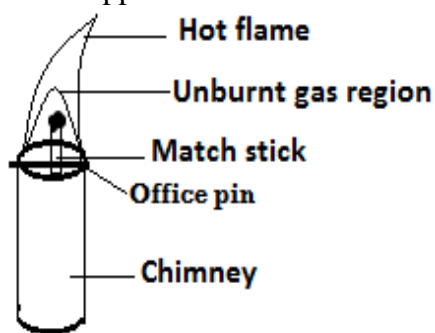

❖ It is observed that the match stick held within the unburnt gas region does not get ignited because gas is a poor conductor of heat.

Applications of Good and Poor Conductors of Heat

- (a) Cooking utensils and boilers are made of metals that conduct heat rapidly while their handles are made of insulators (poor conductors).
- (b) Modern buildings are made of double walls with an insulator between the walls to minimize heat loss from the house and therefore maintain stable temperature.
- (c) Fire fighters put on suits made of asbestos which is a poor conductor of heat to keep them safe while putting off fire.
- (d) Birds flap their wings after getting wet to introduce air pockets within their feathers this helps to minimize heat loss from their bodies.
- (e) In experiments involving heating liquids in glass vessel. The vessel is placed on a wire gauge because the gauge is a good conductor of heat it therefore spreads the heat to a large area of the vessel.

Convection

❖ Convection is the process by which heat is transferred through fluids.

To Demonstrate Convection in Liquids

Experiment 1

❖ Consider the diagram below in which potassium permanganate crystal is put at one corner in a beaker containing water and the beaker heated at that point.

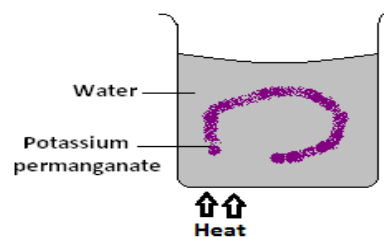

❖ After sometime, it is observed that a purple coloration rises up from potassium permanganate forming a circular loop. This is due to creation of convection currents in water.

Experiment 2

Consider the set up below

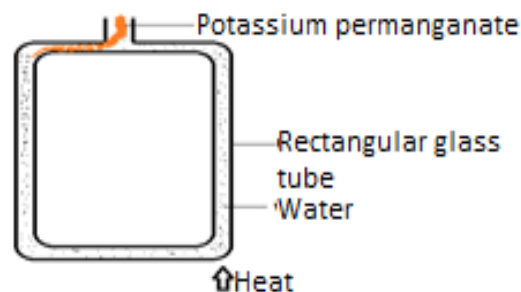

- ❖ It is observed that the purple colouration of potassium permanganate moves in the anti-clockwise direction in the tube. This is due to creation of convection current by heat whose direction is anti-clockwise

Convection in Gases

- ❖ Consider the set up shown below.

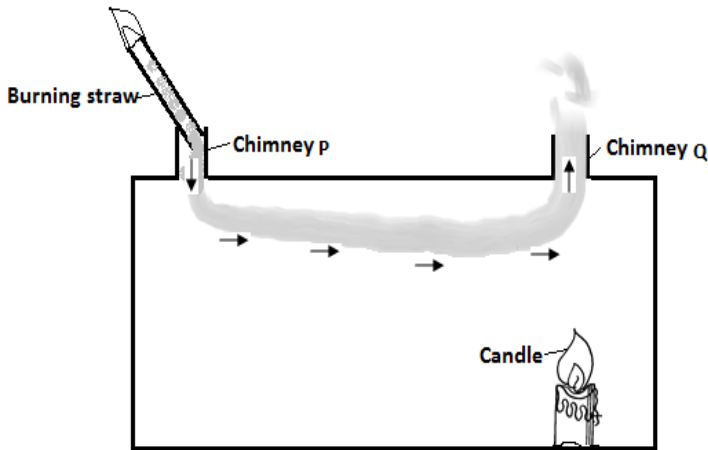

- ❖ It is observed that the smoke is sucked into the box through chimney P and exits through chimney Q. This is due to convection currents which are set up when the air in the box is heated.

APPLICATIONS OF CONVECTION IN FLUIDS

1. Ventilation

- ❖ Ventilation refers to the supply of fresh air to the room.

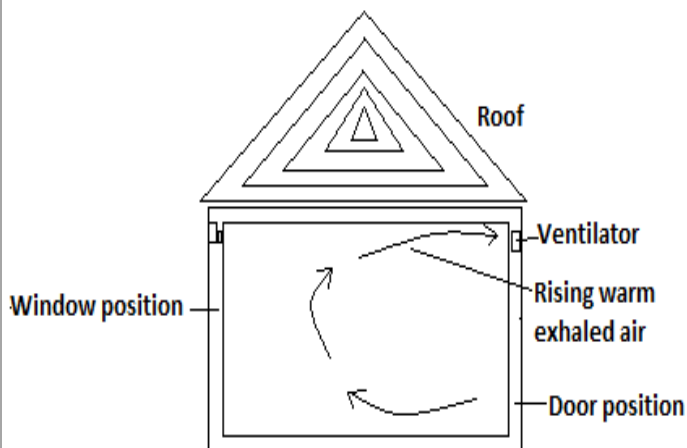

- ❖ Warm air exhaled by the occupants of the room rises and gets out through ventilators since it is less dense. Fresh cold air flows into the room through windows and doors. This way convection current is set up and there is always supply of fresh air.

2. Engine Cooling System

- ❖ Engine cooling is enhanced by both conduction and convection processes.

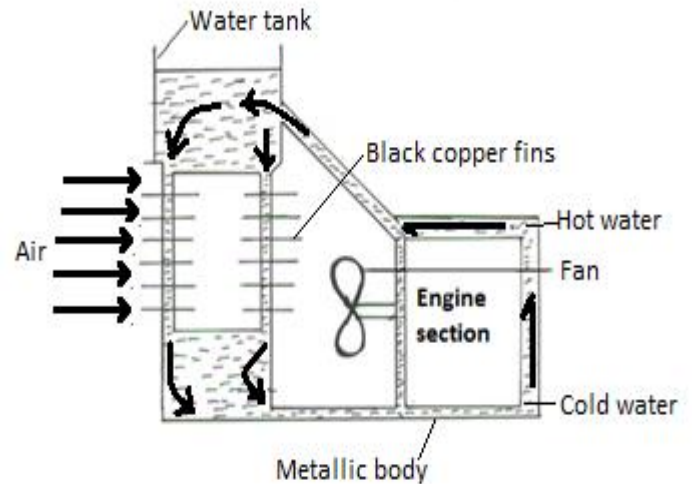

- ❖ The metal surface conducts away heat from engine. This heats up the water setting up convection currents which circulates as shown in the diagram.
- ❖ The hot water is pumped into the radiator which has thin copper fins that conduct away heat from the water.
- ❖ The fins are made of copper because it is the best conductor of heat. They are painted black because a black surface is a good absorber of heat.
- ❖ Fast flowing air past fins speeds up the cooling process.

3. Domestic Hot Water System

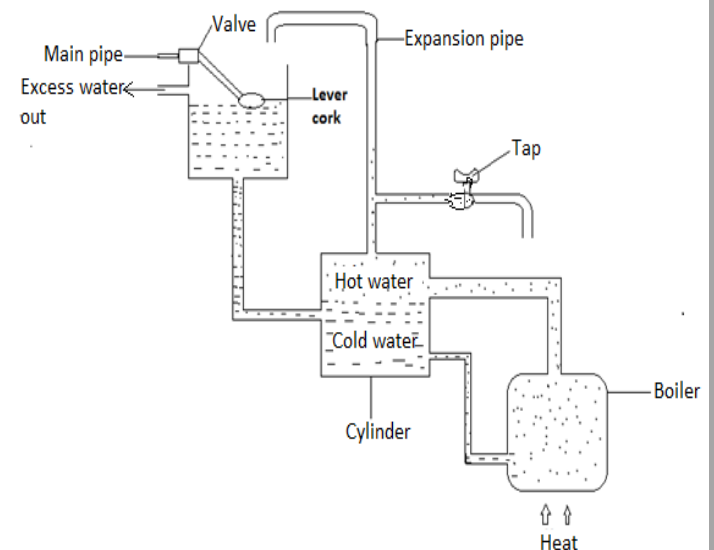

- ❖ **Hot water** rises up because of the lowering of its density when heated.
- ❖ **Cold water** move down from the cold water tank to the boiler because it is relatively heavier.
- ❖ **The expansion pipe** has an outlet for excess water that could have resulted from overheating
- ❖ The pipe that conveys the hot water and the cylinder are **lagged** to **minimize heat losses**.

Thermal Radiation

- ❖ Thermal radiation is the process by which heat is transferred through vacuum. In thermal radiation therefore matter is not involved in transfer of heat
- ❖ It is through this process of radiation that radiant heat reaches the earth's surface from the sun.
- ❖ The higher the temperature of a body the more the amount of thermal radiation.

Absorption and Emission of Radiant Heat

- ❖ A good absorber of radiant heat is also a good emitter of radiant heat while a poor absorber of radiant heat is also a poor emitter of the heat.
- ❖ Consider the set up below.

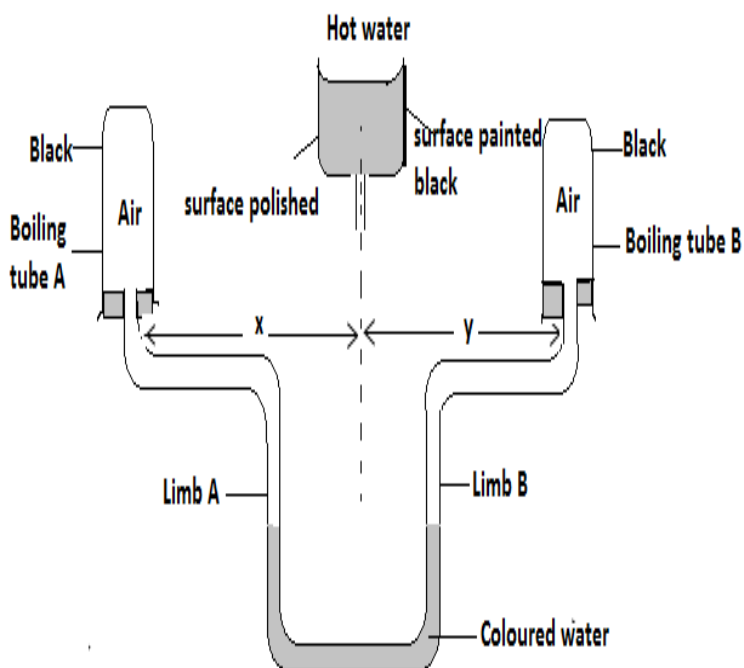

- ❖ It is **observed** that water level in limb A rises up while that in limb B falls. This is because boiling tube B receives more heat than boiling tube A warming the air inside it more. The air expands and therefore pushes down the water in limb B. As a result water level in limb A rises.

Application of Thermal Radiation

1. Solar Heater

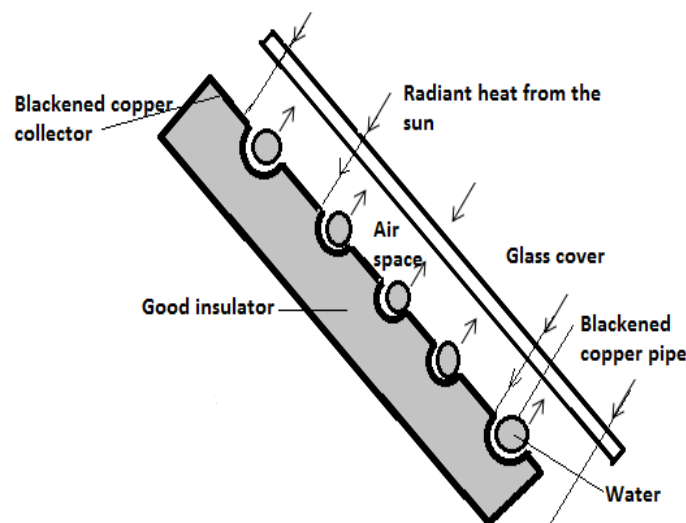
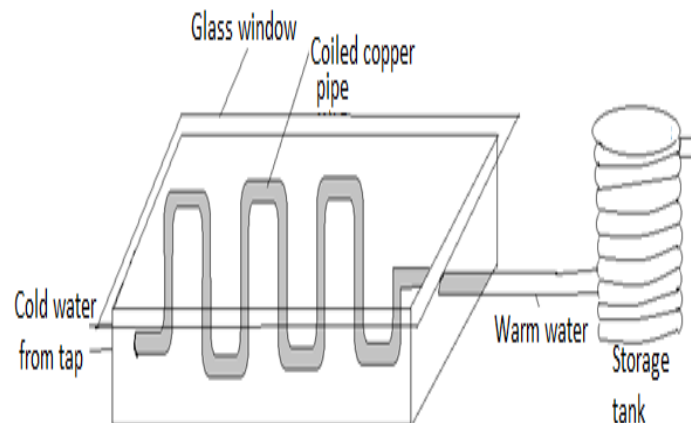

- ❖ **Copper pipe** is used because it is a good conductor of heat and will conduct heat into the water inside the pipe. It is painted black colour is a good absorber of heat.
- ❖ **The glass cover** allow radiant heat from the sun to pass through and prevents the weaker energy emitted after.
- ❖ **The black copper collector** absorbs heat energy and conducts it to copper pipes which transmit it to the water.
- ❖ **The insulating material** prevents heat from being lost from the pipe.
- ❖ **The copper pipe** is coiled severally to increase surface area for absorption of heat.

2. Thermos Flask

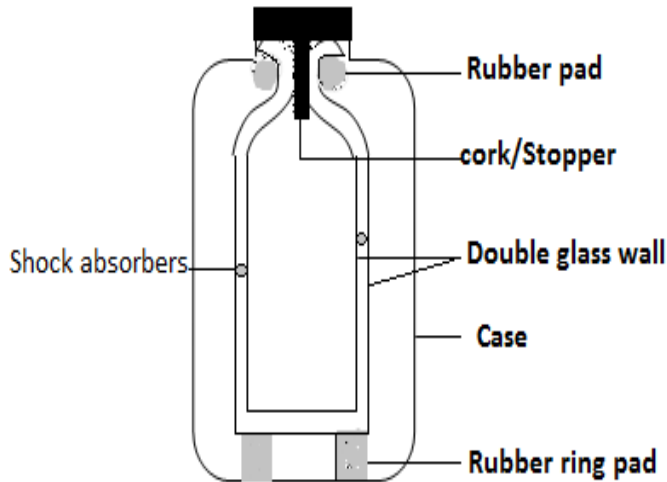

- ❖ The stopper rubber pad and rubber ring pad prevent heat loss through **conduction** since rubber is a poor conductor of heat
- ❖ Silvered wall prevents heat loss through **radiation** since the shiny surface is a poor radiator and emitter of heat.
- ❖ Vacuum prevent heat loss through **conduction** and **convection** since the two modes of heat transfer require material medium for transfer of heat.
- ❖ Shock absorber prevents breaking of the glass walls due to pressure from the outside.
- ❖ Vacuum seal prevents air from reoccupying the vacuum. It is through the vacuum seal that air was sucked out.

3. Green House Effect (Heat Trap)

- ❖ Green house effect is a phenomenon in which heat is allowed to pass through a transparent material but does not penetrate to the outside. This way heat accumulates in the green house continuously.
- ❖ Green houses are used to provide appropriate conditions in plants especially in cold areas.

4. Solar Concentrators

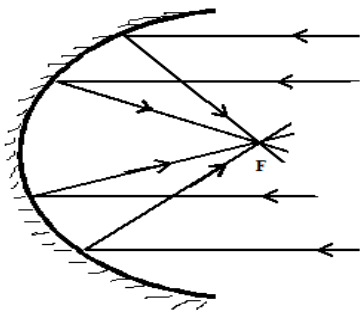

- ❖ Concave reflector is used to reflect radiant heat from the sun into a common point (focus). Temperature at this point is very high therefore the concentrated heat can be used for purposes like heating water.

6. Houses in hot areas have their walls and roofs painted with bright colours to reflect away heat while those in cold areas have walls and roofs painted silvery bright to reflect as much heat as possible back to the house.

7. Kettle, cooking pans and iron boxes have polished surfaces to reduce heat loss through thermal radiation

Revision Exercise

1. Two similar open tins with equal amounts of water at 80°C were left to cool. If tin A is shiny and tin B is blackened, sketch on the same axes the graphs of temperature against time for the two tins.

2. The figure below shows a box with two glass tubes A and B projecting from the top of a rectangular wooden box with removable glass front.

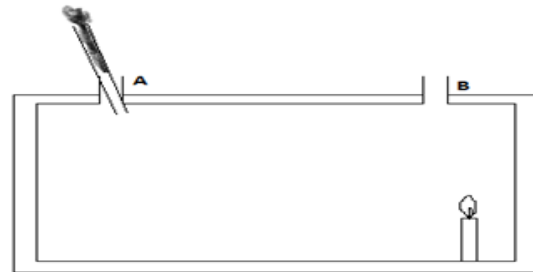

- (i) What will be the direction of the smoke through the box?
- (ii) What conclusion can be made from the observation?
- (iii) Why are the ventilations for a room made high up the roof?

3. Study the set up below and use it to answer the questions that follows:

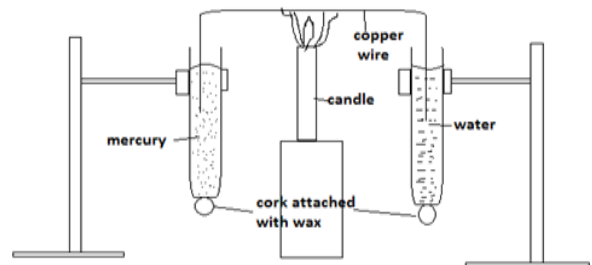

- (a) What does the experiment illustrates?
- (b) What two factors should one consider when selecting the rod to be used?
- (c) State the observations made in this experiment.

4. Explain the Greenhouse effect.

5. Name two examples of greenhouse gases.

1. The diagram below shows the essential features of a solar heating panel. A small electric pump circulates the liquid through the pipes.

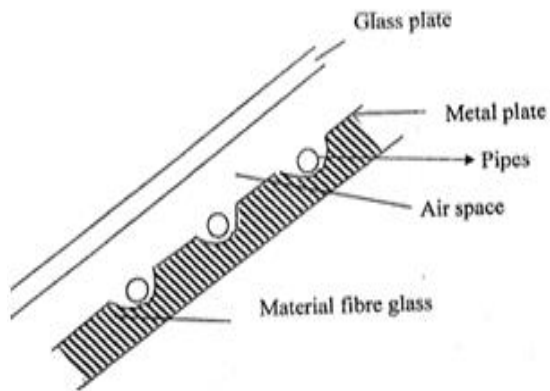

State briefly why:

The pipes and metal plates are blackened.
There is a material fibre glass on the panel.

2. The figure below shows an electric iron.

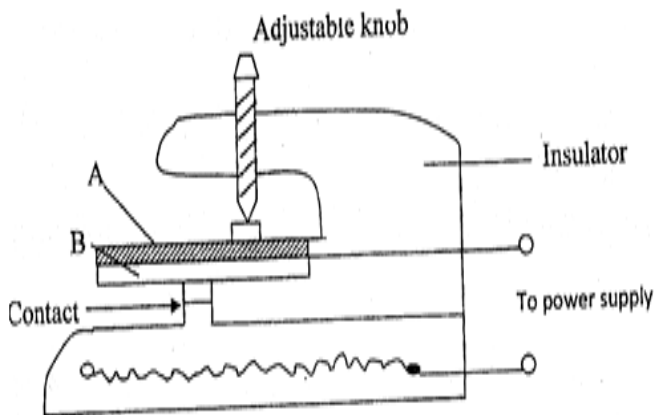

Two

metal plates A and B are riveted to form a bimetal strip as used above.

(i) Which metal expands more

(ii) Explain how the electric iron works when the power is on

CHAPTER 8

ELECTROSTATICS**Introduction**

- ❖ **Electrostatics** is a branch of physics that deals with static electricity which is a non-moving electric charge on the surface of an object.
- ❖ All substances are made of atoms. Atoms have three sub-atomic particles namely:
 - ✓ Protons
 - ✓ Neutrons
 - ✓ Electrons
- ❖ Protons have a positive charge. Electrons have a negative charge. Neutrons do not have any charge (i.e. they are neutral).

Types of Charges

- ✓ Positive charge(s). These charge(s) are obtained when an atom loses an electron(s).
- ✓ Negative charge(s). These charge(s) are obtained when an atom gains an electron(s)
- ❖ The SI unit of charge is ***the coulomb, C***.
- ❖ A charged atom (positively or negatively) is called an **ion**.
- ❖ A body that has neither a negative charge nor a positive charge contains an equal number of protons and electrons (Neutral atom). When these charges are equal in number, a body is ***electrically neutral***.

Electrostatic Charges of a Material

- ❖ A hard rubber rod gains millions of electrons when it is rubbed with a wool cloth. The cloth loses electrons to the rod and becomes positively charged. The rubber becomes negatively charged.
- ❖ When glass rod is rubbed with fur, the fur loses electrons to the glass rod. Glass rod becomes negatively charged and fur becomes positively charged.
- ❖ A body is said to be ***positively charged if*** it has an excess of positive charges or it has lost some electrons.
- ❖ A body is said to be ***negatively charged if*** it has an excess of electrons i.e. If it has gained some electrons.
- ❖ The following materials becomes negatively charged by friction when rubbed:
 - ✓ Polythene
 - ✓ Most plastics
 - ✓ Ebonite
- ❖ The following on the other hand becomes positively charged when rubbed:
 - ✓ Acetate
 - ✓ Perspex
 - ✓ Glass
 - ✓ Fur

The Basic Law of Electrostatics

- ❖ It states that **like charges repel, unlike charges attract**.

1. Two balloons inflated with air are tied with strings and held 1 metre apart. Both balloons are rubbed with fur. Why do the balloons move apart when brought close together?

2. For each situation below state whether the force between them is repulsive or attractive.



a) **Conductors and Insulators.**

- ❖ Substances which do not allow electrons to pass through them are called ***insulators***.
- ❖ Substances which allow electrons to pass easily through them are called ***conductors***. The reasons why they (metals) conduct easily is because within any metal some electrons are not attached to specific atoms but are free to wander about.
- ❖ If you were to hold a metal rod and rub it with wool would it be charged? **NO** However if you fit polythene handle onto the metal rod it can be charged by rubbing it. We explain this by saying that the polythene is an insulator and will not allow electrons to move through it on along its surface. When an insulator is rubbed, the electrons which are transferred come from atoms on the surface. The metals become charged by electrons from the wool. But if the metal is directly held, these electrons immediately **'leak'** away to the earth through the hand on the body whereas when the handle is insulated they remain on the metal because they cannot pass through the insulating handle.

Charging Methods

The following methods are used to charge materials:

- (a) Induction
- (b) Contact
- (c) Separation

(a) Induction

Charging polystyrene ball negatively by induction

- ❖ Suspend the polystyrene ball coated with aluminium using dry silk thread.
- ❖ Bring a positively charged glass rod close to but not touching the suspended ball.

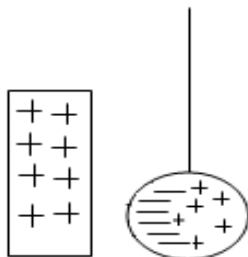

Note: The positive charges are repelled while the negative charges are attracted to the rod.

- ❖ Touch the side of the ball away from the glass rod with the finger.

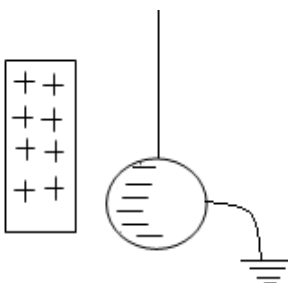

Note: Electrons flow from the earth to neutralize the positive charge on the ball.

- ❖ While holding the glass rod near the ball, withdraw the finger and then the glass rod.

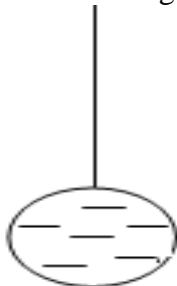

Note: The remaining negative charges redistribute themselves uniformly on the ball.

- ❖ When a body is charged by induction, it acquires the charges that are opposite to the inducing charge.

Question:

Explain by use of diagrams how the above material can be charged positively by induction method.

(b) Contact method

- ❖ Suspend the polystyrene ball coated with aluminium using dry silk thread.
- ❖ Bring a charged glass rod close to but not touching the suspended ball.

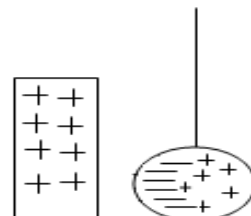

- ❖ Bring a charged glass rod in contact with the ball, rolling it over the surface.

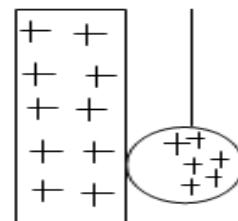

- ❖ Withdraw the charged rod.

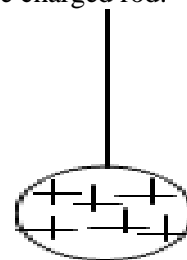

Notes

- a) When a positive rod is rolled on the ball, some of the negative charges induced in the ball are neutralized by some positive charges on the rod.
- b) When the rod is withdrawn, the positive charges redistribute themselves all over the surface of the rod.
- c) When a body is charged by contact method, it acquires charges that are similar to the ones on the charging rod.

Question: Explain how a material is charged negatively by contact method

(c) Separation Method

- ❖ Place two spheres A and B together so that they form a single conductor.
- ❖ Bring a charged polythene rod close to but not

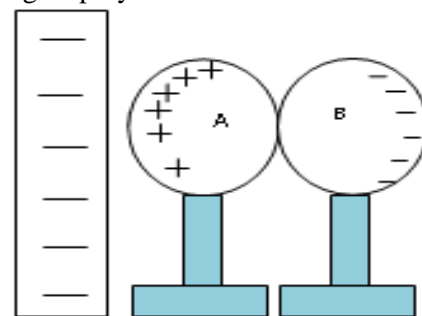

touching sphere A.

- ❖ Move sphere B away so as to break the contact, while holding the charged rod in position.

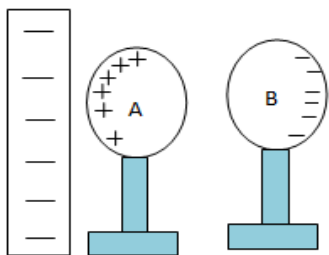

- ❖ Withdraw the charged rod and test the two spheres using a negatively charged rod for the presence and type of charge in each sphere.

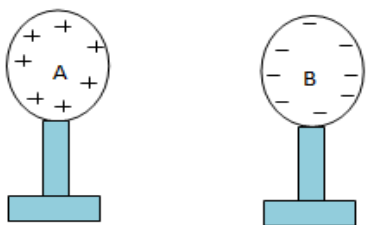

- ❖ It consists essentially of a metal cap (brass) and rod (boast) at which is connected a piece of very thin metal foil called the leaf (sometimes gold foil, aluminum) supported with a piece of insulating material (could be cork, cellulose acetate) which forms part of a box with glass slides.
- ❖ **The metal casing** protects the leaf from the effect of the draught.
- ❖ **The glass window** is transparent for observation to be made.
- ❖ **The rod** is supported by a plug of good insulators which stops charges given to the cap from spreading to the case and hence **leaking away**.
- ❖ **The cap** is circular to ensure uniform distribution of charge on it.
- **Earthing**-Process of losing charges to or gaining charges from the earth through a conductor. Represented by the symbol:



Charging a Gold Leaf Electroscope by Contact

- ❖ An electroscope is charged negatively by bringing a charged polythene strip up to the electroscope and roll it over the electroscope cap. The negatively charged polythene rod repels the negative charge which spreads on the plate and the leaf, making them repel each other hence leaf divergence. If the process is repeated several times the leaf divergence will keep increasing until it reaches the maximum point. **This way the electroscope is said to have been charged by contact.**
- ❖ The metal cap, leaf and rod will therefore remain diverged.
- ❖ **In damp weather**, this process may be difficult. It is helped if a razor blade is cello taped on to the cap so that it projects over the edge. The razor edge will then be found to gather the charge more readily than the cap alone.
- ❖ To charge an electroscope positively, a charge cellulose acetate strip is rubbed along the edge of the cap. Electrons are accepted from the cap to the strip which means that the cap and leaf gain a net positive charge.
- ❖ The leaf therefore diverges again.

Exercise

When a charged rod is held close to a metal sphere placed on an insulated stand, the charge distribution on the sphere is as shown below.

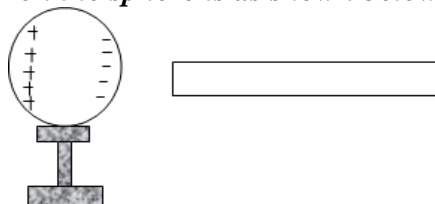

- What is the sign of charge on the rod?
- Describe a simple method to charge the rod.
- Explain why the far side of the metal sphere has a positive charge.
- What happens to the charges on the metal sphere, if the charged rod is moved away from the sphere?

The Gold Leaf Electroscope

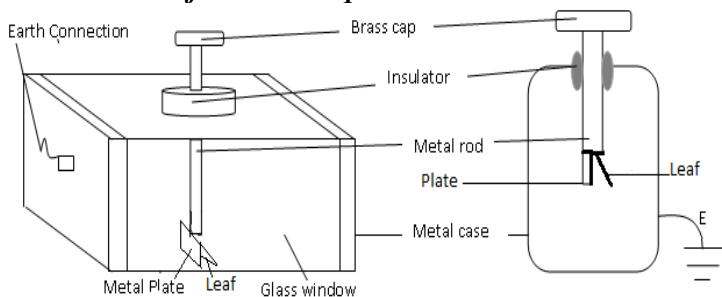

Charging a Gold Leaf Electroscope Positively by Induction

- ❖ Touch the cap of the electroscope with your finger to ensure that it is fully discharged.
- ❖ Bring a charged rod (-) close to the cap of the uncharged electroscope.
- ❖ While the rod remains in its position, touch the cap.
- ❖ Withdraw the finger and subsequently remove the rod.

Observations

- When the charged rod (-) is brought close to the cap, the leaf rises.
- When the cap is touched while the rod is in position, the leaf divergence decreases.

- When the finger is withdrawn and the then the rod, the leaf diverges.

Explanation

When the rod is brought close to the cap, electrons are repelled to the plate and the leaf making the leaf to diverge.

When the cap is touched, electrons flow to the earth through the body.

When the earth connection is broken by removing the finger and the rod, the positive charges redistributes onto the leaf and the plate. The leaf as a result diverges and the electroscope becomes positively charged.

Uses of Electroscope

1. Detecting the presence of charge on a body

❖ Charged bodies brought near the cap will cause the leaf to rise (diverge). If the leaf doesn't diverge the body is uncharged.

2. Measuring the insulating properties of an object(material)

❖ Charge the electroscope and bring the object to the top of the electroscope and earth the electroscope. The rate at which the leaf fall is the measure of the conducting ability of the object.

3. To measure the quantity of charge on a charged body

❖ If a body being tested has little charge on it the leaf of the electroscope will diverge a little and if the body has much charge on it the leaf will diverge more.

4. testing the sign of charge on a charged body

❖ If a charged body is brought near the cap of a charged electroscope, the leaf of the electroscope will diverge more if the body and the electroscope have similar charges and the leaf divergence will decrease if the two have different charges.

Testing for charges

a) Charge an electroscope negatively. Bring a negatively charged polythene strip close to the cap. Notice that the leaf diverges further.

b) Bring up a positive charge cellulose acetate strip close to the same negatively charged electroscope. Notice that this time the leaf collapses (decrease in divergence.)

c) Place your hand on any uncharged metal close to the charged electroscope. Notice again that the leaf collapses.

✓ **Note** that the results in experiments (b) and (c) were the same hence the collapsing of the leaf is not evidence for the presence of a charged body. We can therefore state the rule for testing a charge as follows :

1) *If the leaf of charge electroscope diverges further when a body brought close to the cap then that body is charged.*

2) *The sign of the charge on the body is the same as that on the electroscope.*

❖ Increase in divergence is the only sure way of testing the sign of charge on a body. Note that **charging by contact is not a sure way but induction is.**

Charge on electroscope	Charge brought near the cap	Effect on leaf divergence
+	+	Increase
-	-	Increase
+	-	Decrease
-	+	Decrease
+or-	Uncharged body	Decrease

Charges in Air

Air can be charged by:

✓ Heating

✓ Radiations

Applications of Electrostatic Charges

• Electrostatics precipitators

• Finger printing

• Spray painting

• photocopying

Danger of Electrostatics

❖ Rubbing liquid molecules can be charged. If the liquid is inflammable, it can spark and explode. It is advisable to store fuels in metal cans so that any charges generated continually leak out. This is the reason behind the presence of loose chain in tankers carrying inflammable liquids.

Assignment

1. *A nylon dress sticks on the body and crackles when removed. Explain.*

2. *You are given a positively charged electroscope and a charged body. Explain how you will determine the type of the charge on the charged body.*

3. *You are provided with the following: polythene rod, duster and a uncharged electroscope. Explain how you will charge the electroscope negatively.*

Chapter Nine

CELLS AND SIMPLE CIRCUITS

Introduction

- ❖ Electrical energy is used for lighting, Heating and operating electronic devices such as T.V, computers, high speed trains etc. This energy is carried through conductors like wires.

Electric Current

- ❖ Electric current is the rate of flow of charge (flow of charge per unit time). SI unit is the ampere (A)
- ❖ From the definition above,

$$\text{Current, } I = \frac{\text{Charge, } Q}{\text{Time, } t}$$

$$I = \frac{Q}{t}, \quad Q = It$$

Example

Calculate the amount of current flowing through a bulb if 360 coulombs of charge flows through it in 3.5 minutes.

Solution

$$I = \frac{Q}{t}$$

$$I = \frac{360}{3.5 \times 60}$$

$$= 1.714 \text{ A}$$

Types of Electric Current

- Direct current (d.c) – which flows in one direction only
- Alternating current (a.c) – which reverses direction with a given frequency

Simple Electric Circuits

- ❖ A simple electric circuit consist of a cell, a bulb and

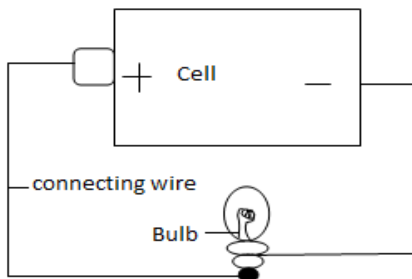

Notes



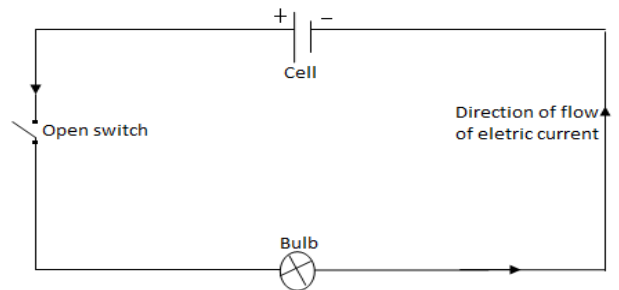



- A circuit that allows charges to move in a complete path when the switch is closed is said to be a closed circuit.
- A circuit that does not allow charges to move in a complete path such a circuit is said to be an open (broken circuit). Open circuit can also be as a result of loose connection of wires.
- For clarity and neatness, symbols are used in representing an electrical circuit.

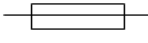

Direction of the Flow of Electric Current

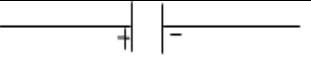
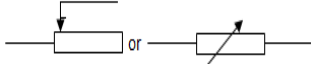
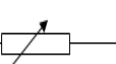
- ❖ Conventionally, the flow of current is from the positive terminal to the negative terminal of the cell. It is opposite to the direction of flow of electrons.
- ❖ The instrument for measuring electric current is called an ammeter while electric current flow is controlled by a variable resistor.

Device	Symbol
Cell	
Battery	
Switch	
Bulb/filament lamp	
Wires crossing with no connection	
Wires crossing with connection	
Fixed resistor	
Potential divider	

The table below shows some of the electrical symbols used in drawing circuits. Fuse	 or 
Capacitor	
Rheostat	 or 
Ammeter	
Voltmeter	
Galvanometer	 or 

Electromotive Force (E.m.f) and Potential Difference

- ❖ **Electromotive force (E.m.f)** refers to voltage across the terminals of a battery in an open circuit (when no current flows in the circuit).
- ❖ **Potential difference (Pd)** refers to the voltage across the terminals of a battery in a closed circuit (when current is flowing in the circuit).
- ❖ Potential difference and E.m.f are measured in **volts** by an instrument called **voltmeter**. A voltmeter is always connected in parallel (across).
- ❖ The difference between Potential difference and E.m.f is known as **lost voltage** $e.m.f = P.d + \text{lost voltage}$

$$\text{lost voltage} = e.m.f - P.d$$

- ❖ This voltage is lost because of the opposition to the flow of charges within the cell (**internal resistance**)

Connecting Cells in Series and Parallel

Cells in Series

- ❖ Two or more cells are connected such that the positive terminal of one is joined to the negative terminal of another one.
- ❖ Two or more cells connected in series make **a battery**



Note: Connecting cells in series increases the e.m.f and current in the circuit is higher.

Cells in Parallel

- ❖ Two or more cells are placed side by side, the positive terminals joined together and the negative terminals also connected together.
- ❖ When cells are in parallel arrangement their e.m.f. is the same as the e.m.f. of one cell.
- ❖ Current is supplied for a longer time in parallel connection of cells.

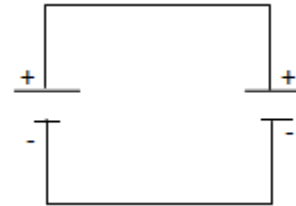

Note: Cells should be arranged in parallel only when they have the same e.m.f otherwise one will drain the other.

Bulbs in Series and Parallel Connection

Bulbs in Parallel

- ❖ Each bulb functions independently. If one goes off, others continue lighting.
- ❖ There's **decreased resistance** as the current has many alternative loops (complete paths) through which to flow.
- ❖ Bulbs in parallel have the same potential difference but different amounts of current.

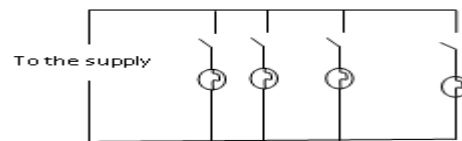

Bulbs in Series

- ❖ If one bulb goes off, others also go off.
- ❖ There's **increased resistance** thus the bulbs might not be as bright as those in parallel connection.
- ❖ Bulbs in series have the same current but different potential difference.

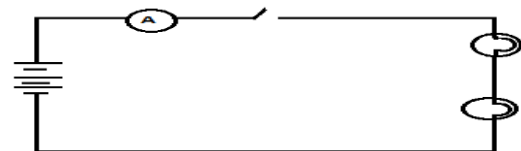

Note: Bulbs in parallel arrangement light brighter than those in series arrangement.

Example

Note:

An electrician installed electric wiring in a house and connected the bulbs and the switches as shown in the below.C

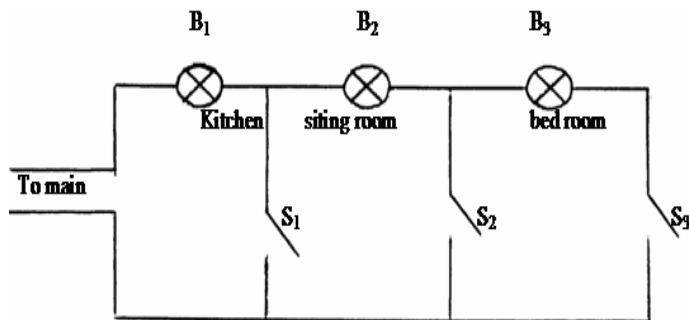

(a) Explain what happens when switch:

(i) S_1 is closed.

Only bulb B_1 will light;

(ii) S_2 is closed.

Bulb B_1 and B_2 lights but with less brightness because of increase in resistance.

(iii) S_3 is closed.

Bulb B_1, B_2 and B_3 will all light but with much less brightness compared to a (ii)

(b) (i) Using a redrawn diagram show the best position the bulbs should be installed.

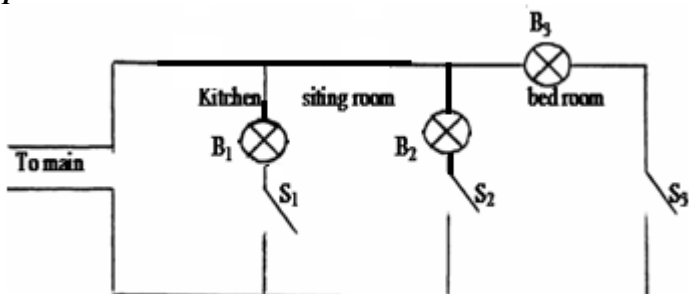

(ii) Explain why you consider the arrangement in (b) (i) above to be the best.

When the bulbs are connected such that they are in parallel, the circuit resistance is significantly reduced; and hence more current flow, the bulb lights with equal brightness since the operation voltage is the same;

Conductors and Insulators

❖ **Conductors** are materials that allow electric current to flow through them e.g. copper, silver, graphite and aluminium.

❖ **Insulators** are materials that do not allow flow of electric current through them e.g. plastic, paper and rubber.

1) Materials whose electrical properties fall between those of conductors and insulators are referred to as semi-conductors e.g. silicon and germanium.

2) Some liquids such as dilute sulphuric acid, sodium chloride solution and potassium hydroxide conduct electricity. They are referred to as electrolytes.

Sources of Electricity

❖ **Main sources:**

- Chemical cells
- Generators
- Solar cells

❖ **Other sources include:**

- Thermocouples
- Piezo electricity

Chemical Cells

These are cells that produce an E.m.f as a result of a chemical reactions. They are categorized into two:

Primary cells

❖ These are cells which cannot be recharged for use again e.g. simple cell.

Simple Cell

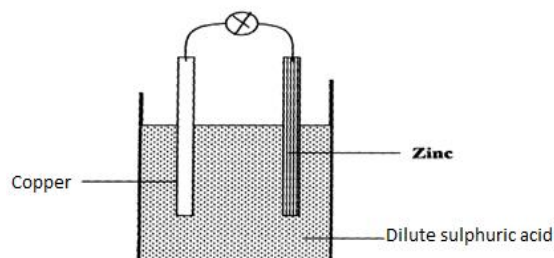

Defects of a simple cell

• **Polarization** – accumulation of bubbles around the copper plate (positive plate). This defect provides insulation to the flow of current and also sets up some “local” cells with copper whose electron flow tends to oppose the flow of electrons from the zinc plate. The overall effect is increase in the internal resistance of the cell, which reduces the flow of current.

• **Local action** – the zinc plate is depleted (eaten away) as it reacts with dilute sulphuric acid. Impurities in zinc promote local action.

Ways of correcting Polarization defect:

- Addition of potassium dichromate (depolarizer). Oxygen from the depolarizer combines with the hydrogen atoms to produce water.
- Removing copper plate and brushing off the gas bubbles.

Ways of correcting Local action defect:

- Use of pure zinc.
- Coating zinc with mercury (amalgamation).

The Leclanche' cell

Local action and Polarization have been minimized in this cell.

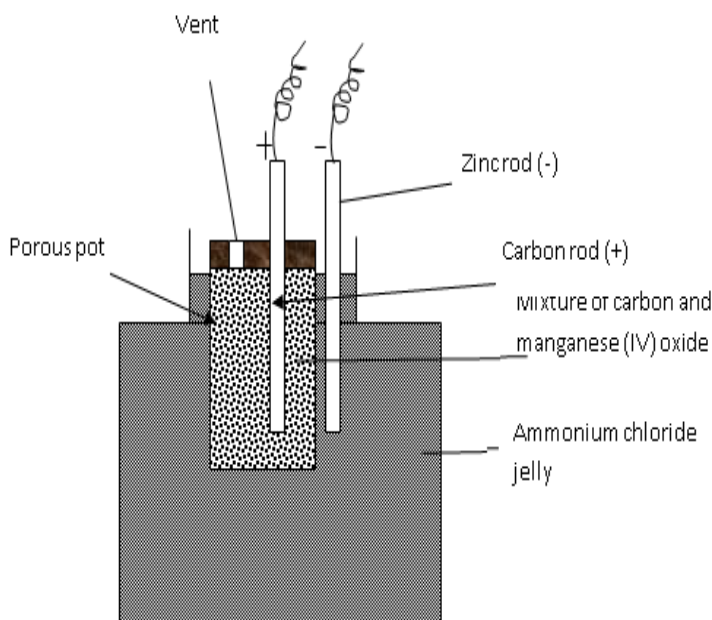

- The carbon rod (positive terminal) is surrounded with manganese (IV) oxide mixed with carbon powder.
- Carbon powder increases the effective area of the plates hence reduced resistance.
- The manganese (IV) oxide acts as a depolarizer (depolarization is slow thus large currents cannot be drawn out of this cell steadily for a long time).
- Local action is still a defect in this cell.
- The cell is used for purposes where current is not drawn from it for a very long time, like operating bells and telephone boxes. It has a longer life span than the simple cell.

The Dry Cell

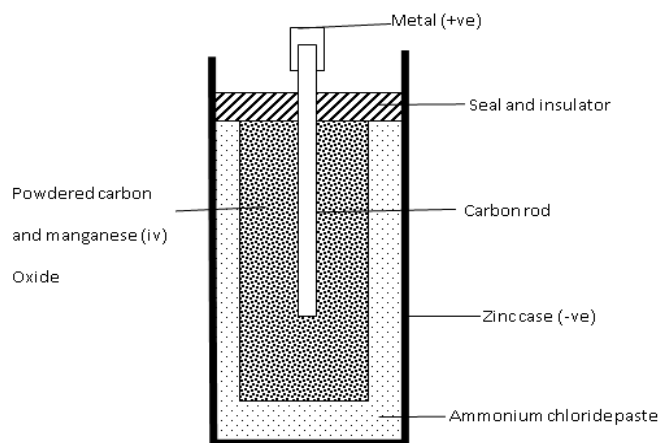

- It is referred to as dry cell because it has no liquid.
- The ammonium chloride solution in the Leclanche' cell is replaced with the ammonium chloride jelly or paste which is used as the electrolyte.
- Manganese (IV) oxide and act as the depolarizer.
- carbon powder increases the surface area of the positive electrode (carbon Rod)
- The zinc case acting as the negative electrode gets depleted by the ammonium chloride and changes to zinc chloride. Local action is still a defect in this cell.
- The cell cannot be renewed once the chemical action stops. A new dry cell has an e.m.f of about 1.5 V.

Care for the dry cell

- Large currents should not be drawn from the dry cell within a short time.
- The terminals should not be shorted.
- The cells must be stored in dry places.

Uses of the dry cells

- Dry cells are used in torches, calculators and radios.

Secondary Cells:

- These are rechargeable cells.
- They are also called storage cells as they can store electrical energy as chemical energy.
- Examples are the Lead-acid accumulator and the Nickel-alkaline accumulator.

Lead – acid accumulator

- Consist of positive and negative plates which are made of lead-antimony alloy.
- The plates are dipped in sulphuric acid solution which is an electrolyte.
- The caps have small vent holes which allow gases to escape(O_2 and H_2)
- If the density of the acid becomes too low the accumulator is said to be discharged.
- It is charged by connecting a d.c source as shown below.

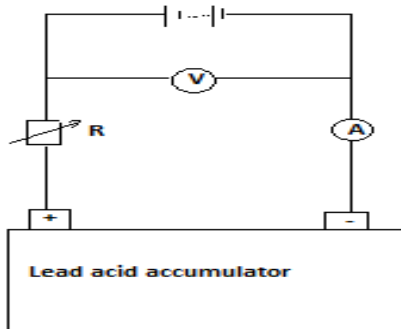

- This is the most reliable, long lasting and cost-effective of the secondary cells. A 12 V lead-acid accumulator has six cells connected in series.

Capacity of an Accumulator

- This is the amount of current that can be drawn in a given time from the battery.
- It is expressed in ampere-hours (Ah).

Examples

1. A battery is rated 120 AH. How long will it work if it steadily supplies a current of 4A?

$$\begin{aligned} \text{capacity} &= \text{current in amperes} \times \text{time in hours} \\ 120 \text{ AH} &= 4 \text{ A} \times \text{time} \\ \text{time} &= \frac{120 \text{ AH}}{4 \text{ A}} = 30 \text{ hours} \end{aligned}$$

2. The current capacity of an accumulator is 40Ah. Find the amount of current flowing if the accumulator is used for 600 minutes.

$$\text{capacity} = \text{current in amperes} \times \text{time in hours}$$

$$\begin{aligned} 40 \text{ AH} &= I \times \frac{600}{60} \\ I &= \frac{40 \text{ AH}}{10 \text{ H}} = 4 \text{ A} \end{aligned}$$

Maintenance of the Accumulators

- 1) The level of the electrolyte should be checked regularly and maintained above the plates. Topping should be done by distilled water; NOT ACID!
- 2) The accumulator should be charged when the e.m.f of the cell drops below 1.8 V and when the relative density of the acid is falls below 1.12 (using a hydrometer).
- 3) Large currents should not be drawn from the battery for a long time.
- 4) Should not be left in a discharged condition for a long period as **sulphation** may take place. (the lead (II) sulphate deposits on the plates harden up and cannot be converted back to lead (II) oxide and lead.)
- 5) Shorting/ overcharging of the accumulator should be avoided.
- 6) The terminals should always be kept clean and greased.
- 7) The accumulator should not be directly placed on the ground during storage. It should be rested on some insulator like a wooden block.

Alkaline Accumulators:

- ❖ The electrolyte in this case is an alkaline solution, such as potassium hydroxide.
- ❖ The common types are nickel-cadmium and nickel-iron accumulators.

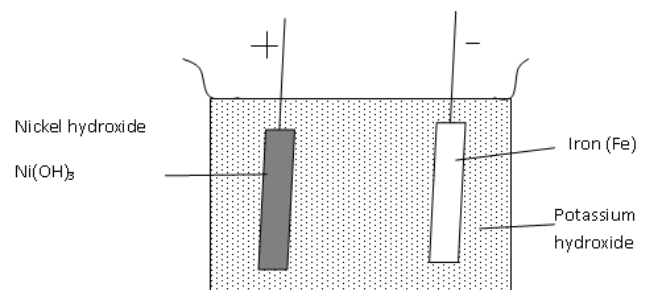

Advantages of Alkaline Accumulators over Lead – Acid Accumulators

1. Large currents can be drawn from them over a short period of time.
2. They require very little attention to maintain.
3. They are lighter (more portable) than the Lead – acid accumulators.
4. They can be kept in a discharged condition for a very long time before the cells are ruined.

Disadvantages

1. They are very expensive.
2. They have a lower e.m.f per cell.

Uses of Accumulators

They are used in ships, hospitals and buildings where large currents might be needed for emergency.

Differences between primary and secondary cells

Primary cells	Secondary cells
Cannot be recharged after use	Are rechargeable
Small current can be drawn from them	Large current can be drawn from them

Revision Exercise

9. In terms of electrons, distinguish between good conductors, poor conductors of electricity and insulators.
10. (a) Define current and state its SI unit.
(b)(i) A charge of 180 coulombs flow through a lamp every minute. Calculate the current flowing through the lamp.
(ii) Calculate the number of electrons involved (charge of electron is $1.6 \times 10^{-19} \text{ C}$)
11. A battery circulates charge round a circuit for 1.5 minutes. If the current is held at 2.5A, what quantity of charge passes the wire?
12. Define electromotive force and distinguish it from potential difference of a cell.
13. (a) Draw a circuit diagram of three-cell torch.
(b) What do you understand by?
(i) Open circuit?
(ii) Closed circuit?
14. Explain why lights in a house are wired in parallel and not in series.
15. (a) Give three differences between primary and secondary cells.
(b) In making a simple cell, the two electrodes used are not of the same kind. Explain.

1. You are provided with a car battery, a switch and two headlights of a car. Draw a possible circuit diagram for the arrangement that will allow the driver to switch on the two lights simultaneously.

2.(a) Draw a well-labelled diagram of a dry cell and explain how it works.

(b) What are the defects and the remedies in the working of a dry cell?

(c) How are dry cells maintained?

3. Eight dry cells can be arranged to produce a total e.m.f of 12V, just like a car battery.

- a. What is e.m.f of an individual cell?
- b. Why is it possible to start the car with the lead-acid accumulator, but not with eight dry cells in series?

4.(a) Draw two separate diagrams showing a lead-acid accumulator when it is:

- a) Charging
- b) Discharging.

(b) Describe the changes that can be observed during the two processes above.

(c) Why is it dangerous to light a cigarette near a charging car battery?

5.(a) What do you understand by the term capacity of a lead-acid accumulator?

(b) Why is it effective to charge a car battery over a long time with a very small current rather than a big current within a short time?

(c) A car battery is rated 40Ah and it is expected to supply a constant current for 120 minutes. What is the strength of current delivered?

6. State at least five precautions that you would take to maintain accumulators in your laboratory.

7. State the advantage and disadvantage of lead-acid accumulators over the alkaline accumulators.

8. The figure below shows the set up for a simple cell.

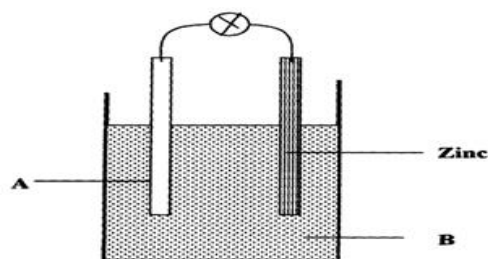

- a) Name the Electrode A and the solution B
- b) State two reasons why the bulb goes off after a short time
16. State one advantage of a lead-acid accumulator over a dry cell
17. State one defect of a simple cell and explain how it can be corrected.
18. The diagram below shows a simple cell:-

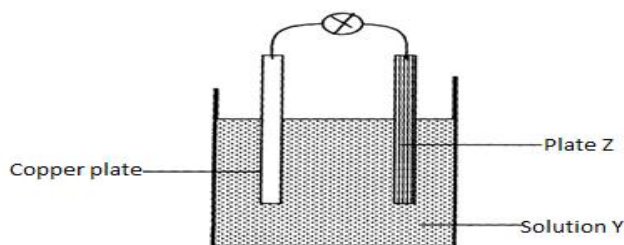

- a. Name z and solution y
- b. Name and explain the defect that occurs at plate z
- c. Give one method of preventing the defect that occurs at the copper plate
19. Explain why eight 1.5V cells arranged in series to give a total of 12V cannot be used to start a car. But car battery of 12V starts a car
20. Define the term topping as used in simple cells and circuits.
21. I) A girl opened up a used up dry cell and found the following:
- a. The zinc casing was depleted
- b. The cell was watery
- II) Name the cell defect
- III) Three identical bulbs are connected in series with a battery of dry cells. At first the bulbs shine brightly but gradually become dimmer. Using the same cells, explain how you would increase the brilliance of the bulbs
22. A car battery requires topping up with distilled water occasionally. Explain why this is necessary and why distilled water is used
23. State one advantage of:
- a. A lead-acid accumulative over a dry cell
- b. A dry cell over lead-acid accumulator

**This is a Property of Mwalimu
Consultancy Ltd. Contact Mr
Isaboke
0746-222-000 for more
Educational Materials.**

Chapter Ten

RECTILINEAR PROPAGATION OF LIGHT AND REFLECTION AT PLANE SURFACES

Introduction

- ❖ Optics is a branch of physics which studies the behaviour of light as it traverses various media.
- ❖ Optical instruments such as cameras, microscopes, periscopes and laws governing their working form a major part of this branch of physics.
- ❖ Light is a form of energy. Light regulates your daily life. You need light to see the size, shape and colour of things around you.

Sources of Light

- ❖ There are two : **luminous (incandescent)** and **non-luminous**
- ❖ **Luminous objects** are those which produce their own light e.g. sun, candles, electric lamps, glowing worms etc.
- ❖ **Non-luminous** objects are those which don't give their own light but reflect light that comes from a luminous object. These are objects. Examples are: the moon, paper, you *etc.*
- ❖ You can see an object clearly if light from it enters your eyes.

Transparent, Translucent and Opaque Objects

- ❖ **Transparent objects** are those which allow light to pass through them e.g. a glass window, clear water, the air around you. All these substances let light pass through them.
- ❖ **Opaque objects** are those which cannot allow light to pass through them e.g. wool, steel, Brick.
- ❖ **Translucent bodies** are those which let light pass through them, but scatter in all directions e.g. lamp shades, frosted glass, some plastic etc.

Rectilinear Propagation of Light

- ❖ This is the property of light to travel in a straight line in a medium of homogeneous propagation density.
- ❖ Light does not travel around corners. The formation of shadows shows that light travels in a straight line. When an opaque body is placed in a beam of light, a shadow is formed.

Demonstrating Rectilinear Propagation of Light

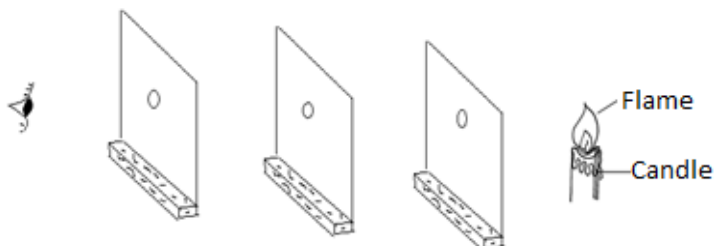

- ❖ Make a small hole in each of the three card boards ensuring that all the holes are at the same height.
- ❖ The lamps positioned in such a way that a ray of light passes through all the holes.
- ❖ When the cardboard is displaced by moving it slightly to the one side, the eye will not see the lamp. This shows that light travels in a straight line.

Rays of Light and Beam of Light

- ❖ **A ray** is a narrow stream of light of negligible thickness while a **beam of light** is a collection of rays of light.

Types of beams

- ❖ A beam in which rays are parallel to each other is called **parallel beam**.

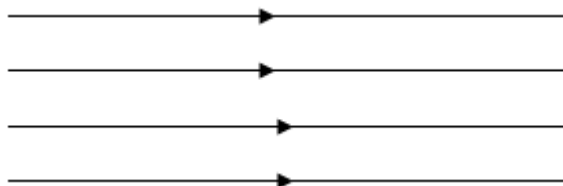

- ❖ A beam in which the rays converge at a point is called a **convergent beam**.

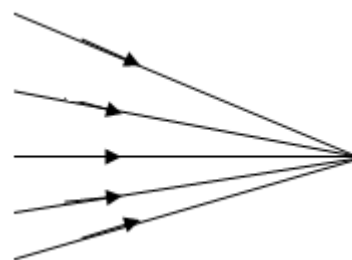

- A beam in which the rays spreads out from a point is a **divergent beam**

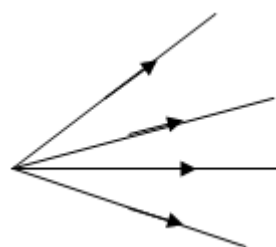

The Pinhole Camera



- ❖ A pin-hole camera is made using a small rectangular box with a pin hole at one end, a large rectangular hole at one end, a large rectangular hole at the other end.
- ❖ The rectangular hole at the back is covered with a screen of special paper like grease proof paper which lets some light pass through it (i.e. it is translucent).

Advantage

- ❖ It is able to form focused images on the film of objects both near and far from the camera.

Image Formation by a Pinhole Camera

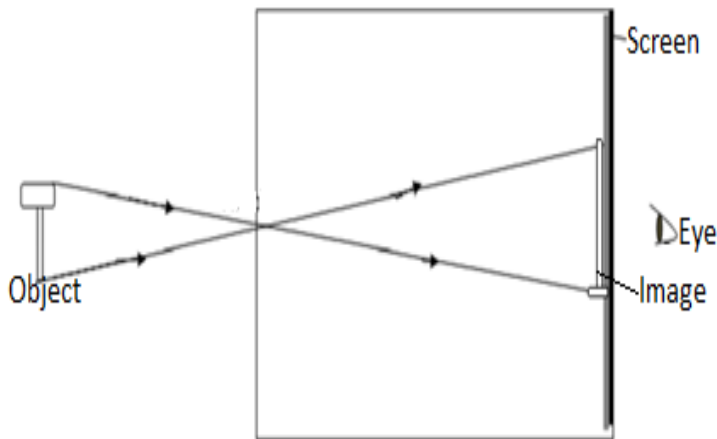

The Length (Size) Of Image

- ❖ The length of the image formed depends on:
 - a) The distance of the object from the pinhole
 - b) The length of the camera box

MAGNIFICATION

- ❖ This is the ratio of the image size to the object size or the ratio of the image distance to the object distance.

$$\text{Magnification} = \frac{\text{Image size}}{\text{object size}}$$

$$\text{Magnification} = \frac{\text{image distance}}{\text{object distance}}$$

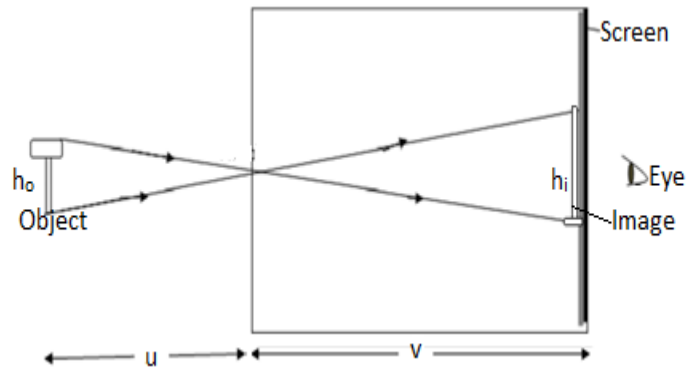

h_o =object height
 h_i =image height
 u =object distance

v =image distance from pinhole

Given that magnification is m , then

$$m = \frac{h_i}{h_o} \text{ or } m = \frac{v}{u} \text{ and so } \frac{h_i}{h_o} = \frac{v}{u}$$

Examples

1. A pinhole camera of length 15 cm forms an image 3cm high of a man standing 9m in front of the camera what is the height of the man?

$$\begin{aligned} \frac{h_i}{h_o} &= \frac{v}{u} \\ \frac{0.03 \text{ m}}{h_o} &= \frac{0.15 \text{ m}}{9 \text{ m}} \\ h_o &= \frac{0.03 \text{ m} \times 9 \text{ m}}{0.15 \text{ m}} = 1.8 \text{ m} \end{aligned}$$

2. Lamp A of height 6cm stands in front of a pinhole camera at a distance of 24 cm. The camera screen is 8cm from the pinhole. What is the height of the image?

$$\begin{aligned} \frac{h_i}{h_o} &= \frac{v}{u} \\ \frac{h_i}{0.06 \text{ m}} &= \frac{0.08 \text{ m}}{0.24 \text{ m}} \\ h_i &= \frac{0.08 \text{ m}}{0.24 \text{ m}} \times 0.06 \text{ m} \\ h_i &= 2 \text{ m} \end{aligned}$$

Exercise

1. An image 100mm long of a man 2m tall is pinned on top of a pin-hole camera. The distance of pin hole from the screen if the man is standing 6cm from the pinhole.
2. An object 1m tall forms an image 5 cm tall from the screen of a pinhole camera. Find the distance of the object from the pin hole of the object if the length of the camera box is 40 cm.

Effect on the Image Formed by the Pinhole Camera On:

(a) Many pin holes

❖ Each pinhole will form its image resulting into brighter but blurred image.

(b) Large pinhole

❖ A large hole is equivalent to several holes and will produce brighter but blurred image.

❖ However, a sharp image can be produced where a wide hole or several holes have been used by simply placing a converging lens in front of the many holes and in contact with the box. The convex lens brings all rays from a point on object to unique point on the screen.

The pin-hole camera can be modified as follows in order to take photographs:

- ❖ Should be painted black on the inside to eliminate reflection of light.
- ❖ Translucent screen to be replaced by light-tight lid with photographic film fitted on the inside.
- ❖ Should be covered with a thin black card which acts as a shutter.

The exposure time of a pin-hole camera depends on:

- Size of the pin-hole
- Lighting conditions
- Sensitivity of the film
- Length of the camera

Advantage of the Pinhole Camera over the Lens Camera

❖ The pinhole camera is preferred to the lens camera because it does not produce distortion.

The disadvantages of using a pin hole camera:

- a) It takes a long time for image to be formed since the amount of light passing through the hole is small.
- b) It cannot be used to take photographs of moving objects.

Shadows

❖ A shadow is a shade cast by an object blocking direct rays of light. The formation of shadows depends on the fact that light travels in a straight line

The size of the shadow formed depends on:

- a) Size of sources of light.
- b) Size of opaque object.
- c) Distance between the object and source of light.

Shadow Formed by a Point Source

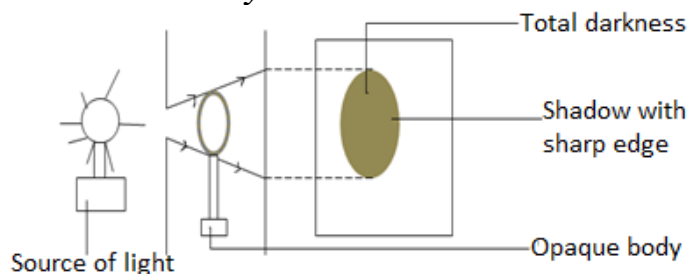

❖ A point source of light is one which is small enough for all the rays of light to come effectively from a single point.

❖ The shadow is uniformly and totally dark all over and is called **umbra**. The umbrella shape edges on the shadow shows that light travels on a straight line.

Shadows Formed by an Extended Source of Light.

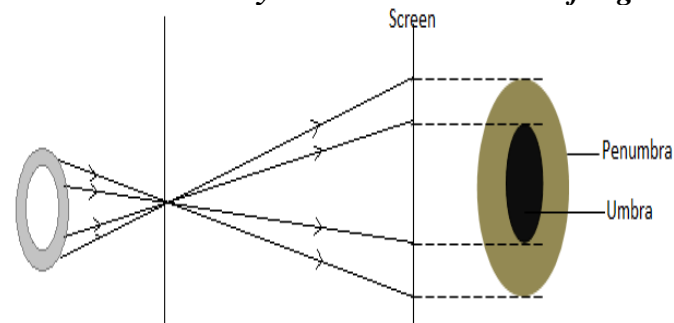

❖ An extended source of light is large enough for rays to be seen to come from many points.

❖ The shadow is larger and has a central dark region called **umbra** surrounded a ring of partial shadow called **penumbra**.

Application of extended light sources

- a) Lampshades are used at home to provide a more pleasant kind of lightning.
- b) Fluorescent tubes are usually surrounded by a frosted diffuse to scatter the light & reduce shadow sharpness.

Eclipses

An eclipse is the total or partial disappearance of sun rays as seen from the earth.

The Solar Eclipse or Eclipse of the Sun

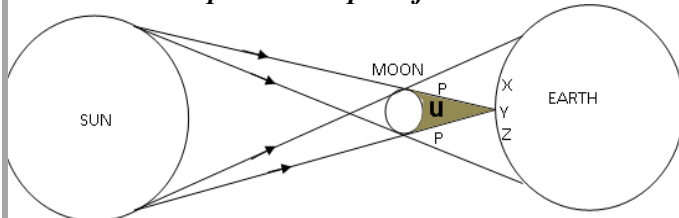

- ❖ The solar eclipse occurs when the moon comes between the sun and the earth

The Annular Eclipse of the Sun

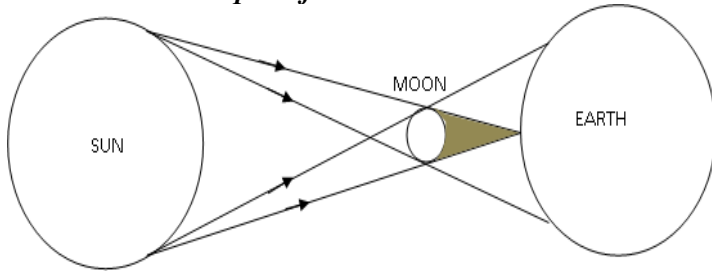

- ❖ It occurs when the distance of separation between the earth and the moon is great. The umbra of the moon does not totally cover the sun edge of the dark disk of the moon.

Lunar Eclipse or Eclipse of the Moon

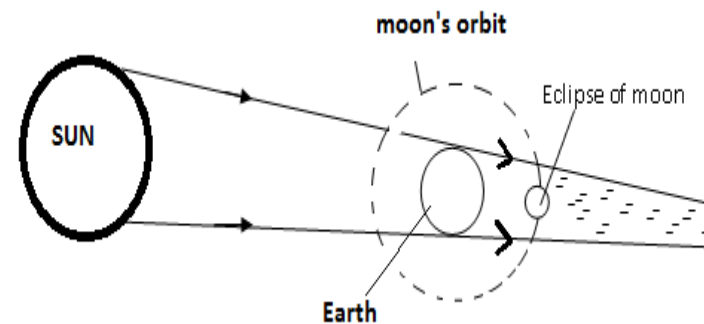

- ❖ The eclipse of the moon occurs when the earth comes between the sun and the moon.
- ❖ When the lunar eclipse occurs, it lasts longer (about 1hr) than the solar eclipse because the moon is much smaller than the earth.
- ❖ During a total lunar eclipse some light reaches the moon due to refraction by the earth's atmosphere & make it look a coppery colour.

REFLECTION BY PLANE MIRRORS.

- ❖ When a ray of light meets a plane mirror it is reflection.
- ❖ An ordinary mirror is made by depositing a thin layer of metal, often silver paint at the back of the glass which acts as the reflecting surface.

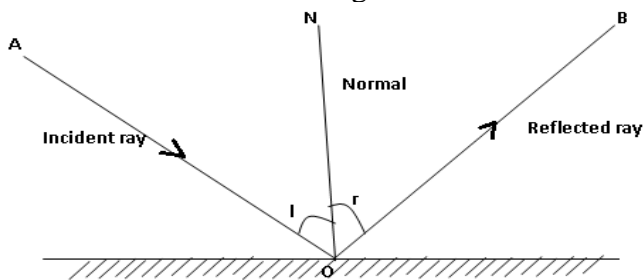

- ❖ The ray from the source AO is called the **incident ray**. The ray that bounces off from the Mirror O is called the **reflected ray**. ON is the **normal**.
- ❖ The angle between incident ray and the normal is called **Angle of incident angle, I** between the normal and the Reflected ray is called **angle of reflection**.

The Laws of Reflection

1. The angle of incidence is equal to the angle of reflection.
2. The incident ray, normal and reflected ray at the point of incidence all lie on the same plane.

Types of Reflection

a) Regular or Specular Reflection

It occurs when parallel incident rays are reflected parallel to each other when reflecting surface is smooth.

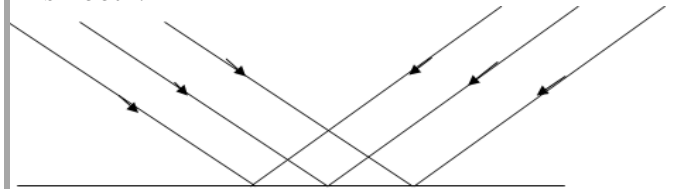

b) Irregular or Diffuse Reflection

Parallel incident rays are reflected in different directions for

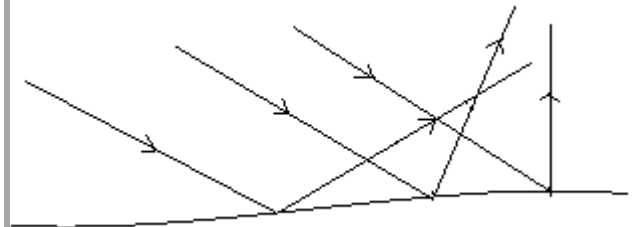
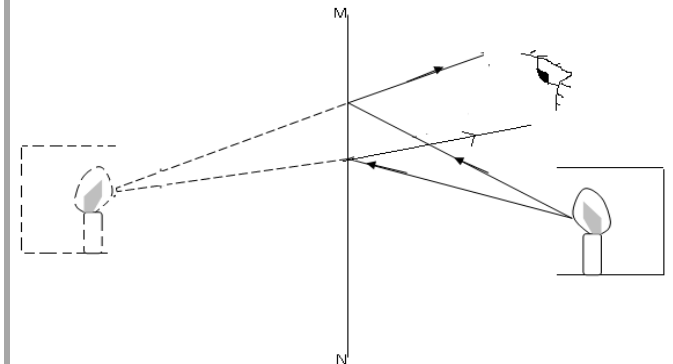
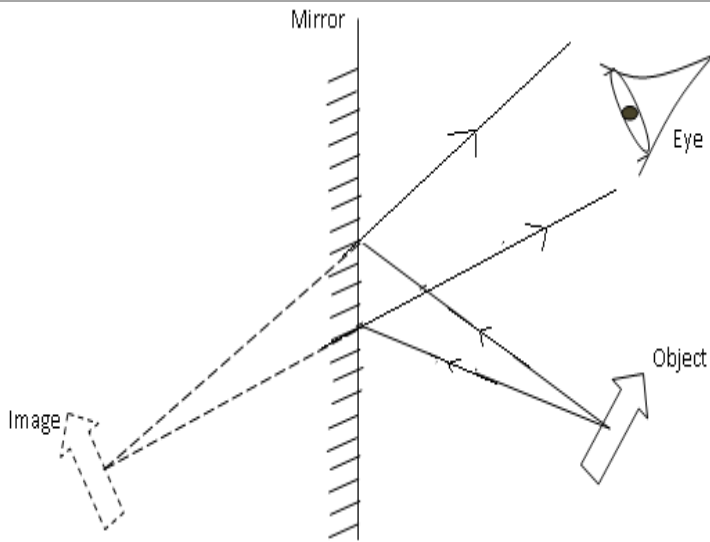

Image Formation by a Plane Mirror.

- ❖ The image of an object seen in a plane mirror is formed by rays of light travelling in straight lines which are reflected according to the laws of reflection.





From the above diagram one can see that **the image formed in a plane mirror is always:**

- Erect (Upright)
- As far behind the mirror as object is in front of it.
- Virtual.

A virtual image is one:

- which cannot be received on the screen
 - which is formed by the intersection of virtual rays.
- Laterally inverted i.e. left appears on the right & vice versa
 - The same size as the object.

Image Formation in Parallel in Mirrors

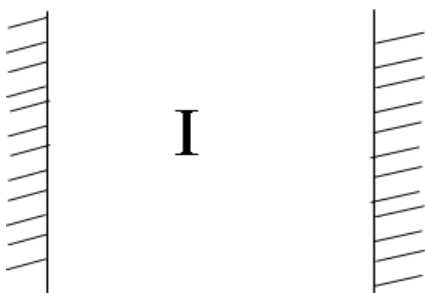

- When an object is placed between two parallel mirrors as shown above an **infinite number of images** are formed.
- Each image seen in one mirror acts as a virtual object which in turn forms an image in the other mirror.
- The image becomes fainter because light energy is absorbed by the mirror at each successive reflection.
- The number of images formed by two mirrors inclined at an angle is given by the formula.

$$n = \frac{360}{\theta} - 1$$

Exercise

- Find the number of images formed when mirrors are inclined at 20°
- Find the angle between two mirrors if 35 images are formed
- At what angle would two mirrors be inclined if the number of images formed are (i) 17 (ii) 29?

Rotation of a Mirror

- When a mirror is rotated through an angle θ the reflected ray turns through 2θ .
- Hence, the reflected ray always turns through twice the angle through which the mirror is rotated.

Exercise

- A mirror is rotated through an angle of 15° through what angle does the reflected ray turn?
- A mirror is rotated through a certain angle and the reflected ray turned through 40° what angle had the mirror been turned?
- An incident ray makes an angle of 25° with the normal. If the mirror is turned through 9° in the anticlockwise direction from the horizontal, through what angle is the reflected ray rotated?

Application of Plane Mirrors

(a) The Periscope

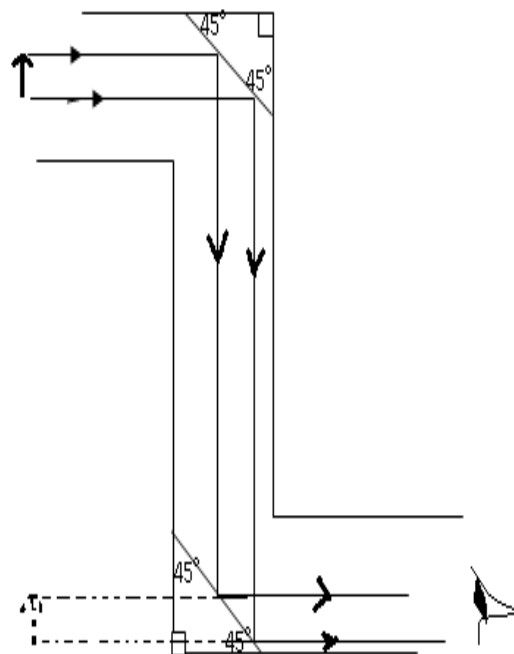

- A periscope consists of a plane mirrors parallel to one another and inclined at angle of 45° to the horizontal.
- They are used to help one see over an obstacle.

❖ Periscopes in submarines use prisms instead of plane mirrors because.

1. The silver part of the mirror easily gets damaged
2. Thick mirrors produce multiple refractions
3. There is no lateral inversion with prisms.

(b) Use of plane mirrors in instrument scales

- ❖ Plane mirrors are often used behind pointers as instruments to improve the reading accuracy.
- ❖ When the pointer is viewed at an angle its image will be seen through the plane mirror.
- ❖ The image seen will enable the reader to know that reading being taken will have an error due to parallax. The reader will therefore position the eye vertically so that the image of the pointer is not seen and hence a correct reading will be taken.
- ❖ The sports galvanometer uses a ray of light as a pointer instead.

(c) The kaleidoscope

- ❖ It applies the principle of mirrors inclined at an angle.
- ❖ It consists of two mirrors M_1 and M_2 placed to each other at 60° to each other inside a tube.
- ❖ The instrument is used by designers to obtain ideas on systematic patterns.

Revision Exercise

1. (a) Sally went to Mary salon to have her hair dressed. The salon had two parallel mirrors placed on the walls which are 3 meters apart. While waiting to be attended to, she sat at a distance of 1 meter from one of the walls and noticed that there were multiple of her in each mirror. Determine the distance between the two nearest images formed in the two mirrors.

(b) Two plane mirrors are placed at an angle of 60° as shown below. A ray of light makes an angle of 40° with mirror m_1 and goes to strike mirror M_2 . Find the angle of reflection of Mirror M_2

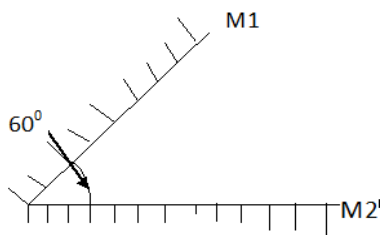

2. What is rectilinear propagation of light?
3. Draw a ray diagram to show how a pinhole camera forms an image.
4. State the changes that would occur in the size and brightness of the image formed if
 - a) The object distance is made large.

b) The length of the camera is made longer.

c) The single hole is replaced by four pinholes close together.

5. Define the term reflection of light.

6. State the Laws of reflection of light.

7. The mirror AB and CD are at right angles to each other.

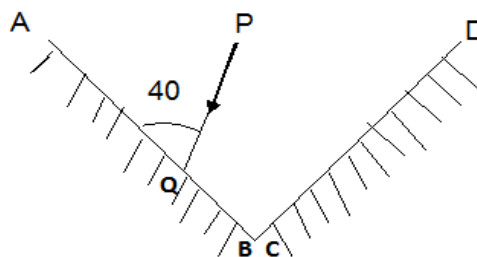

a) What is the value of the angle of incidence of the ray PQ on the mirror AB?

b) Complete the diagram to show the path taken by the ray PQ after reflection at both mirrors.

c) Determine:

- I. Angle of reflection on AB.
 - II. Angle incidence on CD.
 - II. Angle of reflection on CD.
8. If a girl walks away from a plane mirror at a speed of 2m per second,
- I. In what direction does her image move?
 - II. With what speed does her image move?
9. The figure below shows mirrors AB and CD inclined at right angles. A ray PO makes an angle of 30° with mirror AB as shown.

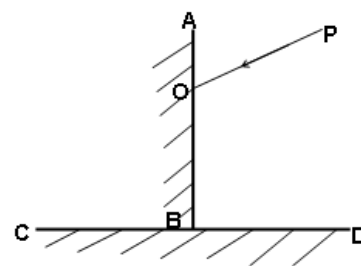

(i) Show the path of the ray after reflection from both mirrors.

(ii) What is the angle of incidence on the mirror CD?

THE END

F1 TOPICAL REVISION

QUESTIONS

***A SERIES OF TOPICAL REVISION
PHYSICS QUESTIONS IN THIS CLASS.***

***An Intensive Analysis of Past KCSE
Questions. Candidates are Hereby
Advised to Keep attention to this
Crucial Quick Revision Kit.***

For Marking Scheme/Answers

CALL/WHATSAPP 0746 222 000

MEASUREMENT I

1. (a) Distinguish between density and relative density of a substance
 (b) A ship of mass 1300 tonnes floats on sea water:
 - (i) What volume of sea water is displaced (Density of sea water is 1025kg/m^3)
 - (ii) Suppose it sails from sea water to fresh water, what cargo must be removed so that the same volume of water is displaced? (Density of fresh water = 1000kg/m^3)
 (c) Describe an experiment to verify the law of floatation
2. Define **relative density**
3. A bathroom shower has 200 holes each 2.5mm^2 in area. Water flows from a pipe of cross-section area of 15cm^2 at 5m/s to the shower. Determine the speed of the spray.
4. A piece of metal **N** of mass 2kg weighs 18N in water and 12N in liquid **M**. Determine the density of ;
 - (i) The metal **N**
 - (ii) The liquid **M**
5. A measuring cylinder contains 50cm^3 of light oil at 0°C . When a lump of dried ice is placed in the oil, the total volume is 72cm^3 . Determine the density of the ice

The **figure 1** below shows a manometer connected to a gas supply. The pressure of the gas supply above the atmospheric pressure is equivalent to a 20cm column of water. Use this information and the figure to answer questions 2 and 3.

FORCE

1. (a) The figure below shows a balloon carrying hydrogen gas 3m^3 of density 0.09kgm^{-3} . The mass of the balloon fabric is 2kg and the density of air is 1.25kgm^{-3}
 - i) Determine the tension in the string
 - ii) If the string is suddenly cut, calculate the acceleration of the balloon upwards
 - iii) What is the maximum mass of the equipment the balloon can lift at a constant velocity
- b) State and explain **two** features of a hydrometer that make it **sensitive** in its function
2. A block of mass 5kg rests on an inclined surface as shown in the diagram below:

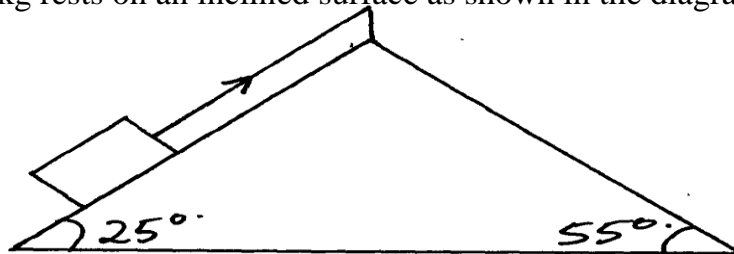

Determine the static friction on the block

3. State **two** factors that would raise the boiling point of a liquid
4. Give a reason why water wets glass while mercury does not.
5. (a) Give an example where force is applied and no work is done
 (b) The graph below shows the variation between force and distance for a boy pushing a concrete block of mass 25kg through a vertically height of 12m .



- (i) Determine the total work done by the boy within 70m
- (ii) How much energy is wasted?
- (iii) Give an account for the energy wasted
6. State the principle of moments.
7. State any **two** factors that affect the earth's gravitational force
8. Figure 3 below shows a wire loop with a string that has been dipped into soap solution.

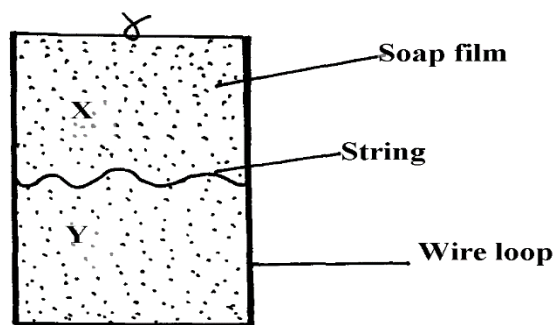
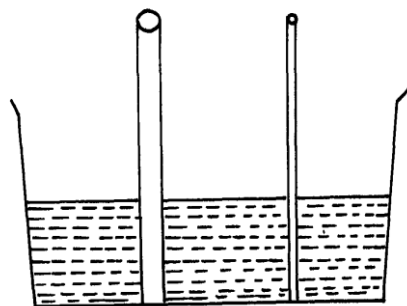

Fig. 3

- i) Sketch a similar diagram to show the observed effect if the soap film is punctured at X
- ii) Explain the observations made in (i) above
9. **Figure 2** shows two glass tubes of different size of bore, dipped in a glass beaker half full of water



Complete the diagram to show how water will rise up in the two glass tubes

10. (a) State the conditions necessary for the law of conservation of linear momentum to hold
 (b) The diagram *figure 13* below shows a steel ball bearing gently dipped in a viscous liquid contained in a tall cylinder

fig. 13

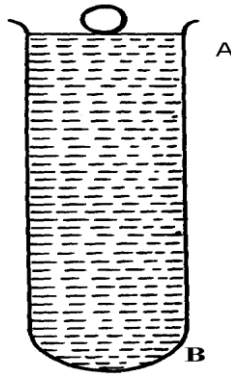

- (i) Name giving their directions the forces acting on the ball bearing as it moves down the cylinder
 (ii) The graph in *figure 14* below shows the velocity-time graph (a) for the motion of the above ball

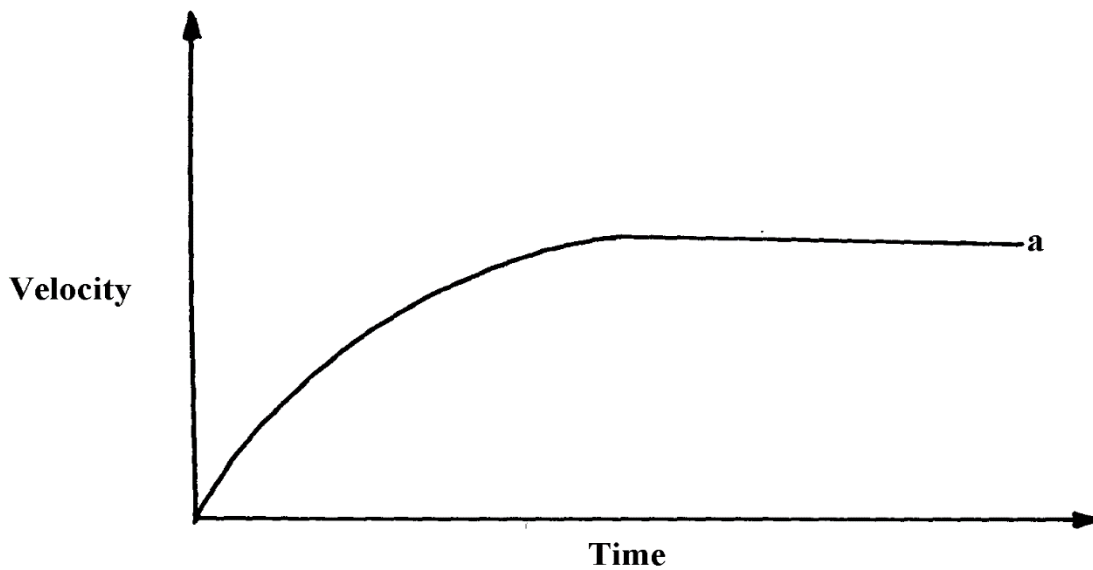
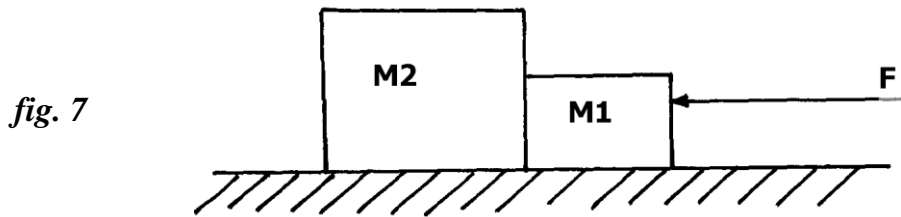

fig. 14.

On the same diagram, draw the graph (b) for a steel ball of smaller radius in the same liquid

- (iii) Explain the difference in the two graphs (a) and (b)
 (c) (i) A breakdown truck tows a car of mass 1000kg along a level road, and accelerates at 0.5m/s^2 . What is the tension in the tow line
 (ii) If the tow line in (c)(i) above breaks when the car reaches a speed of 36km/h, how far will the car travel before coming to rest if the breaking force is 2000N?
 11. Explain why it is easier to ride a bicycle round a bend on a road if the surface is dry than when it is wet
 12. Give **one** difference between limiting and dynamic forces of friction
 13. Mercury on a clean glass slide collects into small spherical balls as shown in figure 2 below. Explain why

14. The *figure 7* below shows two blocks of masses $M_1=1.5\text{kg}$ and $M_2 = 2.0\text{kg}$ which are in contact on a frictionless table



A force $F=7\text{N}$ acts on the bodies, determine the force on mass M_2

15. State **one** factor that determines the depth to which mercury is depressed in a glass capillary tube.

PRESSURE

1. State the possible reason why, if water is used as a barometer liquid, the glass tube required to hold the column of the liquid is longer
2. State the definition of atmospheric pressure
3. What is the density of alcohol?
4. A person's lung pressure as recorded by a mercury manometer is 90 mm Hg. Express this pressure in SI units.
5. The figure below shows two light pith balls arranged as shown.

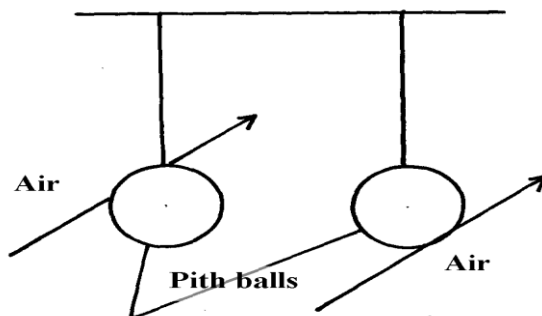

Pith balls

State what is observed when air is blown on the outer sides of the pith balls.

7. The barometric height at sea level is 76cm of mercury while at a point on a highland it is 74cm of mercury. What is the altitude of the point? (Take $g = 10\text{m/s}^2$, density of mercury = 13600kg/m^3 and density of air as 1.25kg/m^3)
8. a) Define specific latent heat of fusion of a substance
b) Water of mass 200g at temperature of 60°C is put in a well lagged copper calorimeter of mass 80g. A piece of ice at 0°C and mass 20g is placed in the calorimeter and the mixture stirred

gently until all the ice melts. The final temperature, T , of the mixture is then measured.

Determine:

- i) The heat absorbed by the melting ice at 0°C
- ii) The heat absorbed by the melted ice (water) to rise to temperature T (answer may be given in terms of T)
- iii) The heat lost by the warm water and the calorimeter (answer may be given in terms of T)
- iv) The final temperature of the mixture

(Specific latent heat of fusion of ice = $334\,000\text{ J kg}^{-1}$)

Specific heat capacity of water = $4\,200\text{ J kg}^{-1}\text{ K}^{-1}$

Specific heat capacity of copper = $900\text{ J kg}^{-1}\text{ K}^{-1}$)

9. Figure 4 below shows a measuring cylinder of height 30cm filled to a height of 20cm with water and the rest occupied by kerosene

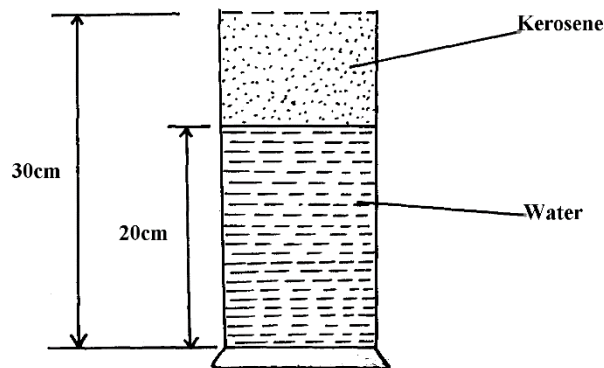

Fig. 4

Given that density of water = 1000 Kgm^{-3} , density of kerosene = 800 Kgm^{-3} and atmospheric pressure = 1.03×10^5 pascals, determine the pressure acting on the base of the container

10. State Pascal's principle of transmission of pressure

11. A helical spring extends by 1 cm when a force of 1.5N is applied to it. Find the elastic potential energy stored in it.

12. Two immiscible liquids are poured in a container to the levels shown in the diagram below.

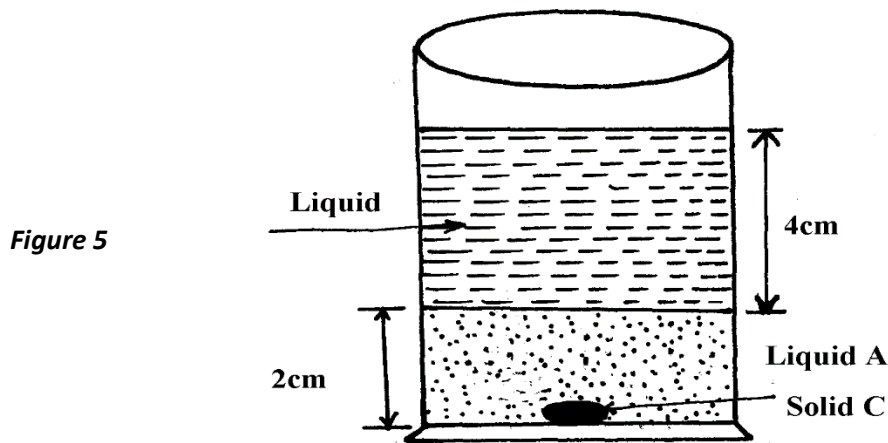
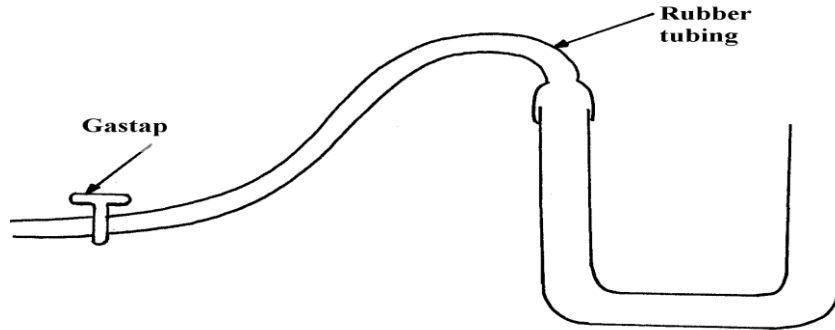

Figure 5

If the densities of the liquids **A** and **B** are 1g/cm^3 and 0.8g/cm^3 respectively, find the pressure acting upon solid **C** at the bottom of the container due to the liquids

13. Mark the position of the water levels in the manometer when the gas supply is fully turned on
14. Calculate the pressure of the gas supply (Atmospheric pressure = $1.0 \times 10^5 \text{Pa}$)

figure 1



15. A small nail may pierce an inflated car tyre and remain there without pressure reduction in the tyre. Explain the observation
16. (a) State **two** ways of increasing pressure in solids
(b) The figure 1 shows a liquid in a pail

fig. 1

Suggest a reason why pail manufacturers prefer the shape shown to other shapes

17. **Figure 8** shows a funnel inverted over a light ball.

fig. 8

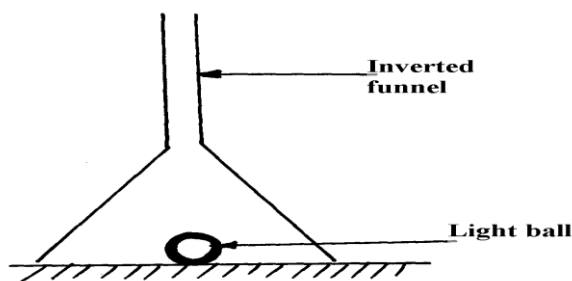

Explain the observation that would be made when streamlines of air is blown strongly down the narrow section of the funnel

18. A block measuring $20\text{cm} \times 10\text{cm} \times 5\text{cm}$ rests on a flat surface. The block has a weight of 3N . Determine the maximum pressure it exerts on the surface.
19. The figure below shows a hydraulic press **P** which is used to raise a load of 10KN . A force **F** of 25N is applied at the end of a lever pivoted at **O** to raise the load

- (a) State **one** property of liquid **X**
- (b) Determine the distance **x** indicated on the press if force on piston **B** is 100N
19. A mercury –in-glass barometer shows a height of 70cm. What height would be shown in the barometer at the same place if water density $1.0 \times 10^3 \text{kg/m}^3$ is used.
(Density of mercury = 13600kgm^{-3})
20. The total weight of a car with passengers is 25,000N. The area of contact of each of the four tyres with the ground is 0.025m^2 . Determine the minimum car tyre pressure
21. (a) The diagram below represents a u-shaped glass tube sealed at one end and containing mercury

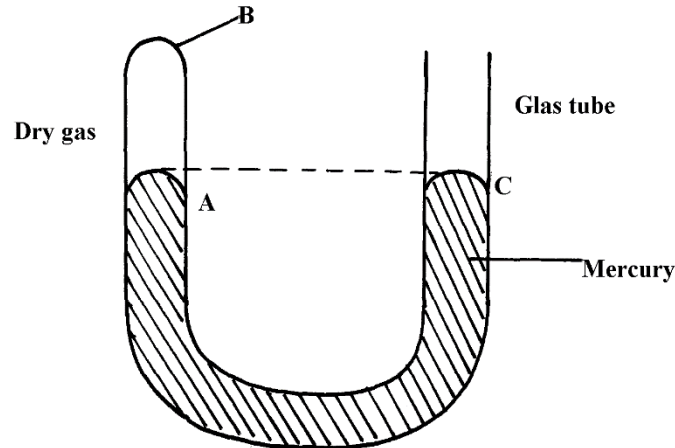

- (i) What is the pressure of the gas as shown in the diagram above?
- (ii) Explain why the gas should be dry if it is to be used to verify a gas law
- (iii) Describe how the arrangement can be used to verify Boyle's law.
- (b) Use the kinetic theory of gases to explain why;
- (i) the pressure of a gas increases with temperature increase
- (ii) The pressure of a gas decreases as volume increases
22. The reading on a mercury barometer at Mombasa is 760mm. Calculate the pressure at Mombasa (density mercury is $1.36 \times 10^4 \text{Kgm}^{-3}$)
23. The figure below is a manometer containing water. Air is blown across the mouth of one tube and the levels of the water changes as the figure below.
Explain why the level of water in the right limb of manometer is higher.

CURRENT I

1. (a) Distinguish between natural and forced convection currents
- (b) Draw the cross-section of a basic solar heating panel that uses heat from the sun to warm water which flows through pipes
- (b) Explain the following as regards to the solar heater:-
- (i) Why the pipe is made of copper
- (ii) How the green house effect occurs and aids the working of the panel
2. State **two** advantages of generating an alternating current (a.c) to direct current (d.c) in a power station.

3. The table below shows results obtained in an experiment to determine the internal resistance of a cell

V)						
R)	5	5	0	5	0	
(V^{-1})						
(R^{-1})						

- i. Complete the table for values of $1/V$ and $1/R$ giving your answers to 3 d.p
 - ii. Plot a graph of $1/V$ against $1/R$
- iii. Use the graph to determine the e.m.f E and the internal resistance r of the cell given that

$$\frac{E}{V} = \frac{r}{R} + 1$$

(4mks)

PARTICULATE NATURE OF MATTER

1.
 - (a) State the kinetic theory of matter
 - (b) State **two** reasons why gas particles diffuse faster than solid particles
 - (c) You are provided with a long glass-tube, fitting corks, cotton wool, concentrated solution hydrochloric acid and concentrated ammonia solution.
 - (i) Draw a possible set-up to compare the rates of diffusion of ammonia gas and hydrochloric acid gas
 - (ii) Outline a clear procedure on how the experiment can be carried out
 - (iii) What are the possible observations and conclusion
2. Distinguish between gases and liquids in terms of inter molecule forces.
3. What is the experimental evidence that shows that molecules in gases and liquids are in a state of motion
4. State Newton's second law of motion.
5. Smoke particles in air when strongly illuminated were observed to describe continuous, random haphazard movements. Explain what would be observed when the air temperature is decreased
6. State how heat transfer by radiation is reduced in a vacuum flask
7. (a) A partially filled balloon is placed in a bell jar with its open end on a thick glass plate as shown

in *figure 16*. The contact between the jar and the glass plate is greased to make it air tight:

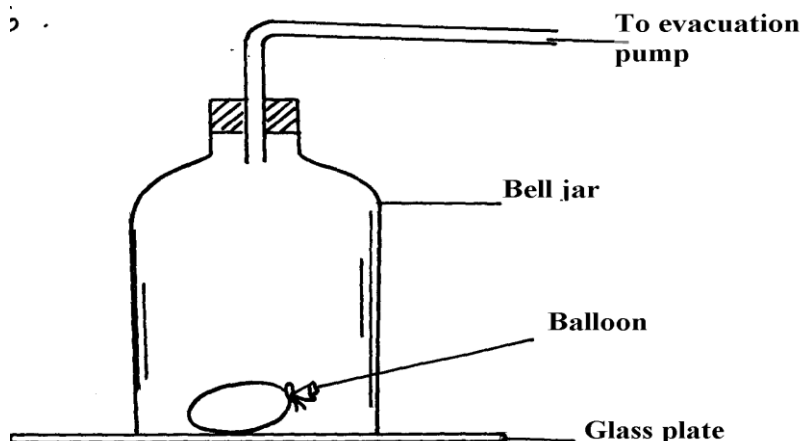

State and explain what happens to the balloon when air in the ball jar is slowly evacuated

(b) **Figure 17** below shows an arrangement to demonstrate diffusion through solids:-

fig. 17

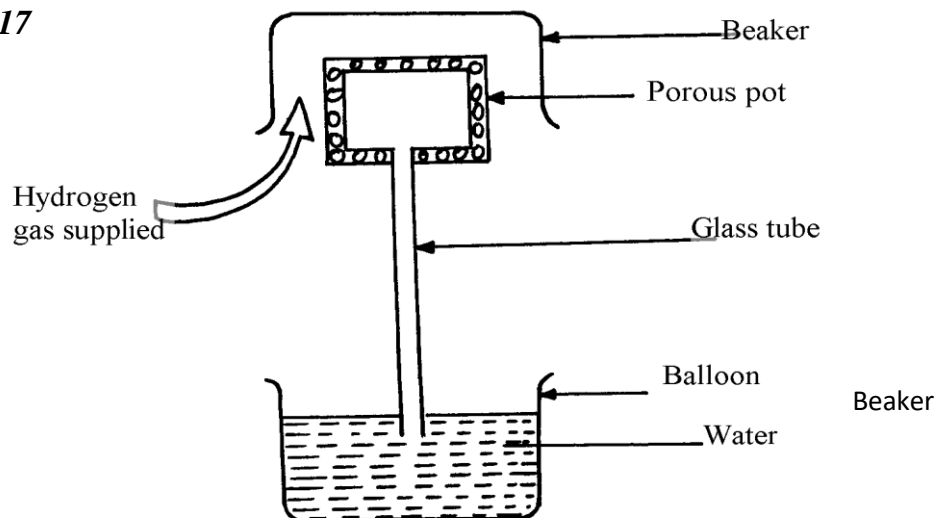

The hydrogen gas is supplied for sometimes then stopped. State and explain what is likely to be observed when the hydrogen gas supply:-

- (i) is on
- (ii) is stopped

(c) The diagram fig. 18 shows a glass tube containing enclosed air by a thread of mercury 50mm long when the tube is held in a horizontal position

fig. 18

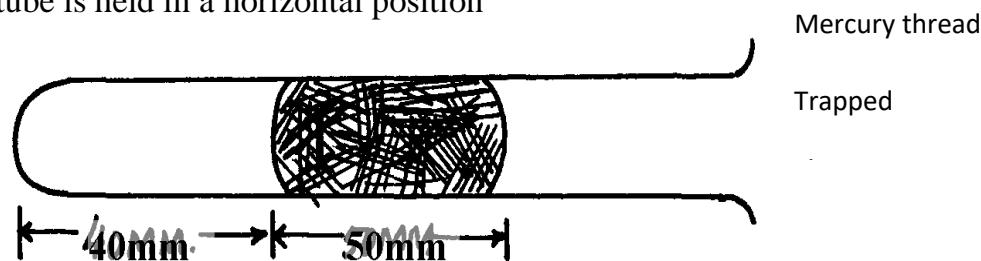

- (i) The tube is slowly raised in a vertical position with the open end facing up. Determine the new length of the trapped air (tube has same area of cross-section; atmospheric pressure = 750mmHg)
- (ii) Account for the difference in the column of trapped air using kinetic theory of matter assuming that temperature is constant.

8. Two samples of bromine vapour are allowed to diffuse separately under different conditions, one in a vacuum and the other in air. State with reasons the conditions in which bromine will diffuse faster
9. In terms of kinetic theory of matter, explain why evaporation causes cooling
10. (a) In an experiment to demonstrate Brownian motion, smoke was placed in air cell and observed under a microscope. Smoke particles were observed to move randomly in the cell.
 - (i) Explain the observation
 - (ii) Give a reason for using small particles such as those of smoke in this experiment
 - (iii) What would be the most likely observation if the temperature in the smoke cell was raised?

- (b) An oil drop of average diameter 0.7mm spreads out into a circular patch of diameter 75cm on the surface of water in a trough
- (i) Calculate the average thickness of a molecule of oil
 - (ii) State **two** assumptions made in (i) above

11. Give a reason why gases are more compressible than liquids
12. Explain the cause of random motion of smoke particles as observed in Brownian motion experiment using a smoke cell.

THERMAL EXPANSION

1. Figure 1 shows a beam balance made out of concrete and reinforced with steel
Use a diagram to explain the behaviour of the shape of the beam when heated up
2. (a) State **two** liquids which are used in thermometer.
- (b) With a reason, state which of the two liquids in 3 (a) above is used to measure temperature in areas where temperatures are:
- (i) below -40°C
 - (ii) 150°C
3. What do you understand by the statement '**lower fixed point**' on a temperature scale?
4. Name **two** adaptations that can be made to a mercury thermometer to make it more sensitive
5. **Figure 5** shows a bimetallic strip made of brass and iron. A marble is placed at end **A** of the bimetallic strip as shown below:-

fig. 5

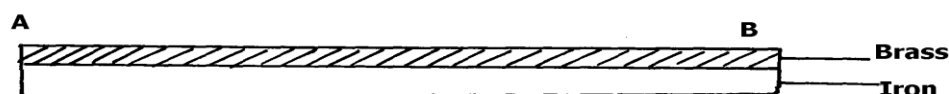

State and explain what will be observed when the bimetallic strip is strongly cooled

6. The figure below represents a bimetallic strip of metals **X** and **Y** at room temperature

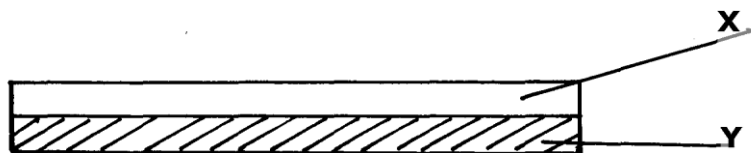

The figure below shows its shape when dipped into crushed ice



Sketch a diagram in the space given below to show the shape when the strip is heated to a temperature above the room temperature

7. Give a reason why a concrete beam reinforced with steel does not crack when subjected to Changes in temperature.

RECTILINEAR PROPAGATION AND REFLECTION OF LIGHT

1. State the property of light associated with formation of shadows.

(1mk)

2. The diagram shows a lamp and a piece of cardboard. The piece of cardboard has a hole in it. Light from the lamp passes through the hole and forms a bright spot on a wall.

piece of
cardboard

A
B
C

wall

hole



lamp E

D

- (a) (i) Which point on the wall, A B, C, D or E, is lit up by the lamp?

1 mark

- (ii) Explain why the **other** points on the wall are **not** lit up by the lamp.

1 mark

- (b) A piece of clear green plastic is placed over the hole.
What is the colour of the light which shines on the wall?

1 mark

- (c) The diagram shows a ray of light from a lamp hitting a mirror.

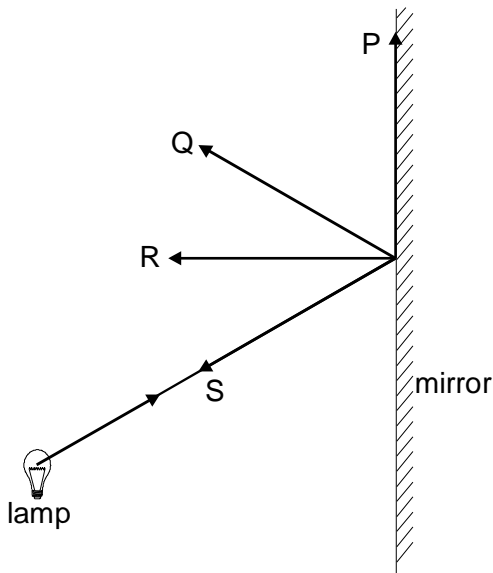

Which arrow, P, Q, R or S, shows the reflected ray?

1 mark

Maximum 4 marks

3. (a) The diagram shows a motorist looking into her driving mirror.

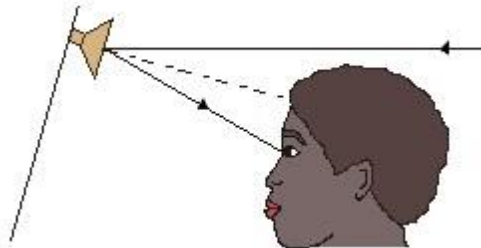

(i) Mark on the diagram: the letter 'I' to show the incident ray and the letter 'r' to show the angle of reflection.

(2 marks)

(ii) Name the dashed line shown in the diagram.

(1 mark)

4. The diagram below shows an object X placed in front of a plane mirror. A ray of light is drawn coming from the object X and striking the mirror at Y. After striking the mirror the ray of light is reflected.

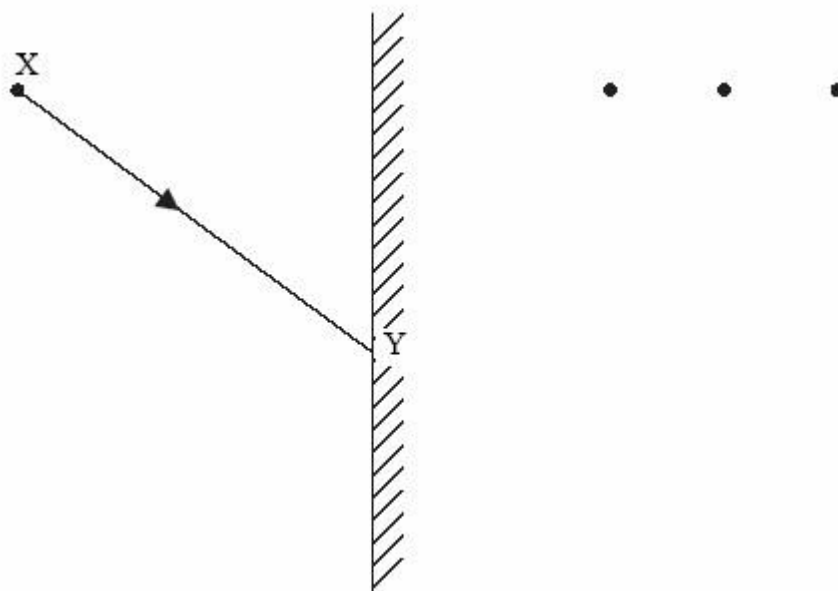

(a) (i) Which of the three dots represents the correct position of the image of X? Label this dot Z.

(1)

(ii) Draw a line to represent the reflected ray at Y. (2)

(b) Mark on the diagram, for the ray XY at the mirror,

(i) The angle of incidence and label it i ; (1)

(ii) The angle of reflection and label it r . (1)

(c) Is the image at Z real or virtual?

This is a Property of Mwalimu Consultancy Ltd. Contact Mr Isaboke

0746-222-000 for more Educational Materials.

5. James shone a ray of light at a mirror as shown below.

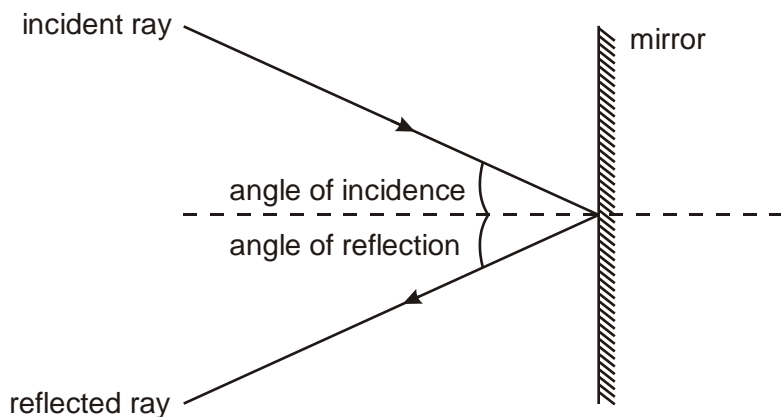

diagram 1

He measured the angle of **reflection** for different angles of incidence. His results are shown below.

angle of incidence (°)	30	40	50	60	70
angle of reflection (°)	30	40	50	65	70

(a) Which angle of reflection was **not** measured accurately?

.....°

How can you tell this from the table?

.....

1 mark

(b) James set up a different experiment as shown below.

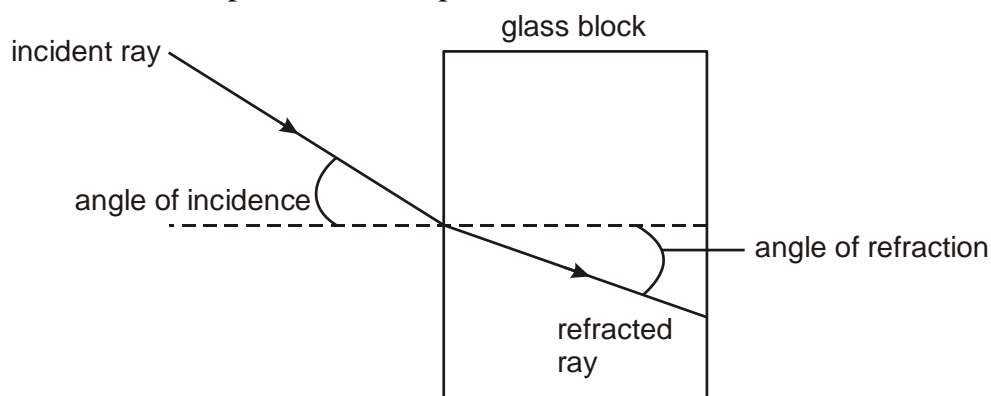
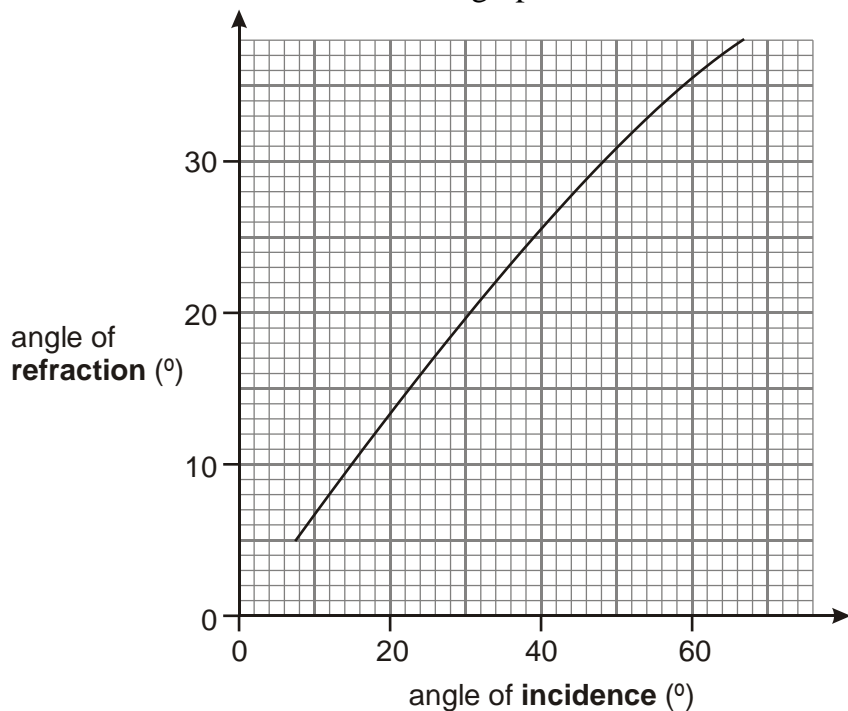

diagram 2

He measured the angle of **refraction** for different angles of incidence.

His results are shown in the graph.



Use the graph to answer the questions below.

(i) When the angle of **refraction** is 20° , what is the angle of **incidence**?

..... $^\circ$

1 mark

(ii) What conclusion could James draw from his graph? Complete the sentence below.

When light passes from air into glass, the angle of **incidence** is always the angle of **refraction**.

1 mark

(c) **On diagram 2**, draw a line to continue the refracted ray as it leaves the glass block.

1 mark

maximum 4 marks

6. The diagram shows a plane mirror used by a dentist to see the back of a patient's tooth.

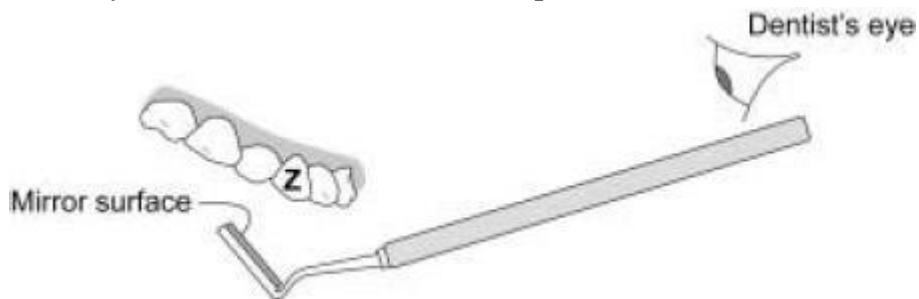

(a) Use a ruler to draw a ray of light on the diagram to show how the dentist is able to see the tooth labelled **Z**.

(3)

(b) Describe the image formed by a plane mirror.

(2)

(Total 5 marks)

It is night-time and the desk lamp is on. Light shines onto the key.

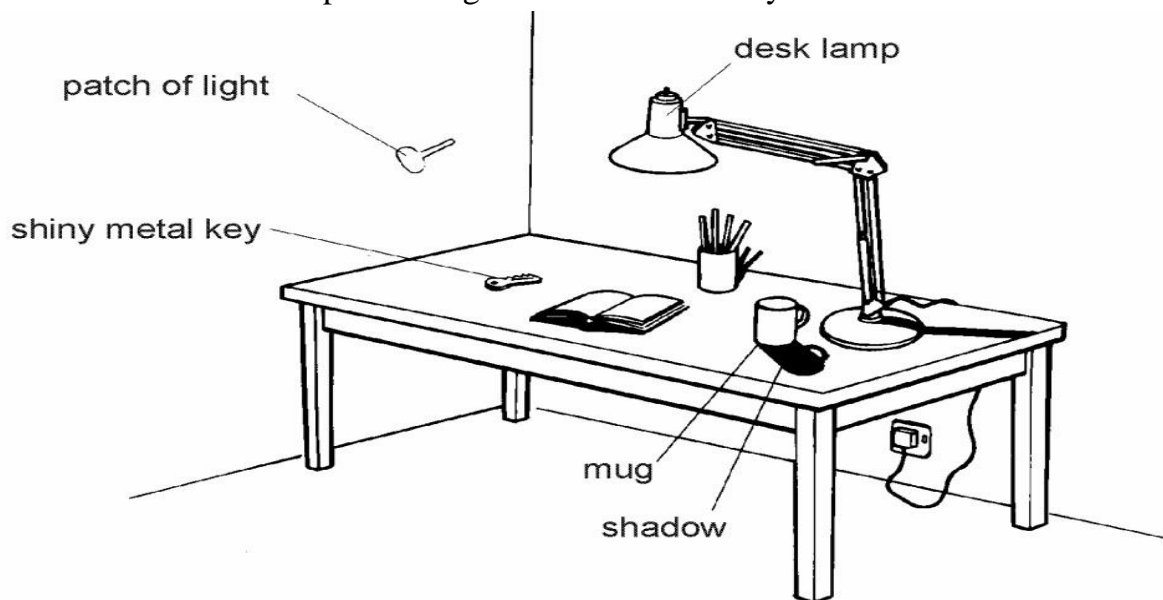

- (c) (i) Draw **one** ray of light on the diagram to show the light shining from the lamp onto the key. Use a ruler.
- Put an arrow on the ray to show the direction of the light. 2 marks
- (ii) There is a patch of light on the wall. This light has been reflected from the key. Draw a reflected ray of light on the diagram. Use a ruler. 1 mark
- (d) There is a dark shadow on the table beside the mug. Explain how this shadow is formed.

HEAT TRANSFER

1. A glass beaker contains water. When the centre of the base of the beaker is heated, a convection current is set up.

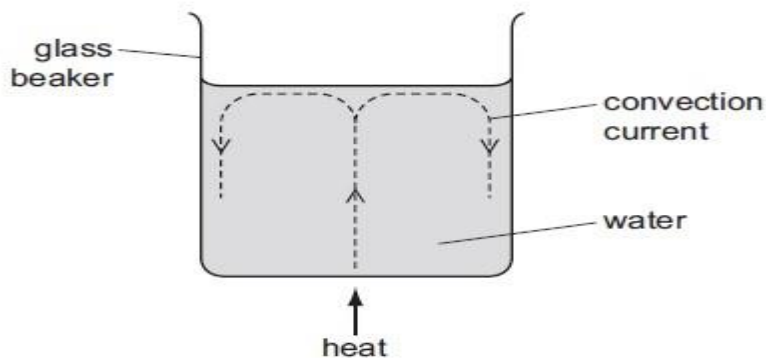

Which statement explains this?

- A. The evaporation of water causes water molecules to rise to the surface.
- B. The expansion of water molecules causes them to rise to the surface.
- C. The water above the heat source rises because it becomes less dense.
- D. The water at the sides sinks because it becomes less dense.

2. Two identical copper cans are filled with boiling water.

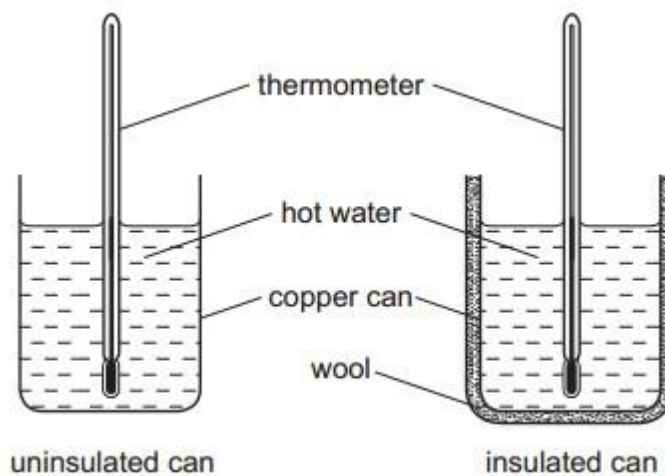

One can is insulated with wool. The temperature of the water in each can is taken every minute for several minutes. Graphs of the results are plotted.

Which graph shows the results obtained?

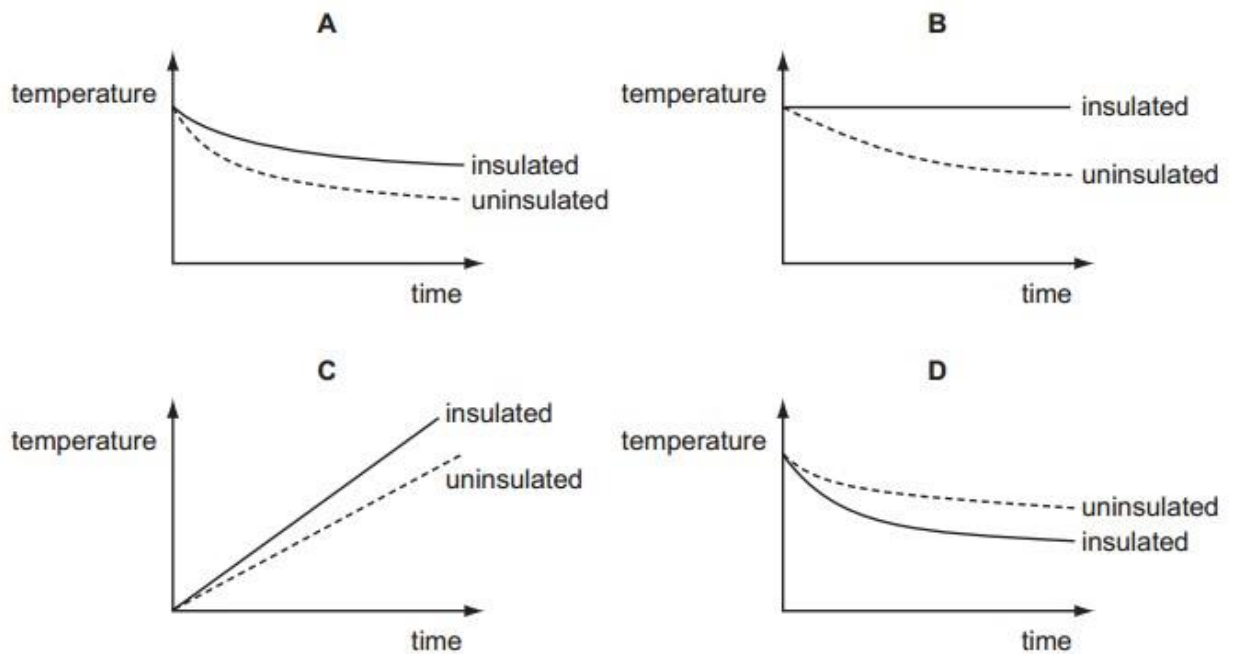

3. In a vacuum flask, which methods of heat transfer are prevented by the vacuum?
- A conduction only
 B convection only
 C conduction and convection only
 D conduction, convection, and radiation
4. The diagram shows a cooling unit in a refrigerator.

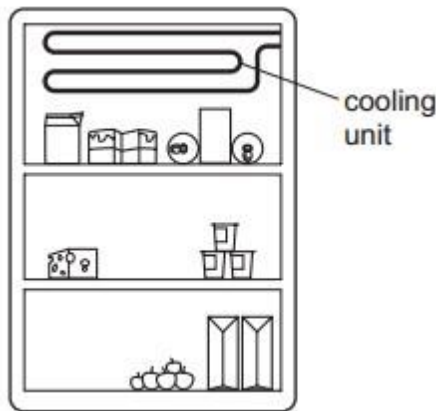

Why is the cooling unit placed at the top?

- A Cold air falls and warm air is displaced upwards.
 B Cold air is a bad conductor so heat is not conducted into the refrigerator.
 C Cold air is a good conductor so heat is conducted out of the refrigerator.
 D Cold air remains at the top and so prevents convection.
5. Two metal teapots are identical except that one is black on the outside and the other is white on the outside, as shown below.

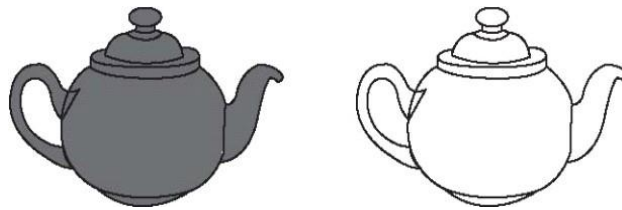

The teapots each contain the same amount of hot water.

State and explain which teapot will cool down more quickly. [3] [Total3m]

6. Logs of wood are burning in a camp-fire on the ground. A person is sitting nearby.



- (a) (i) State two types of energy that the burning logs possess.

- (ii) State the main method of heat transfer by which energy from the fire reaches the person sitting nearby.

[3] (b) A spark jumps out of the fire.

- (i) State the name of the type of energy that the spark possesses due to its movement.
(ii) The spark lands on the person's hand.

State which method of heat transfer causes the person to feel the spark.

- (iii) The pain caused by the spark makes the person stand up.

1. State the type of energy that has increased, now that he is standing.
2. State the type of energy stored in his body that enabled him to stand.

[4]

7. The main parts of a cold store are shown in Fig. 4.1.

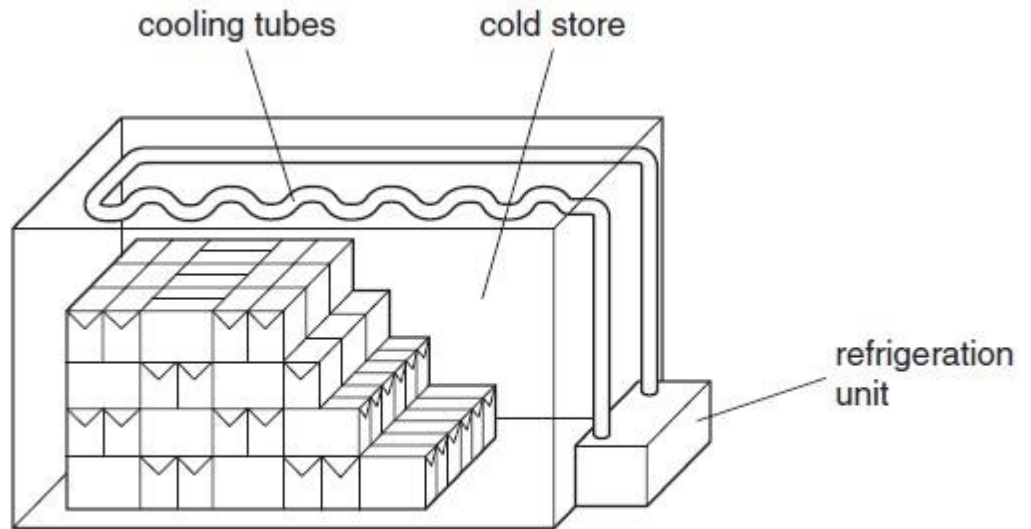

Fig. 4.1

- (a) Explain why the cooling tubes are positioned at the top of the store.
- (b) Suggest why the refrigeration unit is outside the cold store.
- (c) The walls are made of thick thermally-insulating material. Why is it important to have the walls made like this?

Even when the refrigeration unit is running continuously, there comes a time when the temperature in the store stops falling, and remains constant. Explain why this happens.

Fig. 7.1 shows a refrigerator in which a liquid absorbs thermal energy from the cold compartment and evaporates. As the vapour is compressed by the pump, work is done on it. The vapor condenses, giving out thermal energy to the surroundings through the cooling fins on the back of the refrigerator.

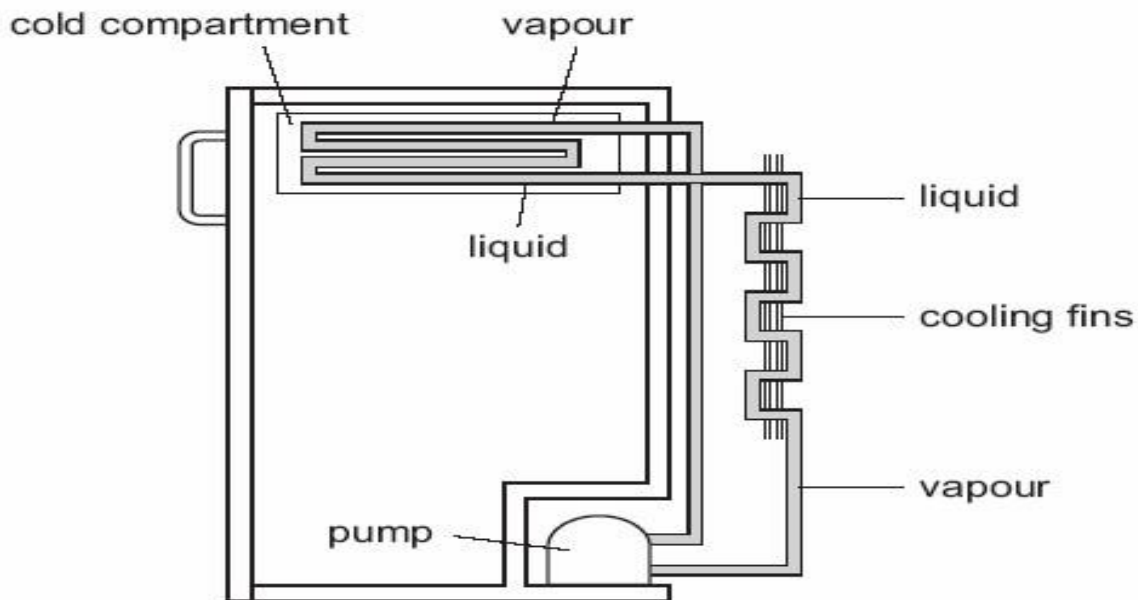

Fig. 7.1

(a) Explain the difference between boiling and evaporation.

Explain why the pump compresses the vapour much more than it could compress a liquid.

Explain the effect that a refrigerator has on the temperature of the air surrounding it.

The pump is rated at 220 V, 110W.

(i) Calculate the working current of the pump.

Show your working.

Calculate the working resistance of the pump.

9. Three horizontal rods are placed with one end just above a Bunsen flame. The other end of each rod is coated with wax, as shown in Fig. 3.1.

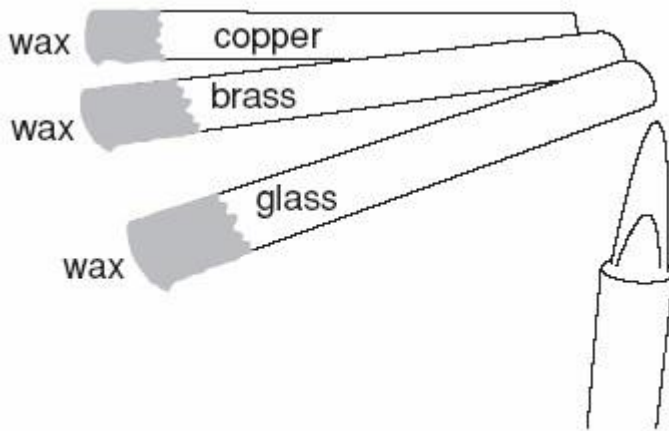

Fig. 3.1

Describe how you would use the apparatus to discover which rod is the best conductor of heat.

FOR MARKING SCHEMES

CONTACT MR ISABOKE

0746222000

CALL/TEXT 0746 222 000

mwalimuconsultancy@gmail.com

**THIS IS A PROPERTY OF MWALIMU
CONSULTANCY LTD.**

**POWERED BY MR
ISABOKE**

SUCCESS